

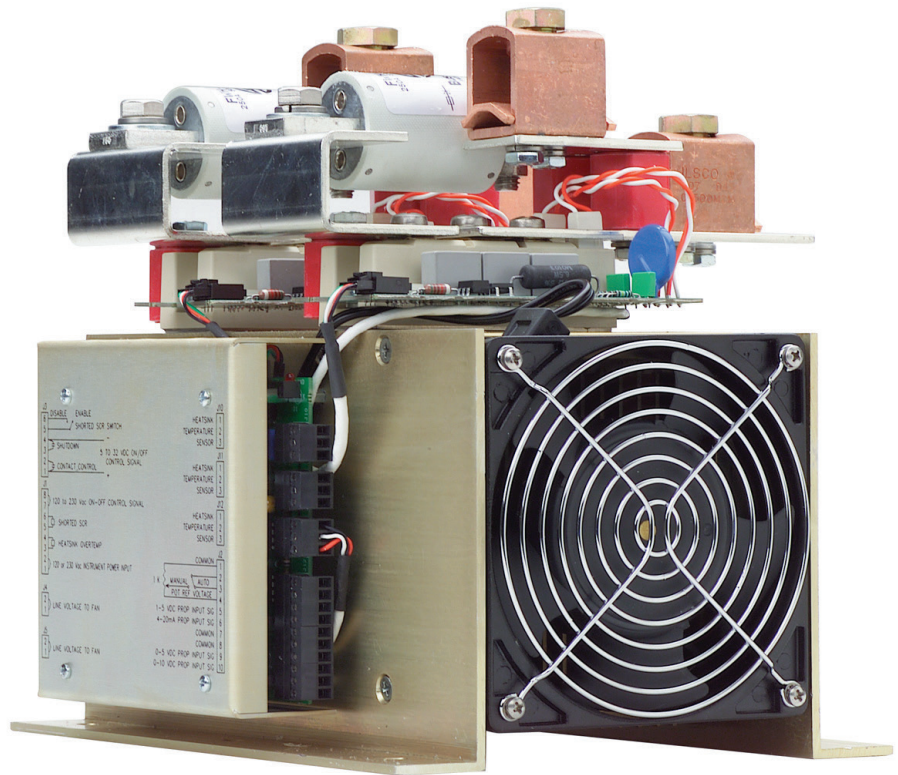

# MaxPac Digital



## 4.2.6 - Command Signal Wiring

	 <b>WARNING</b>
<p><b>The following wiring instructions are for the Digital MaxPac only. If using Analog MaxPac, contact factory for appropriate wiring schematics. Analog MaxPacs are designated as MXPCI,II, or III followed by the number 1, 2, 3, or 4 under the firing mode.</b></p>	

Please refer to the following figure for illustrations of the 6-, 8-, and 10-pin input terminals.

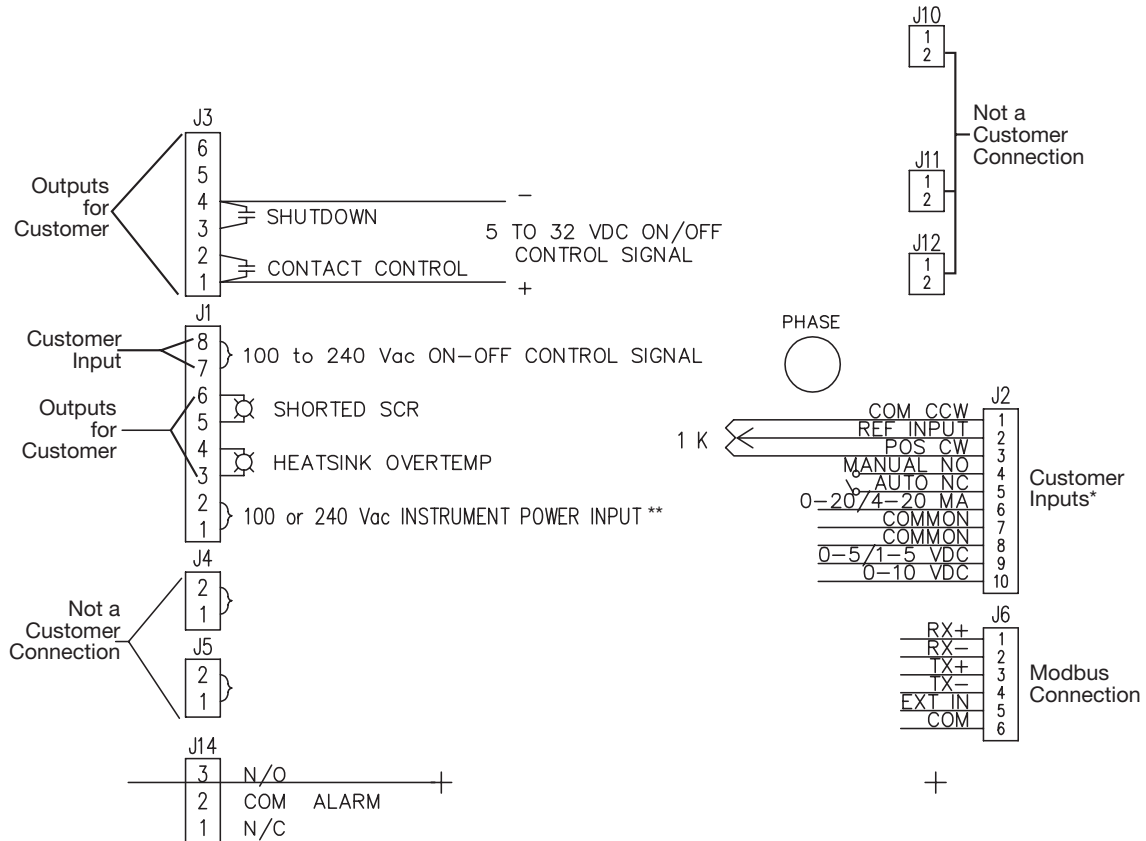

\*Only one customer input is allowed, eg. J3 pins 1 & 2 contact control may not be used at the same time as J2 pins 6 & 7 (4-20 mA)

\*\*Instrument power 4 VA maximum

### MaxPac I, II, and III

#### On/Off Control Signals

**AC Input** – The 120 – 230 VAC signal lines are connected to terminal J1-7 & 8. An input voltage of 120 to 230 VAC turns the power On. The turn OFF voltage for the power control is 0 VAC.

**DC Input** – The 5 – 32 VDC signal lines are connected to terminal J3-1&4. An input voltage of 5 to 32 VDC turns the power On. The turn OFF voltage for the power control is 0 VDC.

**NOTE:** For AC or DC input to be used for ON/OFF control, SW1 rotary switch must be set to position 0 and unit must be jumpered for AUTO

**Contact Closure Input** – The dry contact signal lines are connected to terminal J3-1&2. A closed contact turns the power On. The turn OFF is an open contact.

### Process Analog Control Signals

The MaxPac II accepts 0 – 5/1 – 5/0 – 10 VDC and 4 – 20 mA input signals, they are factory calibrated. The following signals are connected to:

- 0 - 5 VDC: Terminal J2 - 9(+) & 7(-)
- 1 - 5 VDC, 11 - 5 VDC: Terminal J2 - 5(+) & 7(-)
- 0 - 10 VDC: Terminal J2 - 10(+) & 7(-)
- 4 - 20 mA, 10 - 20 mA: Terminal J2 - 6(+) & 7(-)

### Auto/Manual Input

The MaxPac I, II and II can be wired to make it possible to select an input from either a temperature/process controller or a manual input potentiometer. A switch is used to select between the input from a 1K potentiometer or a linear control input (see input connections).

The unit is shipped with a jumper from terminals 4 and 5 of terminal block J2. This jumper must be removed when connecting the auto/manual switch and potentiometer.

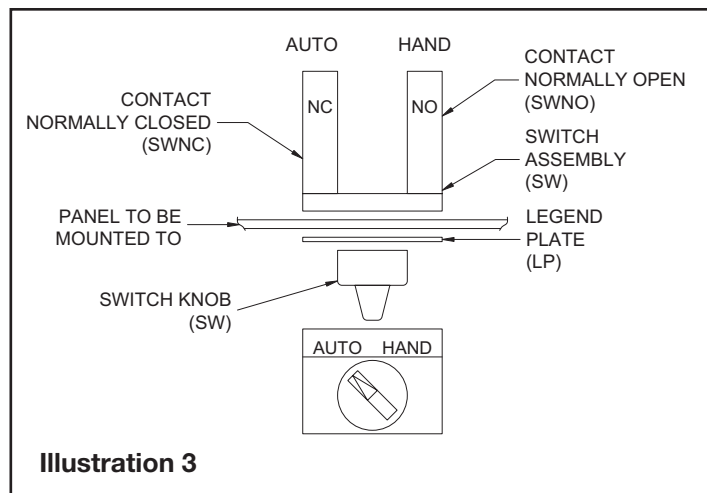

### Demand Indicator

The LED demand indicator is located on the main PC board and is viewable through the cover. With the On/Off control option, the indicator will display steady “on” and steady “off”. With the DOT Firing or Time-Proportional options, the indicator will display the firing sequence.

### SCR Control Board

The control board provides the following functions:

The low voltage dc to operate the circuitry:

A switching regulator circuit converts the instrument power to +8 VDC.

The power distribution for the cooling fans:

The incoming instrument power is routed to the fan power terminals.

Add fusing as required for fan power requirement.

The signal condition for the on/off input and analog inputs:

The 120 to 240 on/off input is isolated by an opto-coupler. The DC and contact closure inputs are buffered by the circuitry.

The drive signal to the SCR trigger boards:

The temperature alarm:

The heat sink temperature is derived from a resistive temperature detection (RTD) sensor mounted on the heat sink. This is then compared to two set points.

The first alarm is a warning and activates the externally connected device.

This allows time to correct the problem before the second alarm inhibits the firing circuit.

The Shorted SCR Alarm:

When a short is detected the externally connected device output is activated.

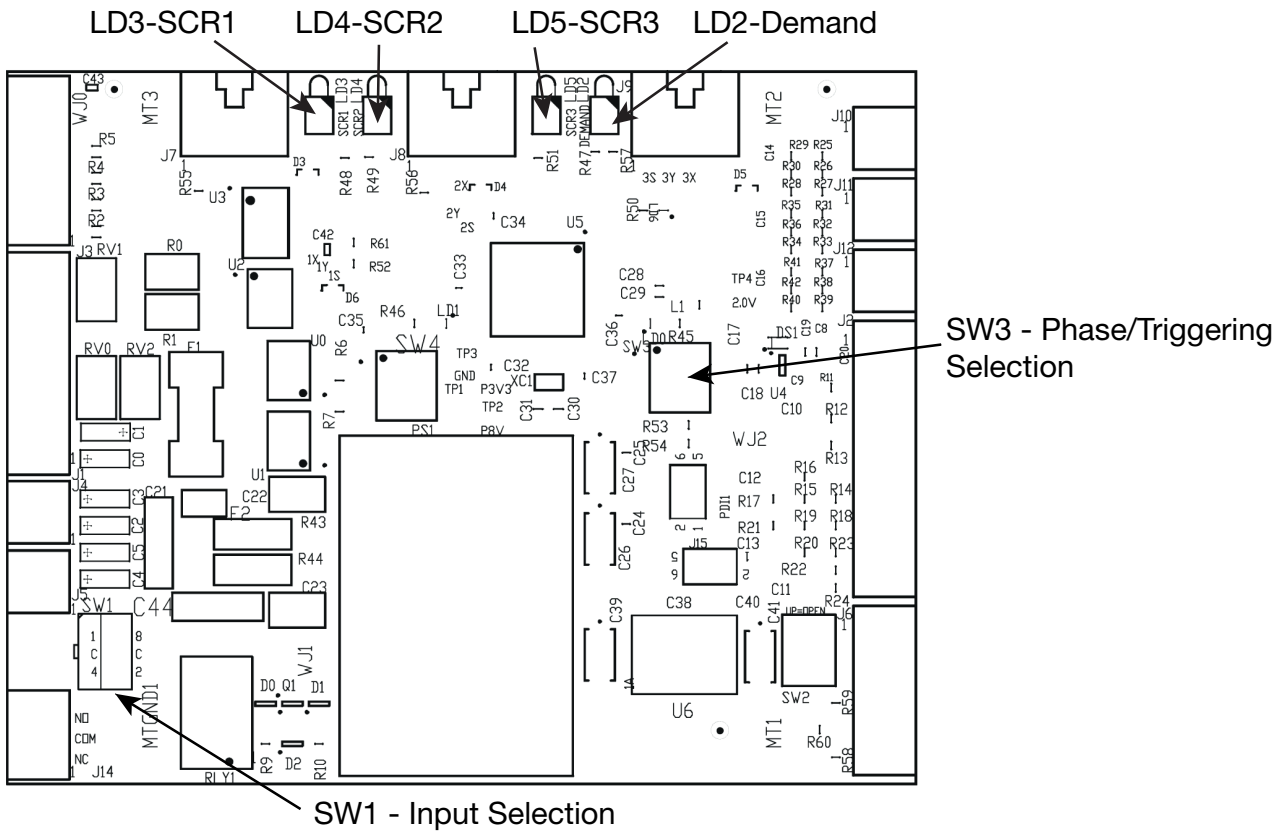

The method of setting the MaxPac for desired mode of operation is as follows:

#### Input Command Selection

The unit can be set to drive its output in response to the following command inputs:

- Analog potentiometer
- Analog inputs: 4-20mA (or 0-20mA), 0-5Vdc (or 1-5Vdc), 0-10V
- Digital ON/OFF inputs: AC ON/OFF, DC ON/OFF

To select between any of these inputs, set the MaxPac as indicated in the table below:

Input Command Select	Method of Selection
Potentiometer	Select MANUAL mode by leaving no connection between J2.4 & J2.5. The rotary switch selection at SW1 is ignored when in MANUAL mode  OR  Select AUTO mode by jumpering J2.4 & J2.5, and then set rotary switch at SW1 to position 1
ON / OFF (will turn output in if either AC or DC ON/OFF inputs are energized)	Select AUTO mode by jumpering J2.4 & J2.5, and then set rotary switch at SW1 to position 0
0-10Vdc	Select AUTO mode by jumpering J2.4 & J2.5, and then set rotary switch at SW1 to position 2
0-5Vdc	Select AUTO mode by jumpering J2.4 & J2.5, and then set rotary switch at SW1 to position 3
1-5Vdc	Select AUTO mode by jumpering J2.4 & J2.5, and then set rotary switch at SW1 to position 4
0-20mA	Select AUTO mode by jumpering J2.4 & J2.5, and then set rotary switch at SW1 to position 5
4-20mA	Select AUTO mode by jumpering J2.4 & J2.5, and then set rotary switch at SW1 to position 6
<b>Note:</b> SW1 position 7 is reserved for factory use, and should not be used	

### Phase Selection and Firing Mode

SW3 selects the phase selection and firing method of the MaxPac.



Normally, this switch should be left in its factory-installed position. If it should become necessary to change it, set only accordance to the table below. Choosing a setting that does not match your unit's number of phases and legs will result in the unit entering alarm mode and turning the output off after an initial attempt to turn outputs on.

SW3 Position	Selection	Note
0	Reserved for factory use	Do Not Use this Selection
1	DOT for MXPCI	Caution: Do not choose this setting if your unit is a MXPCII or MXPCIII type
2	DOT for MXPCII	Caution: Do not choose this setting if your unit is a MXPCI or MXPCII type
3	DOT for MXPCIII	Caution: Do not choose this setting if your unit is a MXPCI or MXPCII type
4	Time Proportional for MXPCI	Caution: Do not choose this setting if your unit is a MXPCII or MXPCIII type
5	Time Proportional for MXPCII	Caution: Do not choose this setting if your unit is a MXPCI or MXPCII type
6	Time Proportional for MXPCIII	Caution: Do not choose this setting if your unit is a MXPCI or MXPCII type
7	Reserved for factory use	Do Not Use this Selection

## LED Indicators

LEDs and their function are as follows:

Designator	Name	Description
LD2	Output Demand Indication	This LED blinks on according to the switching of output
LD3	Switch SCR1	OFF in normal operation. Turns ON if shorted SCR is detected in one direction. Blinks rapidly if phase voltage is not present or if SCR is shorted in both directions.
LD4	Switch SCR2	OFF in normal operation. Turns ON if shorted SCR is detected in one direction. Blinks rapidly if phase voltage is not present or if SCR is shorted in both directions.
LD5	Switch SCR3	OFF in normal operation. Turns ON if shorted SCR is detected in one direction. Blinks rapidly if phase voltage is not present or if SCR is shorted in both directions.

## Alarm Output

The form C contact at J14 will be in the alarmed state in any of the following conditions:

- If any shorted SCR is detected. One or more of the shorted SCR LEDs LD3-LD5 will be lit in this case
- If missing Zero Cross transitions are detected at the SCRs. Typically, this is caused by missing power on one or more phases, or from incorrect detection of phase sequence. One or more of the shorted SCR LEDs LD3-LD5 will be blinking in this case
- If sensed temperature of the heat sink at an SCR junction exceeds 200 degrees Fahrenheit or 93 degrees Celsius. The Overtemp output will also be engaged in this case.
- If sensed phase sequence does not match the setting of selector SW3. (Normally, SW3 should be left in its factory-set state. See caution in section titled, "Phase Selection and Firing Mode").

## Remote Stop

When it is necessary to disable or enable the output, connect a dry contact between J3 – 3 & 4. When it is closed, the power control will disable the output.

<b>CAUTION</b>
<b>IMPORTANT:</b> This stop overrides the control input only. It will NOT protect against faulted or damaged SCRs.

## Shorted SCR Detection (optional)

This feature provides a means of alerting an operator to a problem with the system. An external indicated lamp or relay can be connected to J1 – 5 & 6 (See Fig. 2). This indicator must be rated for the instrument power applied to J1 -1 & 2. Three diagnostic LEDs show which SCR pair is faulted. These lights are synchronized with the demand indicator and can only indicate while the demand is active.

The MaxPac includes built in filtering to avoid false shorted SCR alarms, with parameters adjustable through ModBus communications.

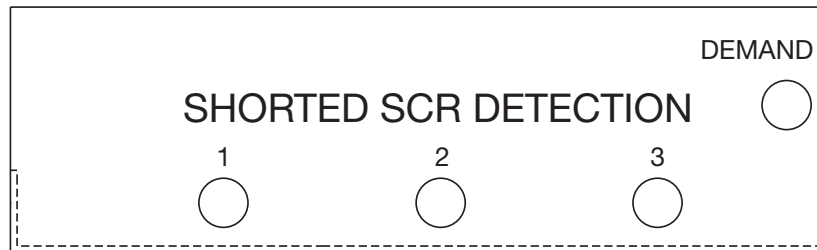

## Heat Sink Over-Temperature

An external lamp or relay may be connected to J1 – 3 & 4 (see Figure 2) (this must be rated for the instrument power applied to J1 – 1 & 2). This will provide an indication to the operator that the heat sink has approached an unsafe temperature level of 200°F (93°C). The unit will enter a stop mode if the temperature rises to 212°F (100°C).

**Input Terminals (MaxPac I, II, and III):**

**FIG 1**

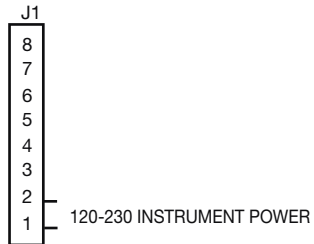

**120-230 INSTRUMENT POWER  
REQUIRED ON ALL CONFIGURATIONS**

**FIG 2**

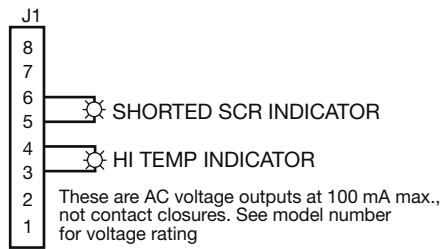

**SHORTED SCR AND  
HI TEMP INDICATORS.**

**FIG 3**

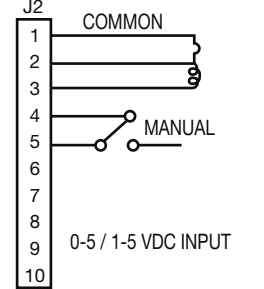

**MANUAL CONTROL INPUT SIG**

**FIG 4**

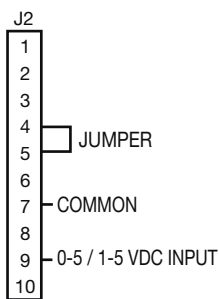

**0-5 / 1-5 VDC PROPORTIONAL INPUT SIG**

**FIG 5**

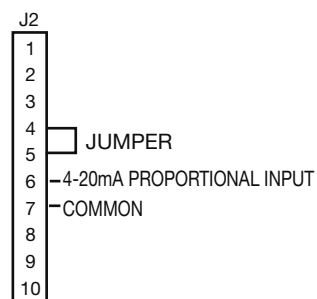

**4-20mA PROPORTIONAL INPUT SIG**

**FIG 6**

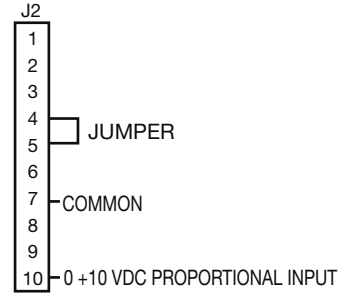

**0 +10 VDC PROPORTIONAL INPUT SIG**

**FIG 7**

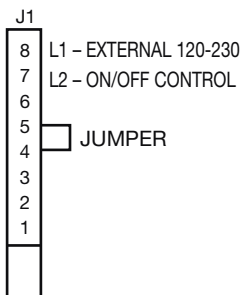

**120-240 ON/OFF CONTROL**

**FIG 8**

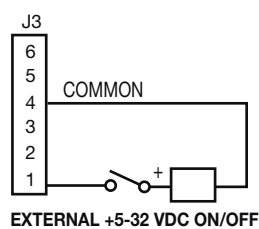

**EXTERNAL +5-32 VDC ON/OFF**

**FIG 9**

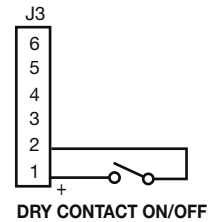

**DRY CONTACT ON/OFF**

**FIG 10**

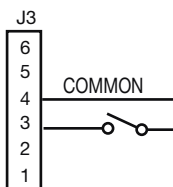

**REMOTE SHUTDOWN**



## MaxPac IP

The Chromalox MaxPac IP is a solid-state proportional power controller that utilizes a Phase Angle firing technique to modulate power to an inductive or resistive load. Separate adjustable Zero, Gain, Manual Bias, and Current Limit potentiometers are provided along with screw type plug-in connectors for input signals, Emergency Stop, and optional Remote Manual Bias with 0 - 100% dial. All units have thermostat protection with N.C. contacts.

### Start-up

The MaxPac IP has been factory calibrated for 4 - 20mA input. Be sure the operating voltage and signal input are correctly applied. Also, make sure the Emergency Stop, if used, has N.O. contacts and jumper pins 4 & 5 on the 10-pin connector if remote manual bias are not used. Please read the information on calibration at the end of this section for current limit settings for loads with extreme hot to cold ratios or those that are overrated. Other ranges may be field calibrated by use of zero and gain potentiometers.

### ⚠ CAUTION

**IMPORTANT:** With the Current Limit option, the current transformer must be terminated properly to prevent it from being damaged.

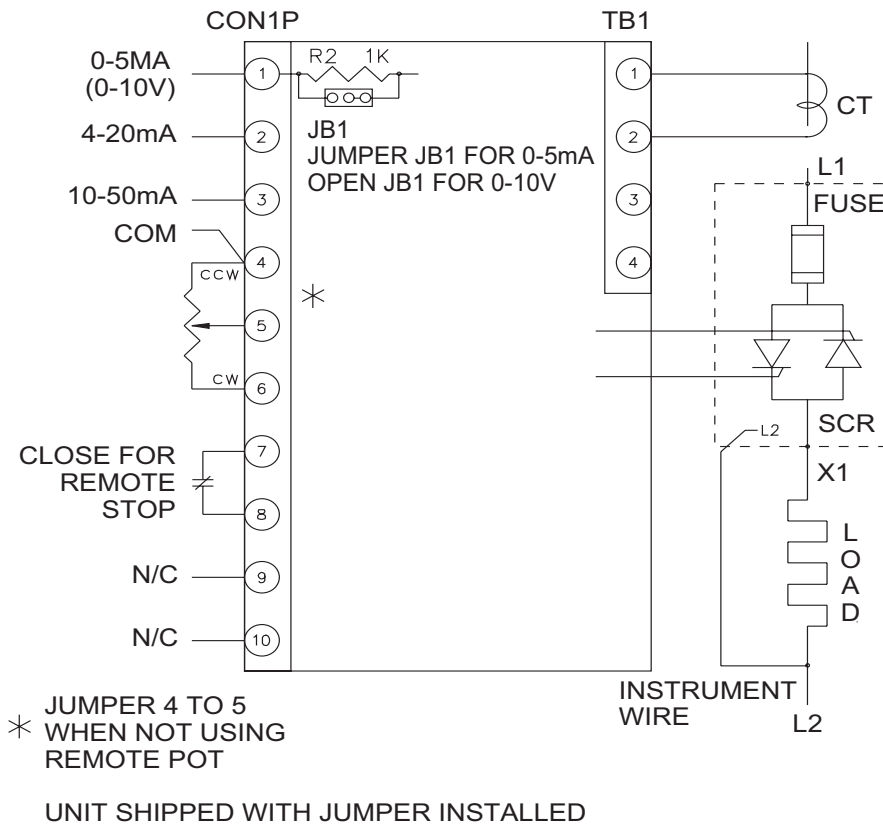

### Customer Connection

#### 4.2.6 - Calibration (MaxPac IP):

Many high-temperature heating elements exhibit extreme hot to cold resistance ratios. Heating elements composed of Platinum, Molybdenum, Tungsten, and Tantalum, to name a few, draw excessive current on start-up. Depending on the mass of the elements, these "high starting currents" may exist for extended periods of time. Generally, once the elements have achieved their normal operating temperatures, the current drawn through the MaxPac Power Pak will fall within the rating of the unit. For these types of loads, we recommend adjusting the I LIM (Current Limit) to 50% or less. This will decrease voltage as well as current.

1. Set Current Limit (I LIM) pot to 0% for full current output (CCW).  
Current Limit is for limiting current for loads that have extreme hot to cold resistance ratios or are overrated. We recommend for these types of loads to adjust I LIM (Current Limit) to 50% or less. This will also decrease voltage as well as current. 0% Current Limit gives 100% current output (CCW). 100% Current Limit gives 10% current output (CW).
2. Set Manual (MAN) pot to zero so unit will not be biased above input (CCW).  
Manual control adjustment provides a means of setting the output level of the MaxPac Power Pak in the absence of controlling instrumentation. The manual control signal value "adds" to the controlling instrument to set minimum output. The desired output power level may be set by adjusting the manual control. This value of output will then be present even in the absence of a control signal.
3. Set Remote Manual pot to zero output so unit will not be biased above input (CCW). (Jumper pins 4 & 5 if not used.)  
Remote Manual control adjustment provides a means of setting the output level of the MaxPac Power Pak in the absence of controlling instrumentation. The Remote Manual control is also effective when a control signal is connected. The Remote Manual control signal value "adds" to the controlling instrument to set minimum output. The desired output power level may be set by adjusting the Remote Manual control. This value of output will then be present even in the absence of a control signal. Connect Remote Manual pot wire to Pin 4 (CCW), Pin 5 (W), and Pin 6 (CW) of plug-in connector.
4. Check for open contact for Emergency Stop.  
Emergency Stop inhibits all SCR trigger pulses regardless of the level of the input signal or manual potentiometer. For Emergency Stop, close contact Pin 7 to Pin 8 of plug-in connector. Leave contacts open for operation.
5. Check for polarity of input signal.
6. Adjust input signal to low end of scale.  
Zero Adjust control sets the power output starting point or reference. Thus, it effectively cancels positive inputs to the MaxPac Power Pak.  
EXAMPLE: 0 - 5 mA input → set to 0 mA input  
4 - 20 mA input → set to 4 mA input
7. With power off, connect line voltage and load as shown.
8. Connect meter to input and output.  
**WARNING: Set meter to correct scale to read proper input or output.**
9. Apply power to unit.
10. Adjust input signal to low end of scale.
11. Using the Zero pot, adjust the output voltage just to zero volts.
12. Adjust input signal to top end of scale.  
Gain Adjust Control sets the maximum power output for maximum input signal.  
EXAMPLE: 0 - 5 mA input: set to 5 mA input  
4 - 20 mA input: set to 20 mA input
13. Using the Gain pot, adjust output voltage just to maximum volts.
14. Repeat steps 11, 12, 13, and 14 until no adjustment is necessary of Zero and Gain pots for proper output voltage indication. Voltage output should increase proportionally to the signal input applied.
15. Adjust input signal to low end of scale (zero voltage output).
16. With Manual pot at zero for zero voltage output, adjust (CW) to 100% for full voltage output. Voltage output should increase proportionally. Return to CCW position and output will decrease to zero output.
17. With Remote Manual at zero for zero voltage output, adjust (CW) to 100% for full voltage output. Voltage output should increase proportionally. Return to CCW position and output will decrease to zero output.
18. With Manual pot (CW) at 100% and I LIM (Current Limit) at 0%, adjust I LIM towards 100% noting that voltage output decreases with the adjustment of the Current Limit pot. Adjust Current Limit pot for your application, if needed.
19. Turn POWER OFF and remove meters. TEST COMPLETE.