



# ENAPART



93 S Railroad Avenue Unit C  
Bergenfield NJ 07621 USA  
[www.enapart.com](http://www.enapart.com)  
[sales@enapart.com](mailto:sales@enapart.com)



Via del Canneto 35,  
Borgosatollo, Brescia - Italia  
[www.enapart.it](http://www.enapart.it)  
[vendite@enapart.it](mailto:vendite@enapart.it)



Barbaros Mah. Ihlamur Bul. Aĝaoĝlu  
My Newwork No:3/15 Ataşehir / İstanbul  
[www.enapart.net](http://www.enapart.net)  
[satis@enapart.net](mailto:satis@enapart.net)



PRIVADA 10 B SUR #3908 COL.  
ANZUREZ, C.P. 72530, PUEBLA, PUE  
[www.enapart.com.mx](http://www.enapart.com.mx)  
[sales@enapart.com.mx](mailto:sales@enapart.com.mx)



Friedrich-Ebert-Anlage 36, 60325  
Frankfurt am Main, Germany  
[www.enapart.de](http://www.enapart.de)  
[anfrage@enapart.de](mailto:anfrage@enapart.de)



4 boulevard Carnot, 95400  
villiers-le-bel, Paris, France  
[www.enapart.fr](http://www.enapart.fr)  
[sales@enapart.fr](mailto:sales@enapart.fr)



65049, ОДЕСА, ВУЛИЦЯ ІВАНА  
ФРАНКА, БУДИНОК 55, ПОВЕРХ 3  
[www.enapart.com.ua](http://www.enapart.com.ua)  
[sales@enapart.com.ua](mailto:sales@enapart.com.ua)



MUNICIPIUL BUCUREȘTI, SECTOR 3,  
B-DUL BASARABIA, NR.250, CORP P+5  
[www.enapart.ro](http://www.enapart.ro)  
[sales@enapart.ro](mailto:sales@enapart.ro)



〒584-0023 大阪府富田林市若松町  
東2丁目2番16号  
[www.enapart.co.jp](http://www.enapart.co.jp)  
[sales@enapart.co.jp](mailto:sales@enapart.co.jp)



PLAZA NUESTRA SEÑORA DE LAS  
NIEVES 12 ,LOCAL ,50012,ZARAGOZA  
[www.enapart.es](http://www.enapart.es)  
[ventas@enapart.es](mailto:ventas@enapart.es)



Складова база „Онгъл“, Склад А2, п.к.  
4006, гр. Пловдив, България  
[www.enapart.bg](http://www.enapart.bg)  
[sales@enapart.bg](mailto:sales@enapart.bg)



3 Austin Mews, High Street, Hemel  
Hempstead, HP1 3AF , United Kingdom  
[www.enapart.co.uk](http://www.enapart.co.uk)  
[sales@enapart.co.uk](mailto:sales@enapart.co.uk)

# TABLE OF CONTENTS

2007

## SECTION 1: PNEUMATIC LINEAR ACTUATORS

LH	1.001
ZB	1.002
VE	1.011
LG 50	1.021
LO 40	1.025
MLS-10	1.030
ML 13	1.040
ML 26	1.041
ML 33	1.042
ML 50	1.043
LMP 60	1.045
LMP 60-A	1.046
NT 61	1.051
NT 120	1.052
HT 20,50	1.061
HT 50,100	1.062
SA	1.071
PICK AND PLACE (complete station)	1.072

## SECTION 2: ELECTRIC LINEAR ACTUATORS

LM 26-RW	2.013
LM 60-RW	2.021
LM 60-RWA	2.025
LK 100 RW	2.035
LK 100 RWA	2.038
LK 120 ZR	2.040
LK 160-ZR	2.091 / 2.092
RE 75	2.121

## SECTION 3: ROTARY ACTUATORS

MD 12	3.010
MD 12/180 H	3.011
MD 12 D/180 H	3.012
MD 12/90 V	3.013
MD 20/180	3.020
MD 20/360	3.021
MD 20/180 V	3.022
MD 32/180	3.031
MD 32/180 V	3.032
MD 51/180 B	3.041
MD 51D/180	3.042
ZY	3.051

ZD 12/180	3.061
ZD 20/360	3.071
WL	3.090

## SECTION 4: GRIPPERS

ZZ 12/25, USE WITH HOLLOW UNITS	4.001
MZ 12/25, USE WITH HOLLOW UNITS	4.001
ZB, MOUNTING FLANGE	4.002
KZ, ANGULAR	4.010
KZP, SEMI PARALLEL	4.011
KZ 180, 180° ANGULAR	4.012
KZL, PARALLEL	4.013
KZ3, THREE FINGER ANGULAR	4.014

## SECTION 5: ACCESSORIES

CUSHIONS	5.001 / 5.002
SUCTION CUPS	5.021
FLOW CONTROL VALVES	5.032
ALIGNMENT SLIDE, X-Y STAGE	5.052

## SECTION 6: STANDS, MODULAR MOUNTING BRACKETS AND ADAPTER PLATES

SE, SD	6.001-6.020
--------	-------------

## SECTION 7: HANDLING SYSTEMS AND SPRING FEEDER

AUTOMATED TRAY CHANGER	7.001
WM-01	7.002
FG-SPRING FEEDER	7.003
NC-SPRING WINDING MACHINE	7.005
LOAD STATION	7.006

## SECTION 8: STOP SCREWS, SENSORS, CABLES, AND HEIGHT GAUGES

\*SEE SECTION FOR CONTENTS

## SECTION 10: LINEAR TRANSFER SYSTEMS

MP BELT SYSTEM	10.001
INQUIRY SHEET	10.002
OVER / UNDER PALLET SYSTEM	10.020
LARGE PALLET SYSTEM GP	10.301

All components provide peak performance for millions of cycles, and once initial life-cycle has been achieved, components can be restored to original operating efficiency within minutes using our available seal kits and bearing kits.

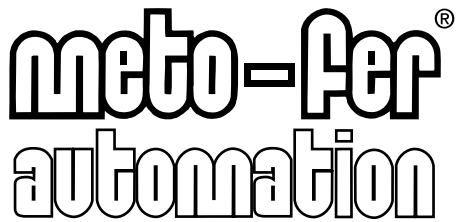
**mf automation, Inc.**

355 Wyoming Street

Pittsburgh, PA 15211

Phone: 412-488-3488; 1-888-METO-FER (1-888-638-6337)

Fax: 412-488-3498

E-mail: info@meto-fer.com

Web site: www.meto-fer.com

**About Meto-Fer Automation**

Meto-Fer Automation is your worldwide solution to industrial automation. Notable products include a full line of conveyor systems; linear belt pallet transfer systems (MP), and linear pallet over / under systems.

Our complete line of quality automation components includes linear slides with air cylinder, ball screws or timing belts, alignment slides, grippers, rotary actuators, elastomer - oil cushions, flow controls, height gauge controls, suction cups, mounting brackets, stands and adapter plates, precision stop system with sensing elements, electronic sensors, spring feeders, shaft hoppers, and modular pick and place units.

Meto-Fer products are engineered to provide long lasting trouble-free performance.

## Metric Conversions

TO CONVERT	TO	MULTIPLY BY
inches	mm	25.4
mm	Inches	.0394
lb	kg	.4535
kg	lb	2.2050
lb	N	4.4484
N	lb	.2248
psi	bar	.069
bar	psi	14.5
lb.in	Nm	.113
Nm	lb.in	8.85
lb.sq.ft	kgm2	.0421
kgm2	lb.sq.ft	23.73
scf	NL	28.361
NL	scf	.0353
hp	kW	.7457
kW	hp	1.341

# PNEUMATIC LINEAR ACTUATORS

SECTION 1

**meto-fer®**  
**automation**

Your complete source for industrial automation and electronics

**mf automation, inc.**

[www.meto-fer.com](http://www.meto-fer.com)

1-888-638-6337

# Linear units LH

- Progressive working oil cushions, includes oil reservoir KOB 50 (see sheet 6.001)
- Patented stop screws with sensing device
- High repeat accuracy
- Many combination possibilities
- Third position stop dowel pin for use with vertical unit VE \*

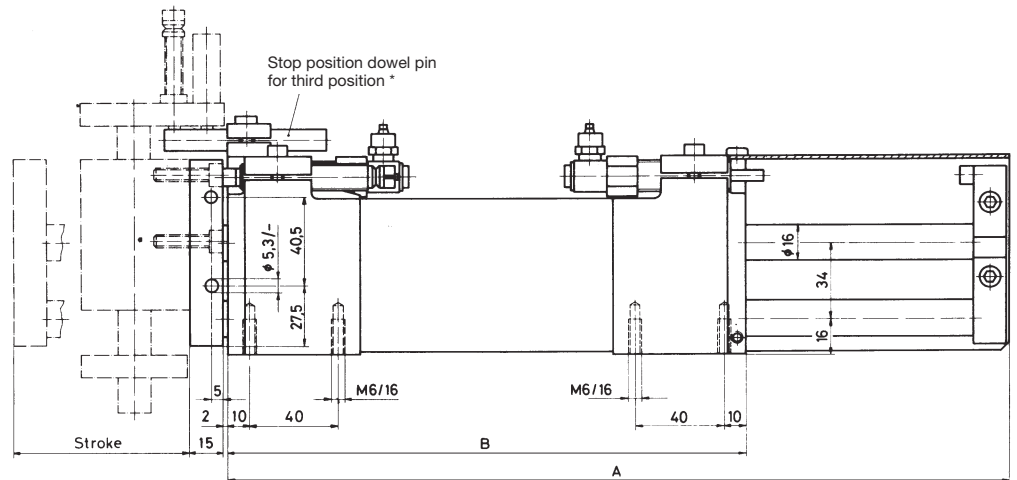
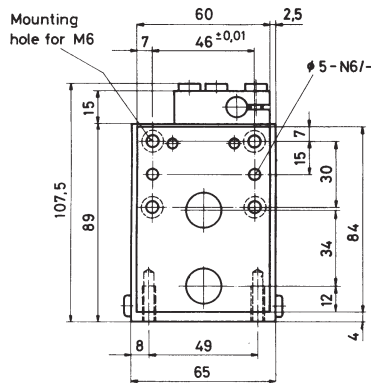
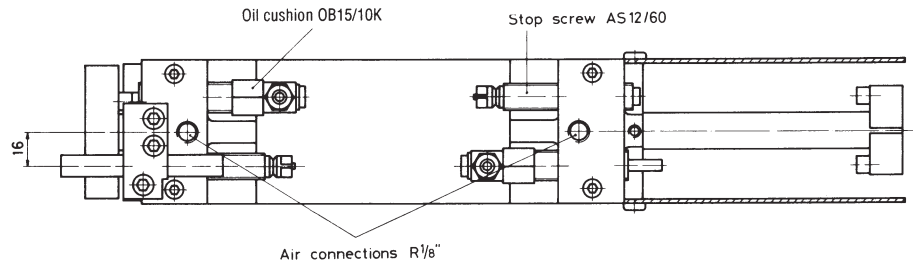
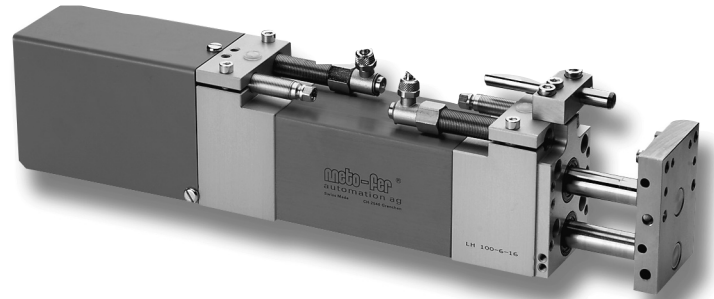

Type	Stroke (mm)	A (mm)	B (mm)	Piston force at 72.5 psi (5 bar)	Max. Load	Air consumption for each double stroke at 72.5 psi (5 bar)	Weight
LH 100	0–100	352	234	51 lb (226 N)	61.7 lb (28.0 kg)	.026 scf (0,73 NL)	11.0 lb (5,0 kg)
LH 150	0–150	452	284	51 lb (226 N)	35.3 lb (16.0 kg)	.038 scf (1,09 NL)	12.8 lb (5,8 kg)
LH 200	0–200	552	334	51 lb (226 N)	19.8 lb ( 9.0 kg)	.051 scf (1,45 NL)	14.6 lb (6,6 kg)
LH 300	0–300	752	434	51 lb (226 N)	9.9 lb (4,5 kg)	.077 scf (2,18 NL)	18.1 lb (8,2 kg)
LH 400	0–400	952	534	51 lb (226 N)	6.6 lb (3,0 kg)	.102 scf (2,90 NL)	21.6 lb (9,8 kg)

## Technical data:

- Stroke steplessly adjusted by built in patented stop screws with fine threads.
- The stop screws can be fitted with patented sensing elements. (see section "Stop Screws with plug-in sensing elements").
- End position damped with adjustable oil cushions.
- Designed for high operating rates / long life (expected life 20 million cycles)
- Seal repair kits available
- Linear ball bushings.
- Operating medium
- Operating pressure
- Repeatability
- Air connection

Compressed air oiled / not oiled  
43.5 – 116 psi (3 – 8 bar)  
± 0.01mm (0.0004")  
R 1/8" (adapter see sheet 5.032)

Order No. LH - . . . . .

O=Without cushions  
A=Elastomer cushions (KB08)  
B=Oil cushions and KOB50 (OB15/10K)  
Stroke / mm

# Intermediate position kit for LH

## Description:

The intermediate stop operates via a cylinder introducing a robust stop slide into the path of the horizontal units rear adjustable flange bracket to that is attached the stop screw and oil cushions. This stop assembly can be reversed to operate in either the forward or reverse mode. More than one intermediate stop may be fitted, minimum distance between them 30 mm. They must all operate in the same direction.

The intermediate position can be utilized both in forward or reverse modes.

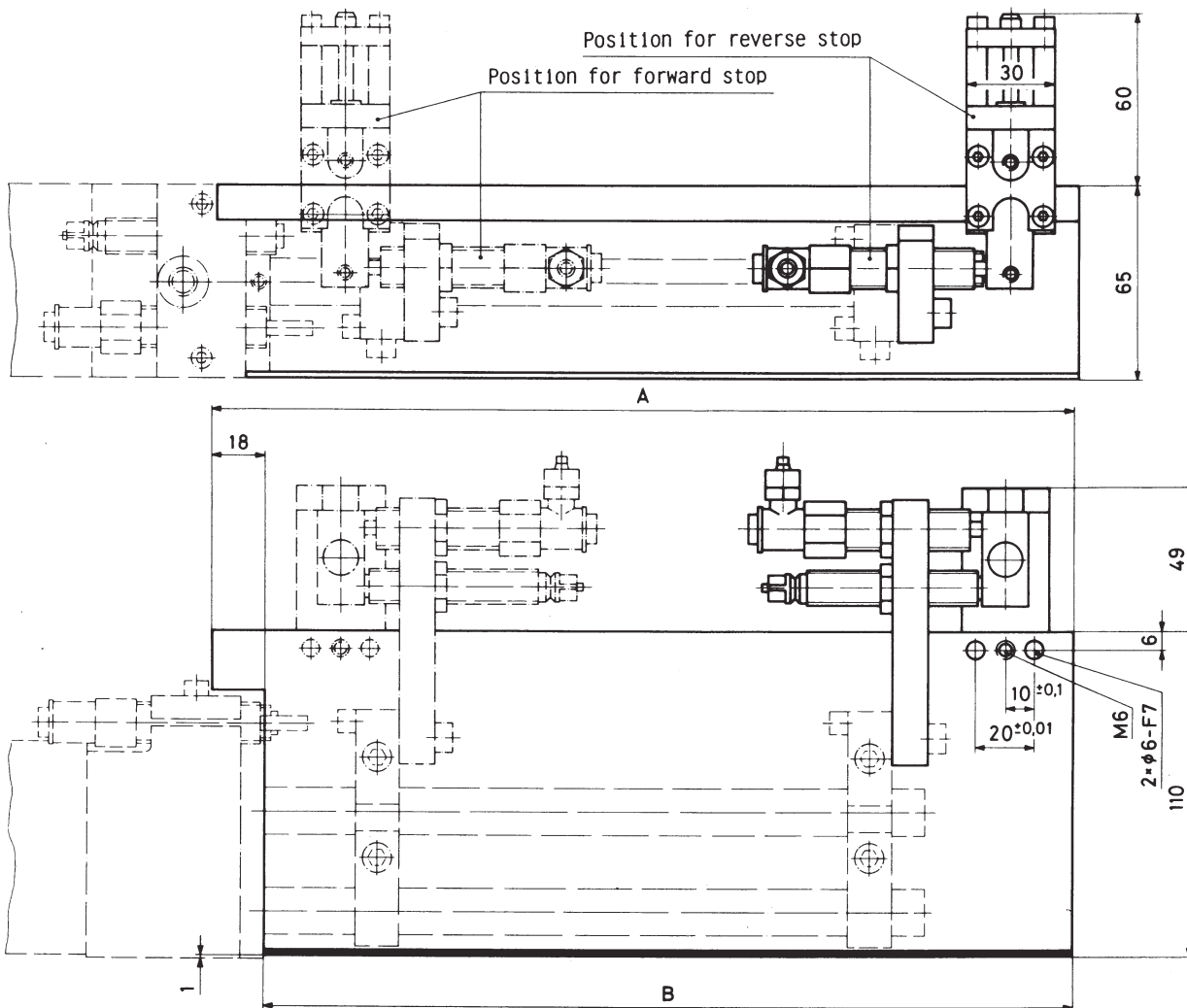

Intermediate kit complete for:	A (mm)	B (mm)	Intermediate kit with *SA 01 Order No.	Intermediate kit with *SA 01 A Order No.
LH 100	193	175	ZB 03.040	ZB 03.040 A
LH 150	243	225	ZB 03.035	ZB 03.035 A
LH 200	293	275	ZB 03.045	ZB 03.045 A
LH 300	393	375	ZB 03.050	ZB 03.050 A
LH 400	493	475	ZB 03.055	ZB 03.055 A

\* SA... = Stop slide see page 1.071

# Vertical Unit VE

In combination with mechanical gripper NW12 order NW25

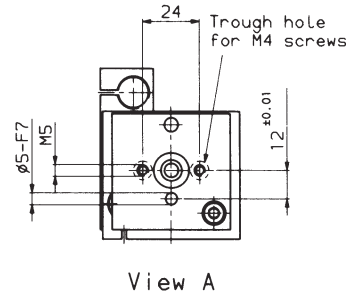
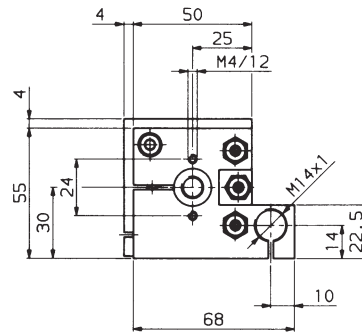
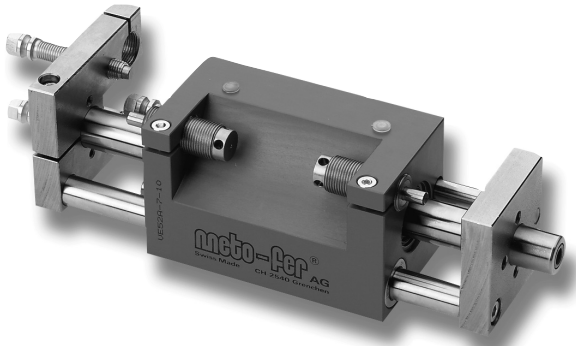

### Mounting of two vertical units

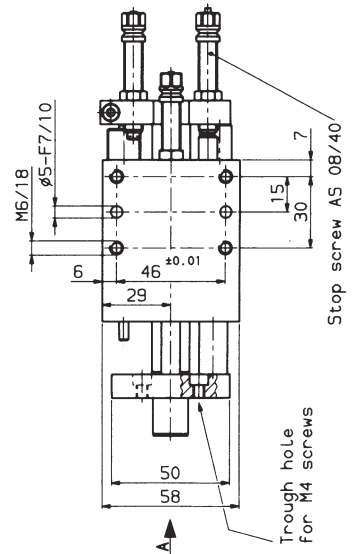
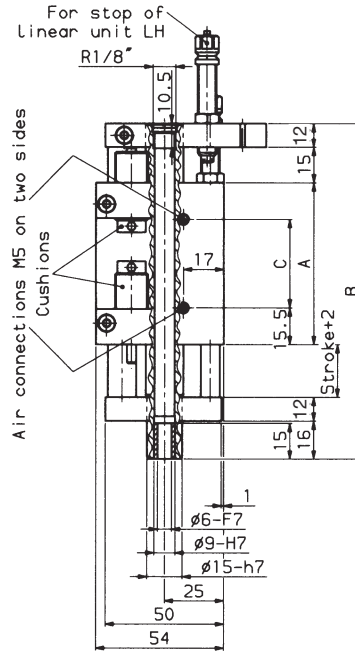
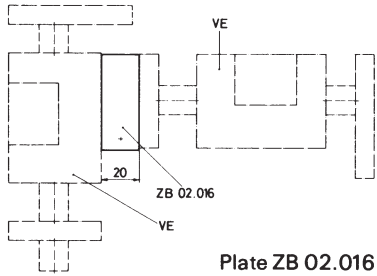

Type	Stroke (mm)	Adjusting range	A	B	C	Piston force at 72.5 psi (5 bar)	Air consumption for each double stroke at 72.5 psi (5bar)	Weight lb (kg)
VE-22	0-20	0-20	68	144	32	24lb (107N)	0.003scf (0.07NL)	2.4 (1.1)
VE-52	0-50	12-50	98	204	62	24lb (107N)	0.006scf (0.17NL)	3.1 (1.4)
VE-82	0-80	42-80	128	264	92	24lb (107N)	0.010scf (0.28NL)	3.7 (1.7)

Order No. VE-...  
 A = Elastomer cushions (Standard type)  
 Type

### Technical data:

- Built in stop screw with fine threads provide adjustable, stepless stroke.
- The stop screws can be fitted with patented sensing elements. (see section 8. "Stop system with plug-in sensing elements").
- End position damped with elastomer or oil cushions.
- Bearing: Linear ball bushing
- Positioning holes facilitate the assembly to the linear unit.
- Provision to add
  - Mechanical gripper
  - Vacuum head

- Operating medium: Compressed air oiled/ not oiled
- Operating pressure: 43.5 - 116 psi (3 - 8bar)
- Piston diameter: 25mm (1")
- Repeatability: +/- 0.01mm (0.0004")
- Air connection: M5

# Linear units LG 50

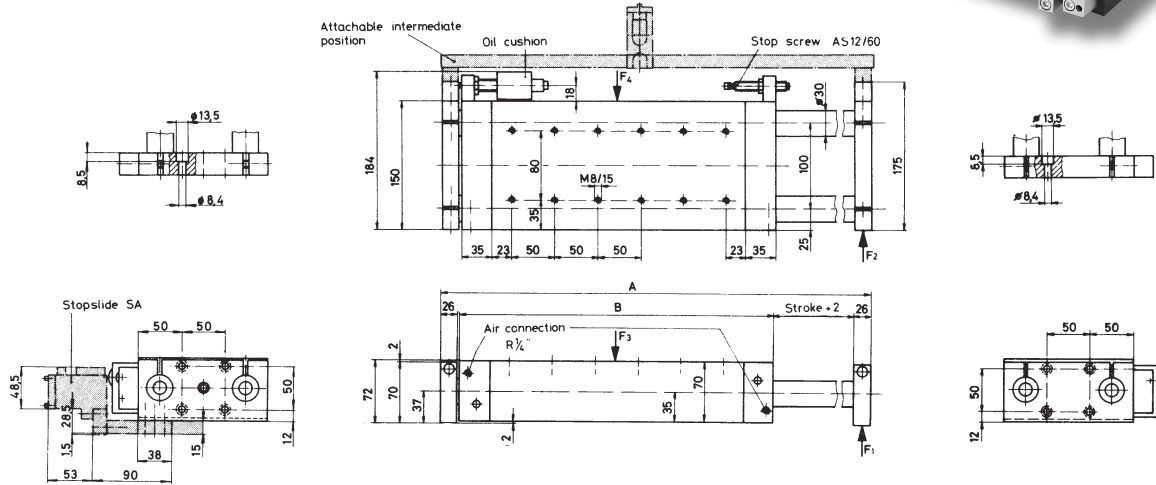

Type	Stroke (mm)	A (mm)	B (mm)	Piston force at 72.5 psi (5 bar)	Max load stat./dyn.				Mx (Nm)	My (Nm)	Mz (Nm)	Air consumption for each double stroke at 72.5 psi (5 bar)	Weight
					F1	F2	F3	F4					
LG 50/200	0-200	522	266	156 lb (694 N)	45 lb (200 N)	90 lb (400 N)	225 lb (1000 N)	292 lb (1300N)	50	114	148.2	.162 scf ( 4.58 NL)	23.4 lb (10.6 kg)
LG 50/300	0-300	722	366	156 lb (694 N)	34 lb (150 N)	70 lb (310 N)	169 lb ( 750N)	219 lb ( 975 N)	37.5	123	159.9	.243 scf ( 6.87 NL)	28.7 lb (13.0 kg)
LG 50/400	0-400	922	466	156 lb (694 N)	27 lb (120 N)	56 lb (250 N)	135 lb ( 600 N)	175 lb ( 780 N)	30	128.4	166.9	.323 scf ( 9.16 NL)	34.0 lb (15.4 kg)
LG 50/500	0-500	1122	566	156 lb (694 N)	20 lb ( 90N)	45 lb (200 N)	112 lb ( 500 N)	146 lb ( 650 N)	25	132	171.6	.404 scf (11.45 NL)	39.2 lb (17.8 kg)
LG 50/600	0-600	1322	666	156 lb (694 N)	18 lb ( 80 N)	38 lb (170 N)	90 lb ( 400 N)	117 lb ( 520 N)	20	125.6	163.6	.485 scf (13.73 NL)	44.5 lb (20.2 kg)
LG 50/800	0-800	1722	866	156 lb (694 N)	13 lb ( 60 N)	29 lb (130 N)	67 lb ( 300 N)	88 lb ( 390 N)	15	124.2	161.5	.647 scf (18.31 NL)	55.1 lb (25.0 kg)

**Order No.**

LG 50/ ... ..

C = without support for stopslide  
D = with support for stopslide

2 = Oil cushion OB 15/10 L  
4 = Oil cushion OB 12/20

A = without oil compensation reservoir  
B = with oil compensation reservoir

Type

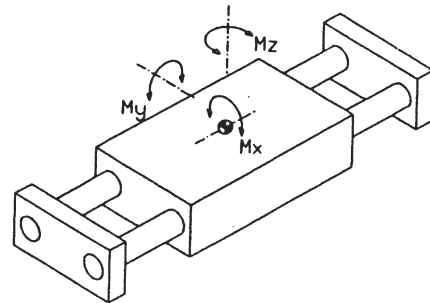

**Technical data:**

- Built in stop screws with fine threads provide adjustable, stepless stroke.
- The stop screws can be fitted with patented sensing elements (see section "Stop screws with plug in sensing elements").
- End position damped with adjustable oil cushions.
- Designed for high operating rates and long life.
- Bearing: Long life sleeve bearing.
- Attachable intermediate position.
- Piston  $\varnothing$  50mm (1,96")
- Operating medium: Compressed air oiled/ not oiled
- Operating pressure: 43.5–116 psi (3–8 bar)
- Repeatability:  $\pm$  0,01mm (.0004")
- Air connection: R 1/4" (adapter see sheet 5.021)



# Mini linear unit ML13

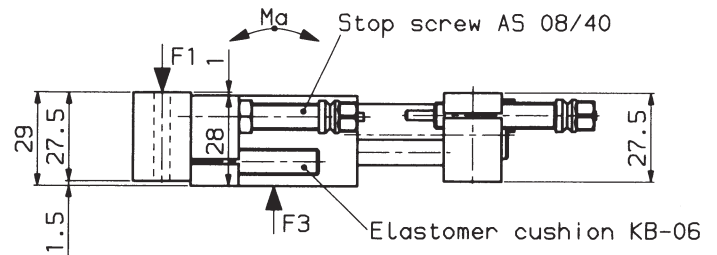
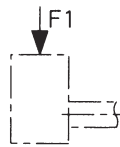
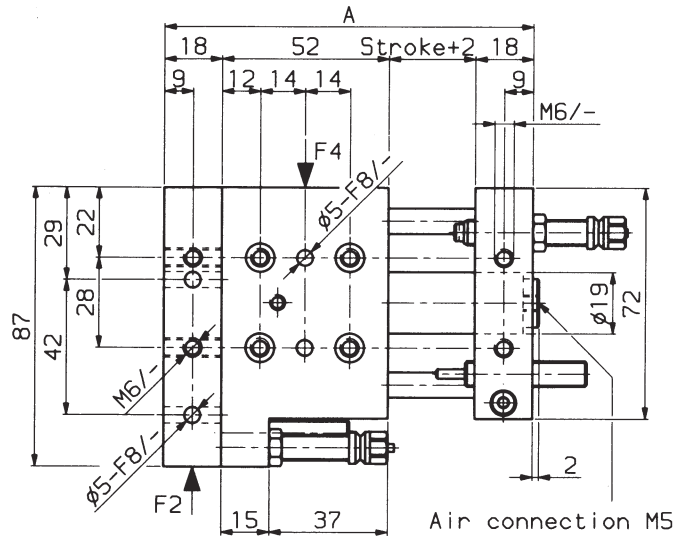
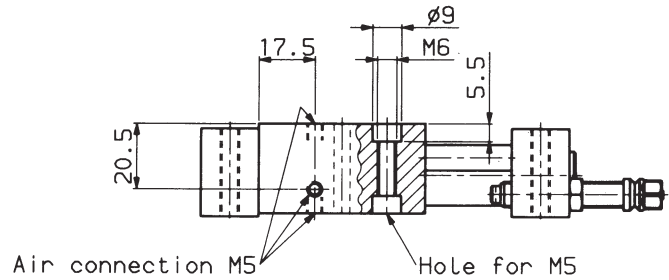
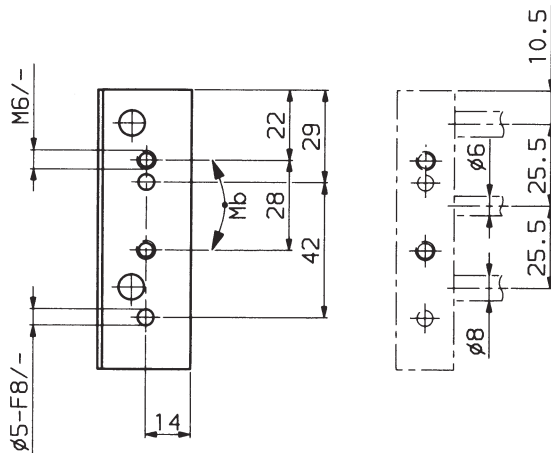
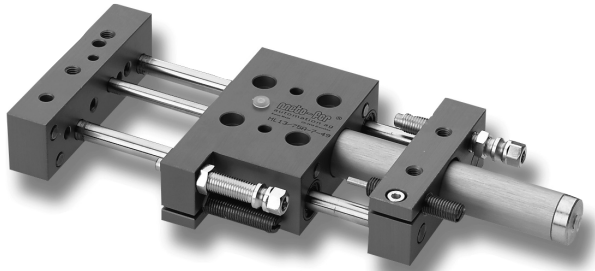

Type	Stroke (mm)	Adjusting range (mm)	A	Piston force at 72.5 psi (5 bar)	Max. load stat./dyn. lb (N)				Ma lb.in (Nm)	Mb lb.in (Nm)	Air consumption for each double stroke at 72.5 psi (5bar)	Weight lb (kg)
					F1	F2	F3	F4				
ML13-25	0-25	0-25	115	7lb (32N)	29 (131)	31 (137)	38 (167)	44 (196)	40 (4.5)	84 (9.5)	0.001scf (0.03NL)	1.5 (0.70)
ML13-50	0-50	13-50	140	7lb (32N)	19 (84)	20 (88)	43 (190)	44 (196)	40 (4.5)	84 (9.5)	0.002scf (0.06NL)	1.7 (0.76)
ML13-75	0-75	38-75	165	7lb (32N)	14 (62)	15 (65)	43 (190)	44 (196)	40 (4.5)	84 (9.5)	0.003scf (0.09NL)	1.8 (0.82)
ML13-100	0-100	63-100	190	7lb (32N)	9 (41)	10 (43)	43 (190)	44 (196)	40 (4.5)	84 (9.5)	0.004scf (0.12NL)	1.9 (0.88)

Order No. ML13 - . . . . .

O = Without cushions  
A = Elastomer cushions (Standard / M8X1)

Stroke

## Technical data:

- Built in stop screw with fine threads provide adjustable, stepless stroke.
- The stop screws can be fitted with patented sensing elements. (see section 8 "Stop system with plug-in sensing elements").
- End position damped with elastomer cushions.
- Bearing: Linear ball bushing.
- Operating medium Compressed air oiled/ not oiled
- Operating pressure 43.5 - 116 psi (3 - 8 bar)
- Piston diameter 12mm
- Repeatability +/- 0.01mm (0.0004")
- Air connection M5

# Mini linear unit ML26

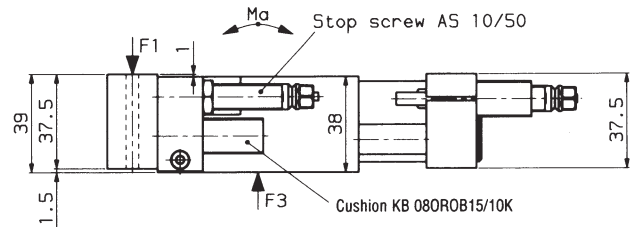
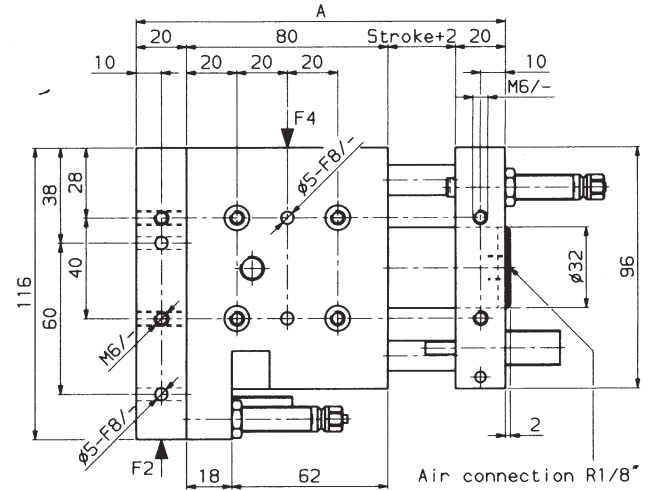
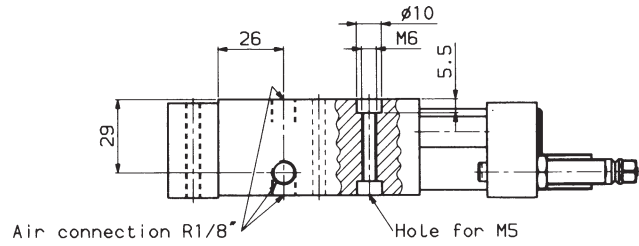
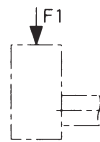
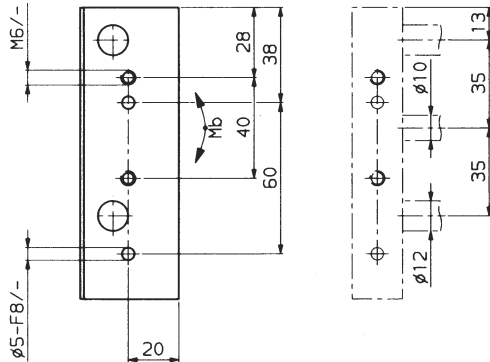
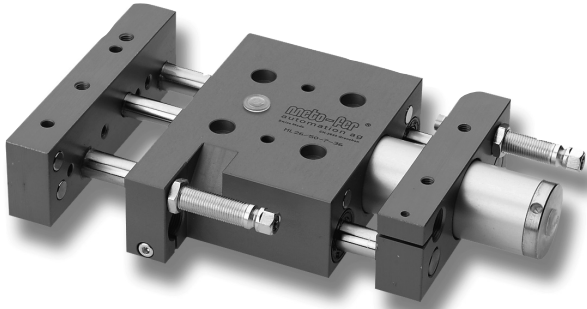

Type	Stroke	Adjusting range (mm)	A	Piston force at 72.5 psi (5 bar)	Max. load stat./dyn. lb (N)				Ma lb.in (Nm)	Mb lb.in (Nm)	Air consumption for each double stroke at 72.5 psi (5bar)	Weight lb (kg)
					F1	F2	F3	F4				
ML26-25	0-25	0-25	147	35lb (154N)	162 (721)	170 (754)	168 (746)	173 (770)	248 (28.0)	359 (40.5)	0.005scf (0.14NL)	3.7 (1.7)
ML26-50	0-50	0-50	172	35lb (154N)	91 (404)	95 (422)	175 (777)	179 (794)	199 (22.5)	297 (33.5)	0.009scf (0.27NL)	4.0 (1.8)
ML26-75	0-75	24-75	197	35lb (154N)	67 (297)	70 (311)	160 (712)	165 (734)	177 (20.0)	261 (29.5)	0.014scf (0.41NL)	4.2 (1.9)
ML26-100	0-100	49-100	222	35lb (154N)	49 (216)	51 (226)	139 (617)	143 (636)	159 (18.0)	230 (26.0)	0.019scf (0.54NL)	4.4 (2.0)
ML26-125	0-125	74-125	247	35lb (154N)	36 (162)	38 (169)	123 (546)	127 (563)	142 (16.0)	208 (23.5)	0.024scf (0.68NL)	4.6 (2.1)
ML26-150	0-150	99-150	272	35lb (154N)	31 (136)	32 (143)	117 (518)	123 (548)	137 (15.5)	199 (22.5)	0.028scf (0.81NL)	4.9 (2.2)
ML26-200	0-200	149-200	322	35lb (154N)	22 (99)	23 (104)	111 (494)	115 (509)	128 (14.5)	190 (21.5)	0.038scf (1.08NL)	5.5 (2.5)

Order No. ML 26 - . . . - . . .

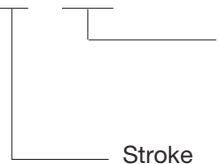

- O=Without cushions
- A=Elastomer cushions (Standard type), KB08
- B=Oil cushions without compensation reservoir, OB 15/10K
- C=Oil cushions with compensation reservoir (KOB50)

## Technical data:

- Built in stop screw with fine threads provide adjustable, stepless stroke.
- The stop screws can be fitted with patented sensing elements.  
(see section 8. "Stop system with plug-in sensing elements").
- End position damped with elastomer or oil cushion.
- Bearing: Linear ball bushing.
- Operating medium Compressed air oiled / not oiled
- Operating pressure 43.5 - 116 psi (3 - 8 bar)
- Piston diameter 25mm
- Repeatability +/- 0.01mm (0.0004")
- Air connection R1/8"

# Mini linear unit ML33

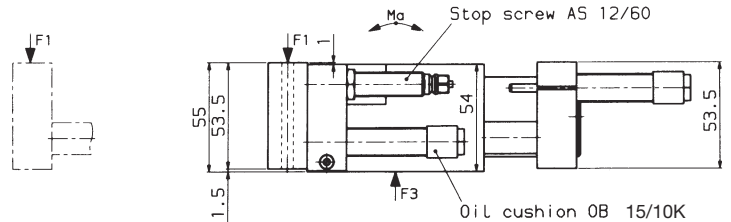
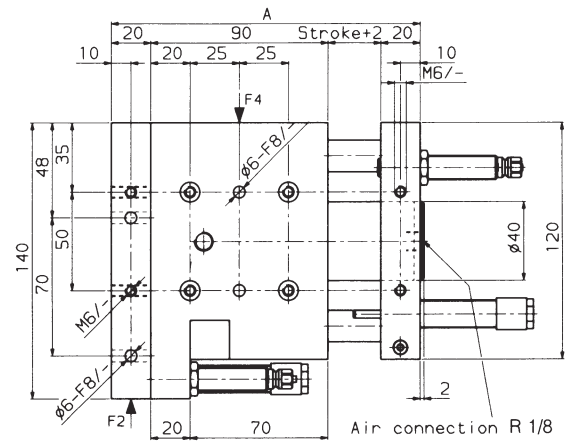
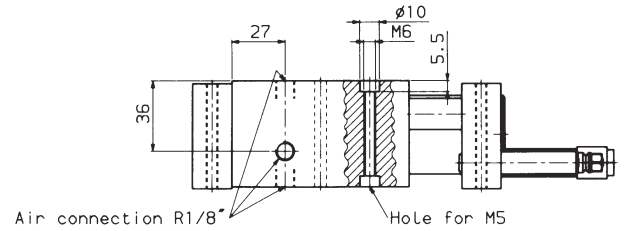
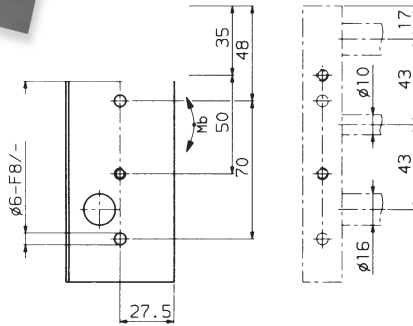

Type	Stroke (mm)	Adjusting range (mm)	A	Piston force at 72.5 psi (5 bar)	Max. load stat./dyn. lb (N)				Ma lb.in (Nm)	Mb lb.in (Nm)	Air consumption for each double stroke at 72.5 psi (5bar)	Weight lb (kg)
					F1	F2	F3	F4				
ML33-25	0-25	0-27	157	68lb (300N)	185 (823)	194 (861)	183 (814)	189 (840)	336 (38.0)	567 (64.0)	0.008scf (0.23NL)	8.9 (4.05)
ML33-50	0-50	0-52	182	68lb (300N)	112 (499)	117 (522)	221 (982)	228 (1013)	288 (32.5)	482 (54.5)	0.016scf (0.45NL)	9.4 (4.25)
ML33-75	0-75	8-77	207	68lb (300N)	77 (340)	80 (355)	195 (865)	201 (892)	252 (28.5)	420 (47.5)	0.024scf (0.67NL)	9.9 (4.50)
ML33-100	0-100	33-102	232	68lb (300N)	63 (281)	66 (295)	195 (865)	201 (892)	252 (28.5)	420 (47.5)	0.032scf (0.90NL)	10.4 (4.70)
ML33-125	0-125	58-127	257	68lb (300N)	46 (203)	48 (213)	164 (728)	169 (750)	212 (24.0)	354 (40.0)	0.039scf (1.12NL)	10.8 (4.90)
ML33-150	0-150	83-152	282	68lb (300N)	40 (178)	42 (168)	164 (728)	169 (750)	212 (24.0)	354 (40.0)	0.047scf (1.35NL)	11.4 (5.15)
ML33-175	0-175	108-177	307	68lb (300N)	33 (148)	35 (155)	153 (680)	158 (702)	199 (22.5)	332 (37.5)	0.055scf (1.57NL)	11.8 (5.35)
ML33-200	0-200	133-202	332	68lb (300N)	28 (125)	29 (131)	143 (637)	148 (657)	181 (20.5)	305 (34.5)	0.063scf (1.79NL)	12.2 (5.55)
ML33-250	0-250	183-252	382	68lb (300N)	23 (100)	24 (105)	137 (610)	141 (628)	177 (20.0)	297 (33.5)	0.078scf (2.24NL)	13.2 (6.00)
ML33-300	0-300	233-302	432	68lb (300N)	18 (79)	19 (83)	126 (561)	130 (578)	164 (18.5)	270 (30.5)	0.094scf (2.69NL)	14.1 (6.40)
ML33-350	0-350	283-352	482	68lb (300N)	15 (66)	16 (69)	120 (532)	124 (549)	155 (17.5)	261 (29.5)	0.110scf (3.14NL)	15.1 (6.85)
ML33-400	0-400	333-402	532	68lb (300N)	13 (57)	13 (59)	115 (512)	119 (528)	146 (16.5)	248 (28.0)	0.126scf (3.59NL)	16.0 (7.24)

Order No. ML 33 - . . . - . . .

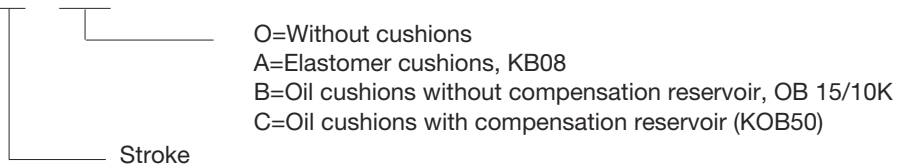

**Technical data:**

- Built in stop screw with fine threads provide adjustable, stepless stroke.
- The stop screws can be fitted with patented sensing elements. (see section 8 "Stop system with plug-in sensing elements").
- End position damped with elastomer or oil cushion.
- Bearing: Linear ball bushing.
- Operating medium Compressed air oiled/ not oiled
- Operating pressure 43.5 - 116 psi (3 - 8 bar)
- Piston diameter 32mm
- Repeatability +/- 0.01mm (0.0004")
- Air connection R1/8"

# Linear Unit ML 50

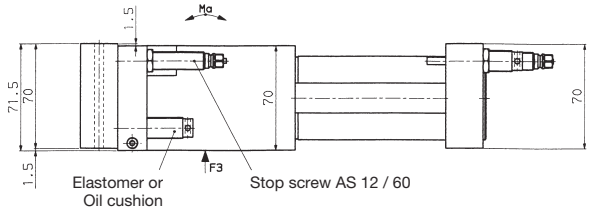
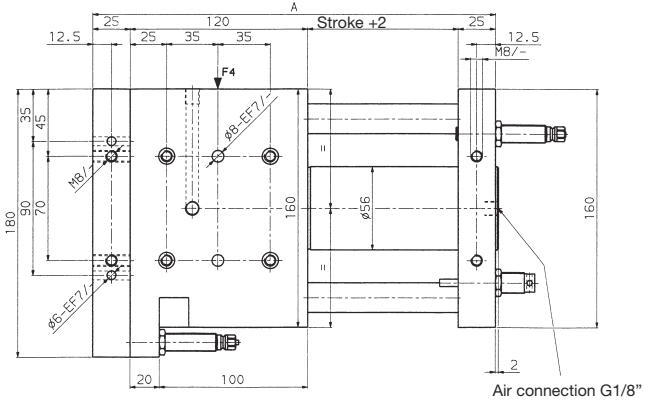
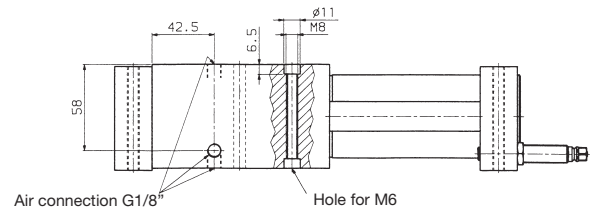
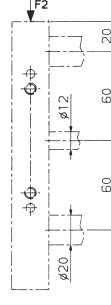
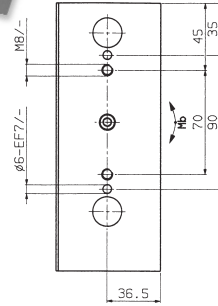
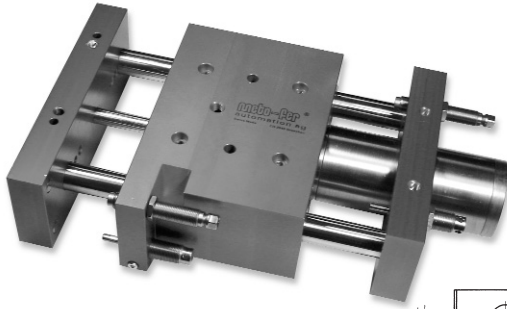

Type	Stroke (mm)	Adjustable Range (mm)	A (mm)	Piston Force @ 72.5 PSI (5 bar)	F1 lb. (N)	F2 lb. (N)	F3 lb. (N)	F4 lb. (N)	Ma lb. in (Nm)	Mb lb. in (Nm)	Air Consumption for each double stroke @ 72.5 PSI (5 bar)	Weight lb (kg)
ML 50-50	0-50	0-50	222	162 LB (722N)	168 (750)	168 (750)	247 (1100)	241 (1075)	371 (42)	531 (60)	0.040 scf (1.14 NL)	14.3 (6.5)
ML 50-75	0-75	25-75	247	162 LB (722N)	123 (550)	101 (450)	236 (1050)	229 (1020)	336 (38)	513 (58)	0.060 scf (1.71 NL)	14.9 (6.8)
ML 50-100	0-100	50-100	272	162 LB (722N)	89 (400)	78 (350)	220 (980)	218 (970)	318 (36)	487 (55)	0.080 scf (2.28 NL)	15.4 (7.0)
ML 50-150	0-150	100-150	322	162 LB (722N)	56 (250)	56 (250)	197 (880)	195 (870)	300 (34)	442 (50)	0.117 scf (3.43 NL)	16.5 (7.5)
ML 50-200	0-200	150-200	372	162 LB (722N)	42 (190)	42 (190)	170 (760)	173 (770)	274 (31)	416 (47)	0.161 scf (4.57 NL)	17.6 (8.0)
ML 50-250	0-250	200-250	422	162 LB (722N)	35 (160)	35 (160)	160 (710)	160 (710)	256 (29)	389 (44)	0.201 scf (5.72 NL)	17.4 (8.5)
ML 50-300	0-300	250-300	472	162 LB (722N)	29 (130)	31 (140)	146 (650)	148 (660)	239 (27)	354 (40)	0.242 scf (6.86 NL)	19.8 (9.0)
ML 50-400	0-400	350-400	572	162 LB (722N)	20 (90)	22 (100)	128 (570)	134 (600)	221 (25)	336 (38)	0.322 scf (9.15 NL)	22.0 (10.0)
ML 50-500	0-500	450-500	672	162 LB (722N)	16 (75)	16 (75)	121 (540)	126 (560)	186 (21)	327 (37)	0.403 scf (11.44 NL)	24.2 (11.0)

Order No. **ML 50** - . . . - . . .

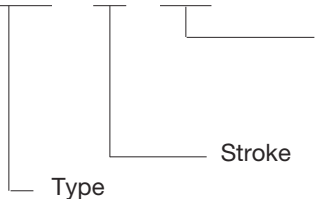

O=Without cushions  
 A=Elastomer cushions, KB08  
 B=Oil cushions without compensation reservoir, OB 15/10K  
 C=Oil cushions with compensation reservoir (KOB50)

## Technical data:

- Built in stop screw with fine threads provide adjustable, stepless stroke.
- The stop screws can be fitted with patented sensing elements. (see section 8. "stop system with plug-in sensing elements")
- End position damped with elastomer or oil cushion.
- Bearing: Linear ball bushing.
- Operating medium Compressed air oiled / not oiled
- Operating pressure 43.5 – 116 psi (3 – 8bar)
- Piston diameter 50mm
- Repeatability +/- 0.01mm (0.0004")
- Air connection G1/8

# Linear Unit LMP-60

Twin Rail

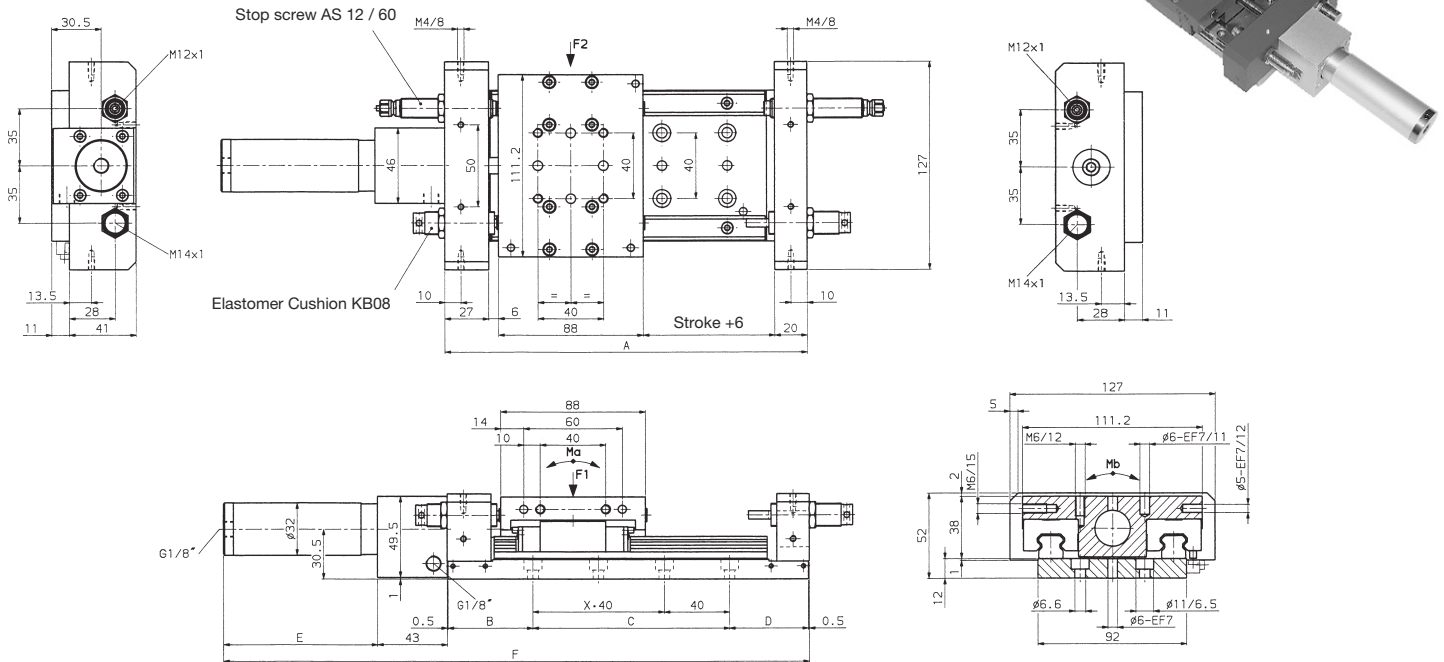

Stroke mm	Adjusting Range mm	A mm	B mm	C mm	D mm	E mm	F mm	X mm	Piston force @ 72.5 PSI (5 bar) lb (N)	F1 lb (N)	F2 lb (N)	Ma lb. in (Nm)	Mb lb. in (Nm)	Air Consumption for each double stroke @ 72.5 PSI (5 bar)	Weight lb (kg)
0-50	0-50	197	39.5	120	36.5	70	310	2	34 lb (154 N)	168 (750)	112 (500)	6.7 (30)	6.7 (30)	0.009 scf (0.27 NL)	8.3 (3.8)
0-75	24-75	222	52.0	120	49.0	95	360	2	34 lb (154 N)	168 (750)	112 (500)	6.7 (30)	6.7 (30)	0.014 scf (0.40 NL)	9.0 (4.1)
0-100	49-100	247	64.5	120	61.5	120	410	2	34 lb (154 N)	168 (750)	112 (500)	6.7 (30)	6.7 (30)	0.019 scf (0.54 NL)	9.7 (4.4)
0-150	99-150	297	89.5	120	86.5	170	510	2	34 lb (154 N)	168 (750)	112 (500)	6.7 (30)	6.7 (30)	0.065 scf (0.81 NL)	11.0 (5.0)
0-200	149-200	347	74.5	200	71.5	220	610	4	34 lb (154 N)	168 (750)	112 (500)	6.7 (30)	6.7 (30)	0.038 scf (1.08 NL)	12.3 (5.6)
0-250	199-250	397	99.5	200	96.5	270	710	4	34 lb (154 N)	168 (750)	112 (500)	6.7 (30)	6.7 (30)	0.047 scf (1.35 NL)	13.6 (6.2)
0-300	249-300	447	124.5	200	121.5	320	810	4	34 lb (154 N)	168 (750)	112 (500)	6.7 (30)	6.7 (30)	0.057 scf (1.62 NL)	15.2 (6.9)
0-400	349-400	547	174.5	200	171.5	420	1010	4	34 lb (154 N)	168 (750)	112 (500)	6.7 (30)	6.7 (30)	0.76 scf (2.16 NL)	17.8 (8.1)

## Order No. LMP 60 - . . . . .

**O**=Without cushions  
**A**=Elastomer cushions  
**B**=Oil cushions without compensation reservoir  
**C**=Oil cushions with compensation reservoir (KOB50)

**02**=Stroke 50      **06**=Stroke 150      **12**=Stroke 300  
**03**=Stroke 75      **08**=Stroke 200      **16**=Stroke 400  
**04**=Stroke 100      **10**=Stroke 250      Custom strokes available

Type

The units can also be used as x-y tables

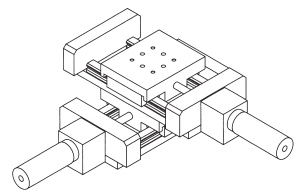

### Technical data:

- Built in stop screw with fine threads provide adjustable, stepless stroke.
- The stop screws can be fitted with patented sensing elements. (see section 8 "stop system with plug-in sensing elements")
- End position damped with elastomer or oil cushion.
- Linear twin rails with carriage.
- Operating medium Compressed air oiled / not oiled
- Operating pressure 43.5 – 116 PSI (3 – 8 bar)
- Piston diameter 25 mm
- Repeatability +/- 0.01mm (0.0004")
- Air connection G1/8"

- Easy mounting with the following units:
- LMP-60
  - LMP-60-A
  - LM-60-RW
  - LM-60-RWA

# Linear Unit LMP-60-A

Twin Rail with cover

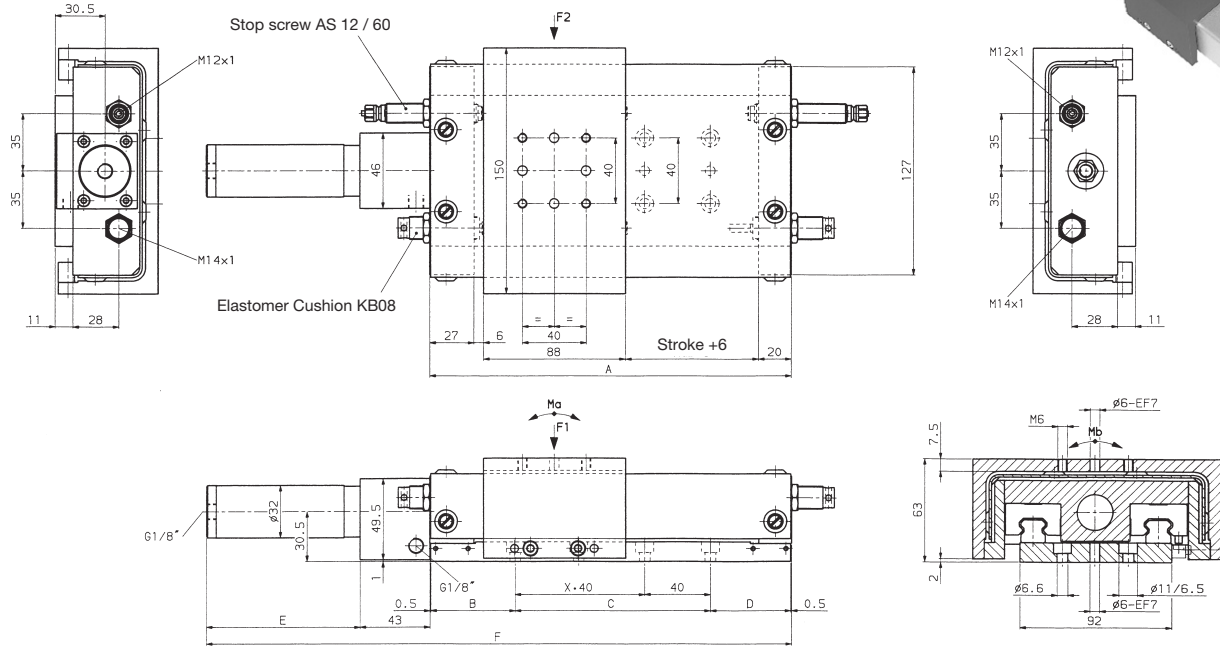

Stroke mm	Adjusting Range mm	A mm	B mm	C mm	D mm	E mm	F mm	X mm	Piston force @72.5 PSI (5 bar) lb (N)	F1 lb (N)	F2 lb (N)	Ma lb. in (Nm)	Mb lb. in (Nm)	Air Consumption for each double stroke @ 72.5 PSI (5 bar)	Weight lb (kg)
0-50	0-50	197	39.5	120	36.5	70	310	2	34 lb. (154 N)	168 (750)	112 (500)	6.7 (30)	6.7 (30)	0.009 scf (0.27 NL)	11.0 (5.0)
0-75	24-75	222	52.0	120	49.0	95	360	2	34 lb. (154 N)	168 (750)	112 (500)	6.7 (30)	6.7 (30)	0.014scf (0.40 NL)	11.6 (5.3)
0-100	49-100	247	64.5	120	61.5	120	410	2	34 lb. (154 N)	168 (750)	112 (500)	6.7 (30)	6.7 (30)	0.019 scf (0.54 NL)	12.3 (5.6)
0-150	99-150	297	89.5	120	86.5	170	510	2	34 lb. (154 N)	168 (750)	112 (500)	6.7 (30)	6.7 (30)	0.065 scf (0.81 NL)	13.8 (6.3)
0-200	149-200	347	74.5	200	71.5	220	610	4	34 lb. (154 N)	168 (750)	112 (500)	6.7 (30)	6.7 (30)	0.038 scf (1.08 NL)	15.2 (6.9)
0-250	199-250	397	99.5	200	96.5	270	710	4	34 lb. (154 N)	168 (750)	112 (500)	6.7 (30)	6.7 (30)	0.047 scf (1.35 NL)	16.5 (7.5)
0-300	249-300	447	124.5	200	121.5	320	810	4	34 lb. (154 N)	168 (750)	112 (500)	6.7 (30)	6.7 (30)	0.057 scf (1.62 NL)	18.3 (8.3)
0-400	349-400	547	174.5	200	171.5	420	1010	4	34 lb. (154 N)	168 (750)	112 (500)	6.7 (30)	6.7 (30)	0.76 scf (2.16 NL)	21.1 (9.6)

Order No. LMP 60A - . . . - . . .

O=Without cushions  
 A=Elastomer cushions  
 B=Oil cushions without compensation reservoir  
 C=Oil cushions with compensation reservoir (KOB50)

02=Stroke 50      06=Stroke 150      12=Stroke 300  
 03=Stroke 75      08=Stroke 200      16=Stroke 400  
 04=Stroke 100    10=Stroke 250      Custom strokes available

Type

The units can also be used as x-y tables

## Technical data:

- Built in stop screw with fine threads provide adjustable, stepless stroke.
- The stop screws can be fitted with patented sensing elements. (see section 8. "stop system with plug-in sensing elements")
- End position damped with elastomer or oil cushion.
- Linear twin rails with carriage.
- Operating medium
- Operating pressure
- Piston diameter
- Repeatability
- Air connection

Compressed air oiled / not oiled  
 43.5 – 116 PSI (3 – 8 bar)  
 25 mm  
 +/- 0.01mm (0.0004")  
 G1/8"

Easy mounting with the following units:  
 -LMP-60  
 -LMP-60-A  
 -LM-60-RW  
 -LM-60-RWA

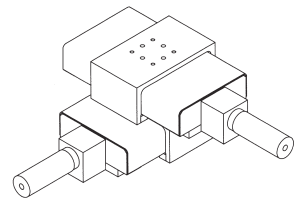

# Linear Unit LKP-100

Twin Rail with band cover

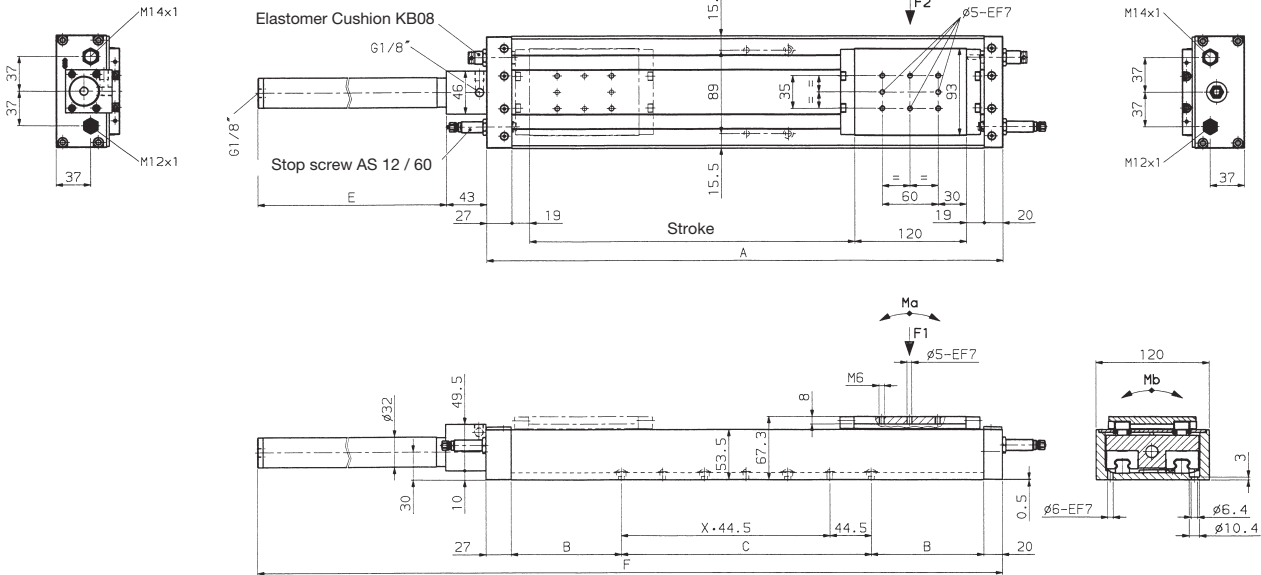

Stroke mm	Adjusting Range mm	A mm	B mm	C mm	E mm	F mm	X mm	Piston force@ 72.5PSI(5bar) lb (N)	F1 lb (N)	F2 lb (N)	Ma lb. in (Nm)	Mb lb. in (Nm)	Air Consumption for each double stroke @ 72.5 PSI (5 bar)	Weight lb (kg)
0-50	0-50	255	59.5	89	104	402	1	34 (154 N)	168 (750)	112 (500)	265 (30)	265 (30)	0.009 scf (0.27 NL)	13.4 (6.1)
0-75	25-75	280	72	89	129	452	1	34 (154 N)	168 (750)	112 (500)	265 (30)	265 (30)	0.014 scf (0.40 NL)	14.5 (6.6)
0-100	50-100	305	84.5	89	154	502	1	34 (154 N)	168 (750)	112 (500)	265 (30)	265 (30)	0.019 scf (0.54 NL)	15.4 (7.0)
0-150	100-150	355	109.5	89	204	602	1	34 (154 N)	168 (750)	112 (500)	265 (30)	265 (30)	0.028 scf (0.81 NL)	16.5 (7.5)
0-200	150-200	405	134.5	89	254	702	1	34 (154 N)	168 (750)	112 (500)	265 (30)	265 (30)	0.038 scf (1.08 NL)	18.7 (8.0)
0-250	200-250	455	70.5	267	304	802	5	34 (154 N)	168 (750)	112 (500)	265 (30)	265 (30)	0.047 scf (1.35 NL)	18.7 (8.5)
0-300	250-300	505	95.5	267	354	902	5	34 (154 N)	168 (750)	112 (500)	265 (30)	265 (30)	0.057 scf (1.62 NL)	19.8 (9.0)
0-400	350-400	605	145.5	267	454	1102	5	34 (154 N)	168 (750)	112 (500)	265 (30)	265 (30)	0.76 scf (2.16 NL)	21.8 (9.9)
0-500	450-500	705	195.5	267	554	1302	5	34 (154 N)	168 (750)	112 (500)	265 (30)	265 (30)	0.095 scf (2.71 NL)	24.0 (10.9)

Order No. LKP 100 - . . . - . . .

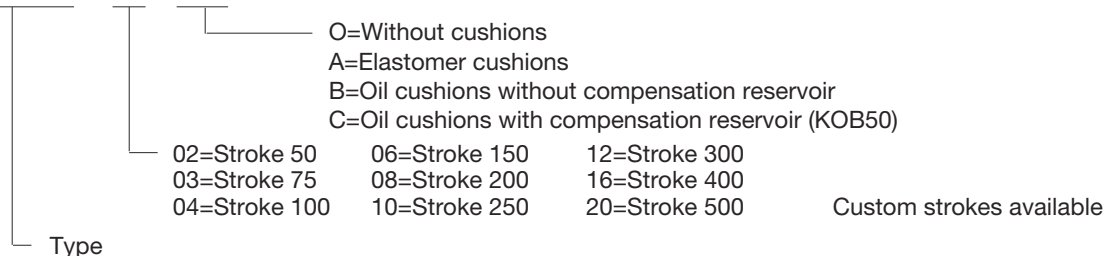

**Technical data:**

- Built in stop screw with fine threads provide adjustable, stepless stroke.
- The stop screws can be fitted with patented sensing elements. (see section 8. "stop system with plug-in sensing elements")
- End position damped with elastomer or oil cushion.
- Twin rails with carriage.
- Operating medium    Compressed air oiled / not oiled
- Operating pressure     43.5 – 116 PSI (3 – 8 bar)
- Piston diameter    25 mm
- Repeatability     +/- 0.01mm (0.0004")
- Air connection    G1/8"

# Linear Unit LKP-100-A

Twin Rails

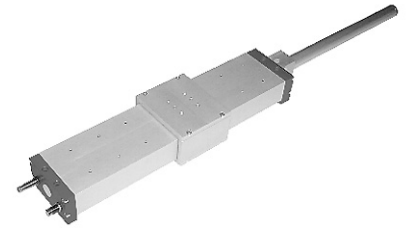
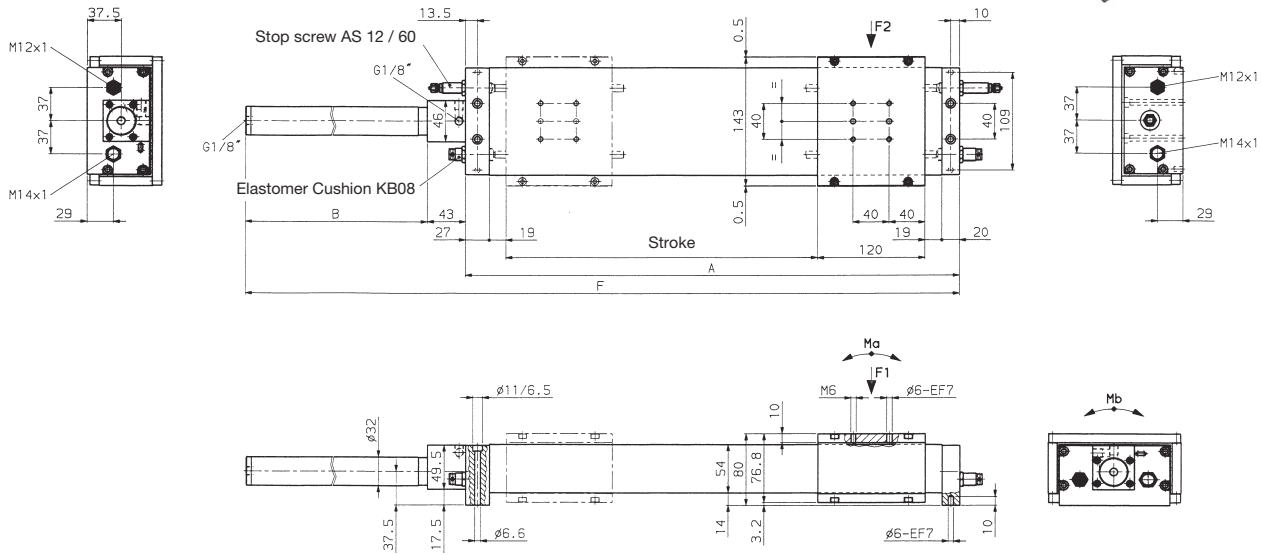

Stroke mm	Adjusting Range mm	A mm	B mm	F mm	X mm	Piston force@ 72.5 PSI (5bar)	F1 lb (N)	F2 lb (N)	Ma lb. in (Nm)	Mb lb. in (Nm)	Air Consumption for each double stroke @ 72.5 PSI (5 bar)	Weight lb (kg)
0-50	0-50	255	59.5	402	1	34 (154 N)	168 (750)	112 (500)	265 (30)	265 (30)	0.009 scf (0.27 NL)	13.8 (6.3)
0-75	25-75	280	72.0	452	1	34 (154 N)	168 (750)	112 (500)	265 (30)	265 (30)	0.014 scf (0.40 NL)	14.3 (6.5)
0-100	50-100	305	84.5	502	1	34 (154 N)	168 (750)	112 (500)	265 (30)	265 (30)	0.019 scf (0.54 NL)	14.7 (6.7)
0-150	100-150	355	109.5	602	1	34 (154 N)	168 (750)	112 (500)	265 (30)	265 (30)	0.028 scf (0.81 NL)	15.6 (7.1)
0-200	150-200	405	134.5	702	1	34 (154 N)	168 (750)	112 (500)	265 (30)	265 (30)	0.038 scf (1.08 NL)	16.5 (7.5)
0-250	200-250	455	70.5	802	5	34 (154 N)	168 (750)	112 (500)	265 (30)	265 (30)	0.047 scf (1.35 NL)	17.4 (7.9)
0-300	250-300	505	95.5	902	5	34 (154 N)	168 (750)	112 (500)	265 (30)	265 (30)	0.057 scf (1.62 NL)	18.5 (8.4)
0-400	350-400	605	145.5	1102	5	34 (154 N)	168 (750)	112 (500)	265 (30)	265 (30)	0.076 scf (2.16 NL)	20.2 (9.2)
0-500	450-500	705	195.5	1302	5	34 (154 N)	168 (750)	112 (500)	265 (30)	265 (30)	0.095 scf (2.71 NL)	22.2 (10.1)

Order No. LKP 100A - . . . - . . .

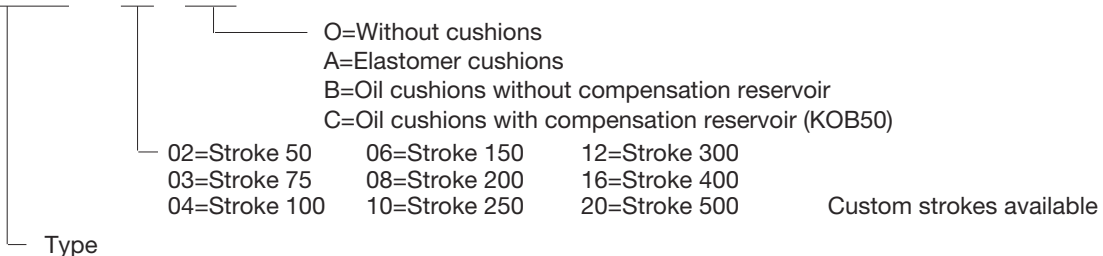

### Technical data:

- Built in stop screw with fine threads provide adjustable, stepless stroke.
- The stop screws can be fitted with patented sensing elements. (see section 8. "stop system with plug-in sensing elements")
- End position damped with elastomer or oil cushion.
- Twin rails with carriage.
- Operating medium Compressed air oiled / not oiled
- Operating pressure 43.5 – 116 PSI (3 – 8 bar)
- Piston diameter 25 mm
- Repeatability +/- 0.01mm (0.0004")
- Air connection G1/8"



# Standard roller slide NT 61

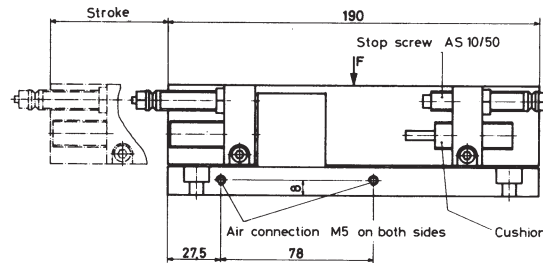
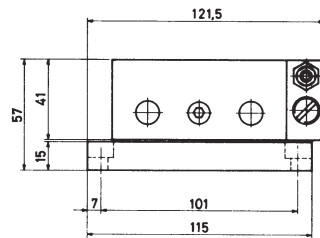
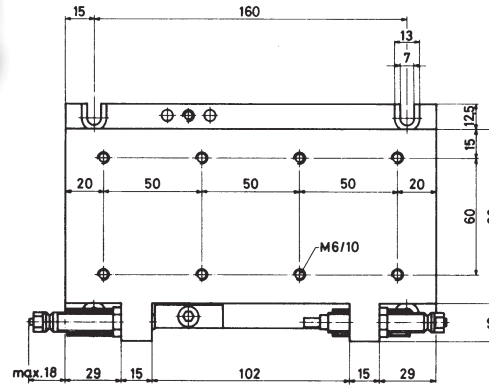
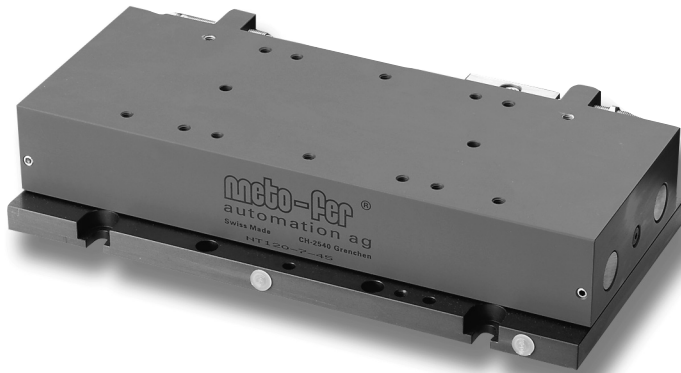

Type	Stroke (mm)	Piston force at 72.5 psi (5 bar)	Max. load F stat.	Max. load F dyn.	Air consumption for each double stroke at 72.5 psi (5 bar)	Weight
NT 61	0–60	35 lb (154 N)	337 lb (1500 N)	214 lb (950 N)	.013 scf (0,36 NL)	5.5 lb (2,5 kg)

## Order No.

NT 61 – . . .

- O = without cushions
- A = with elastomer cushions (standard type)
- B = with oil cushions, without compensation reservoir
- C = with oil cushions, with compensation reservoir (KOB50)

Standard roller slide NT 61

## Technical data:

- Built in stop screw with fine threads provide adjustable, stepless stroke.
- The stop screws can be fitted with patented sensing elements. (see section 8"Stop system with plug-in sensing elements").
- End position damped with adjustable elastomer or oil cushion.
- Designed for high operating rates and long life
- Bearing: Linear ball bushing.
- Operating medium                       Compressed air or hydraulic oil
- Operating pressure                      43.5 - 116 psi (3 - 8 bar)
- Piston diameter
- Repeatability                              +/- 0.01mm (0.0004")
- Air connection                             M5

# Standard roller slide NT 120

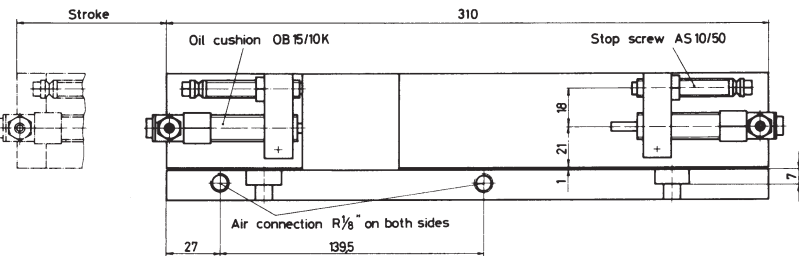
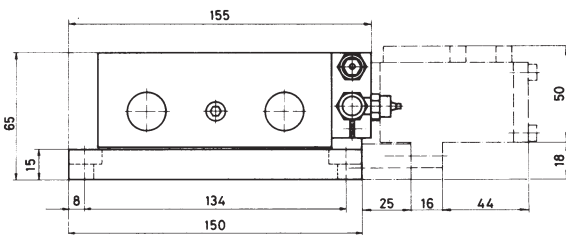
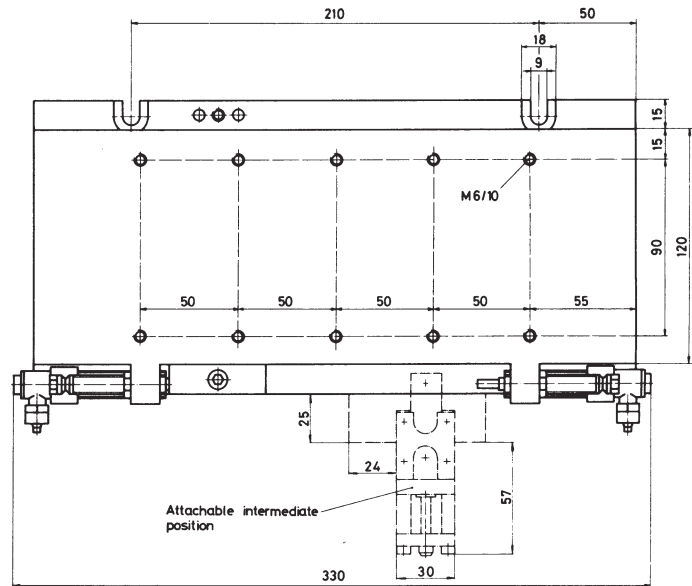
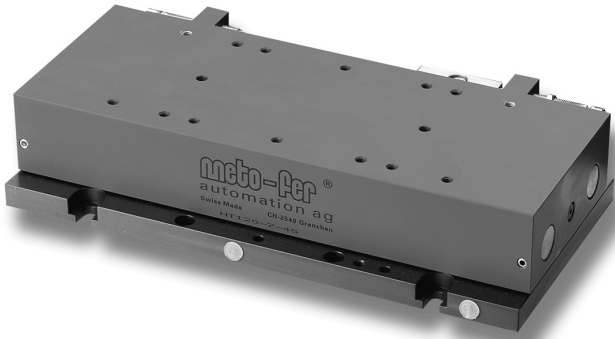

Type	Stroke (mm)	Piston force at 72.5 psi (5 bar)	Max. load F stat.	Max. load F dyn.	Air consumption for each double stroke at 72.5 psi (5 bar)	Weight
NT 120	0-120	53 lb (235 N)	540 lb (2400 N)	360 lb (1600 N)	.032 scf (0,91 NL)	14.3 lb (6,5 kg)

## Order No.

NT120-0 O = without cushions  
 NT120-A A = with oil cushions, without compensation reservoir  
 NT120-B B = with oil cushions, with compensation reservoir

**Intermediate position to NT 120:** Stop screw assembly for NT and stop slide SA

**Order No.** see sheet 1.071

## Technical data:

- Built in stop screw with fine threads provide adjustable, stepless stroke.
- The stop screws can be fitted with patented sensing elements. (see section 8 "Stop system with plug-in sensing elements").
- End position damped with adjustable oil cushions.
- Designed for high operating rates and long life
- Intermediate position can be added
- Bearing: Linear ball bushing
- Operating medium Compressed air or hydraulic oil
- Operating pressure 43.5 - 116 psi (3 - 8 bar)
- Repeatability +/- 0.01mm (0.0004")
- Air connections R 1/8"

# Elevating table HT

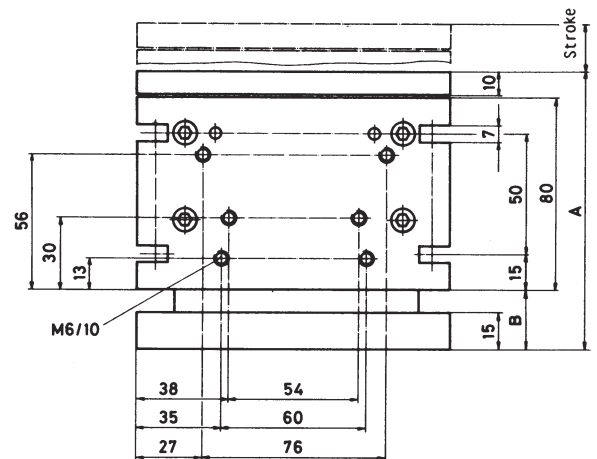
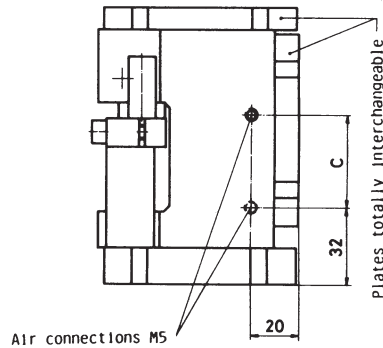
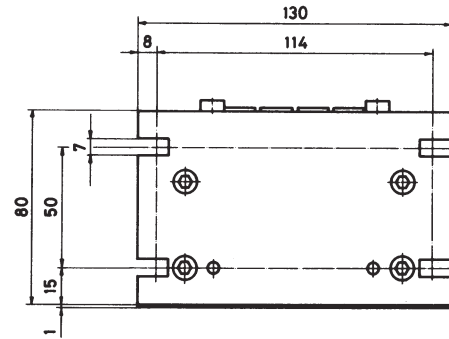
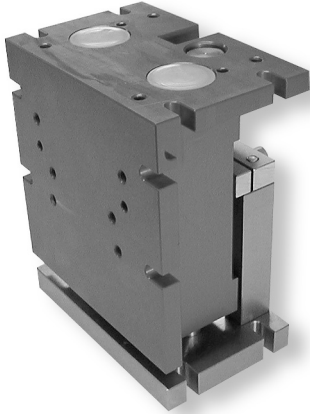
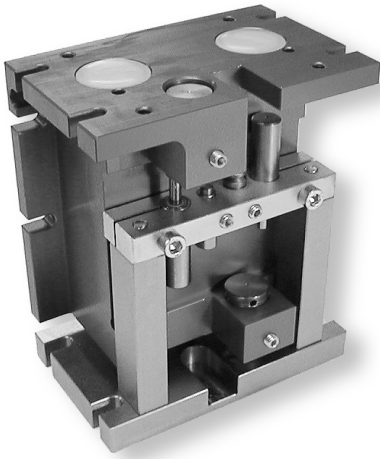

Type	Stroke (mm)	A	B	C	Piston force at 72.5 psi (5 bar)	Air consumption for each double stroke at 72.5 psi (5 bar)	Weight
HT 20	0–20	115	24	38	61 lb (272 N)	.007 scf (0,19 NL)	10.1 lb (4,6 kg)
HT 50 K	0–50	147	56	68	61 lb (272 N)	.016 scf (0,46 NL)	11.2 lb (5,1 kg)

### Order No.

HT 20 A  
HT 20 B  
HT 20 C

HT 50 KA  
HT 50 KB  
HT 50 KC

A = with elastomer cushions (standard type)  
B = with oil cushions, without compensation reservoir  
C = with oil cushions, with compensation reservoir

### Technical data:

- Built in stop screw with fine threads provide adjustable, stepless stroke.
- The stop screws can be fitted with patented sensing elements. (see section 8"Stop system with plug-in sensing elements").
- End position damped with adjustable elastomer or oil cushions.
- Designed for high operating rates and long life
- Bearing: Linear ball bushing
- Operating medium  
Compressed air or hydraulic oil
- Operating pressure  
43.5 - 116 psi (3 - 8 bar)
- Repeatability  
+/- 0.01mm (0.0004")
- Air connections  
M5

# Elevating table HT

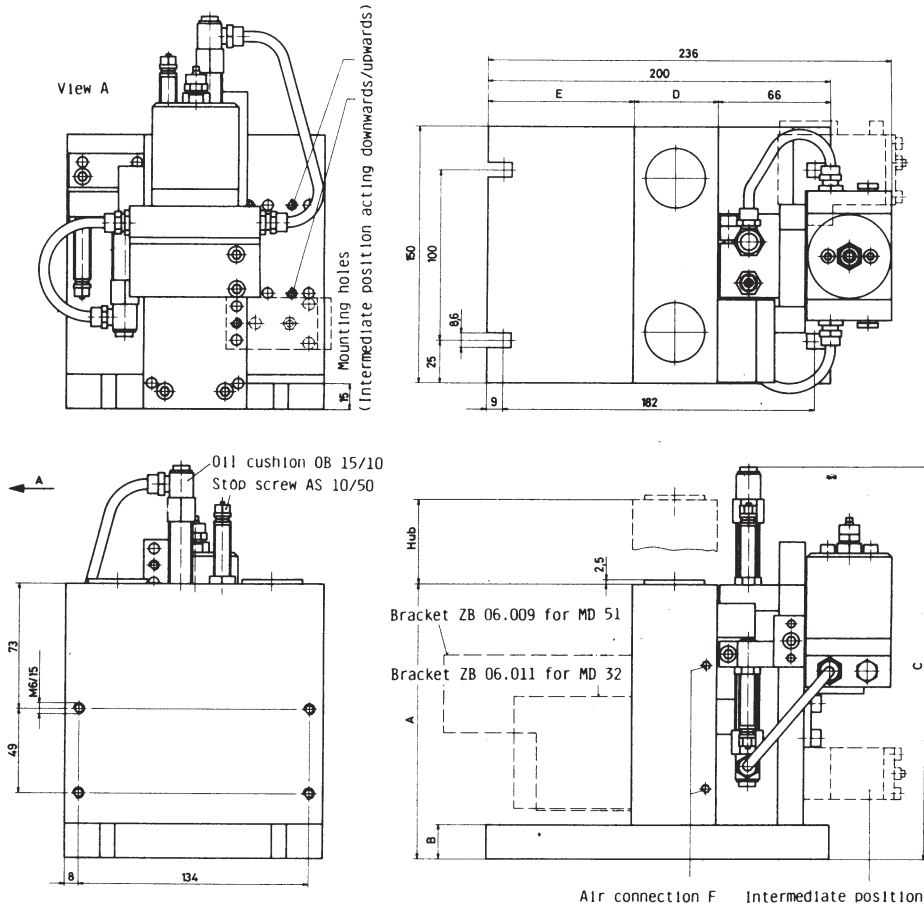

### Intermediate position to HT 50 & HT 100

Stop screw assembly for HT and stop slide SA

**Order No.** see sheet 1.071

Using an intermediate position the programs featured below can be carried out.

Other programs can also be carried out on this basis.

HT 100 with intermediate position.

Type	Stroke (mm)	A	B	C	D	E	F	Piston force at 72.5 psi (5 bar)	Air consumption for each double stroke at 72.5 psi (5 bar)	Weight
HT 50	0-50	160	20	230	48	86	M5	61 lb (272 N)	.016 scf (0,46 NL)	22.1 lb (10 kg)
HT 100	0-100	232	25	302	70	64	R 1/8	156 lb (694 N)	.081 scf (2,29 NL)	33.1 lb (15 kg)

### Order No.

HT 50                      HT 100  
 HT 50 A                HT 100 A            A = Intermediate position with \* SA 01  
 HT 50 B                HT 100 B            B = Intermediate position with \* SA 01 A

\* SA... = Stop slide see sheet 1.071

### Technical data:

- Built in stop screw with fine threads provide adjustable, stepless stroke.
- The stop screws can be fitted with patented sensing elements. (see section 8"Stop system with plug-in sensing elements").
- End position damped with adjustable oil cushions.
- Designed for high operating rates and long life
- Intermediate position can be added.
- Bearing: Linear ball bushing (HT 50) / Long life sleeve bearing (HT 100)
- Operating medium                      Compressed air or hydraulic oil
- Operating pressure                      43.5 - 116 psi (3 - 8 bar)
- Repeatability                              +/- 0.01mm (0.0004")
- Air connections                            See table

# Stopslide SA

The stop slide cylinder is a robust double acting cylinder which may be fitted to most of the linear slide units as an intermediate stop device.

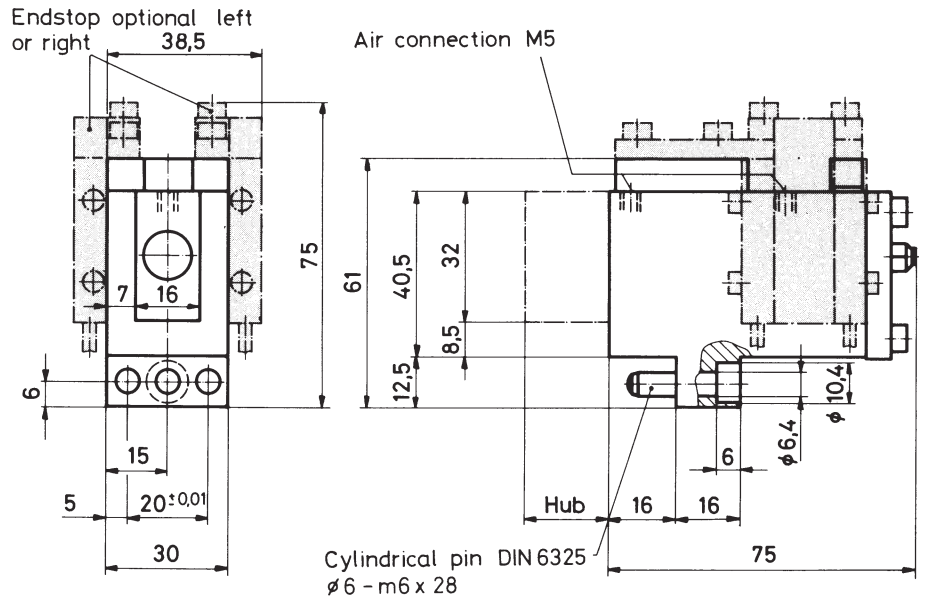
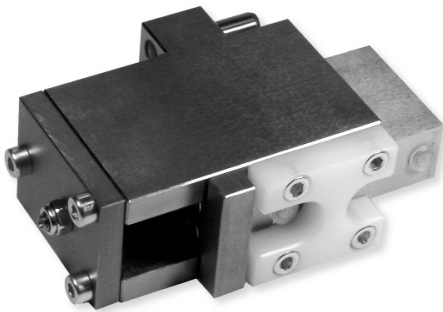

Type	Stroke (mm)	Piston force at 72.5 psi (5 bar)	Air consumption for each double stroke at 72.5 psi (5 bar)	Weight
SA 01	0–20	8 lb (35 N)	.001 scf (0,03 NL)	1.5 lb (0,7 kg)

**Order No.**

- SA 01 without bracket
- SA 01 A A = with bracket for sensors (IM008)

**Technical data:**

- Operating medium Compressed air or hydraulic oil
- Operating pressure 43.5–116 psi (3–8 bar)
- Air connection M5
- Material of construction Steel, slide piston hardened

Sensor Order No.: IM-008-NS-U2L (NPN)  
IM-008-PS-U2L (PNP)

# Stopscrew assembly

The stopscrew and cushion assembly is available as an accessory.  
The oil reservoir is not included.

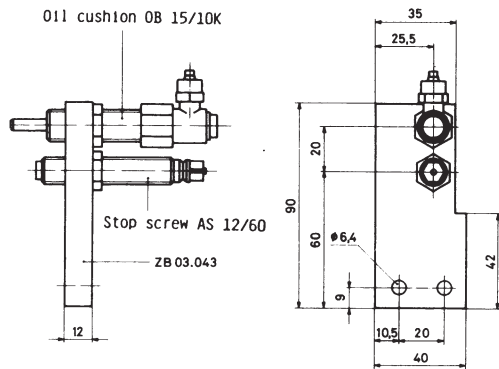

**Stopscrew assembly for LH**  
Order No. ZB 03.005

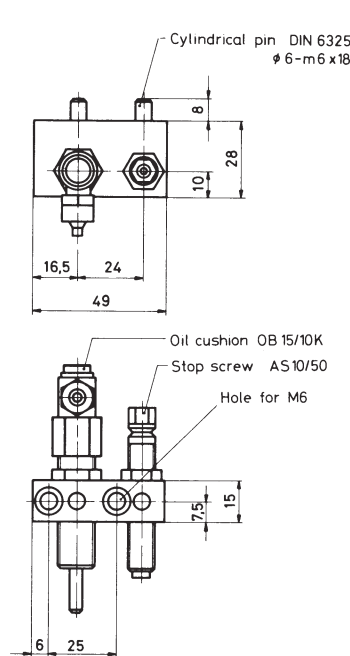

**Stopscrew assembly for HT**  
Order No. ZB 06.015

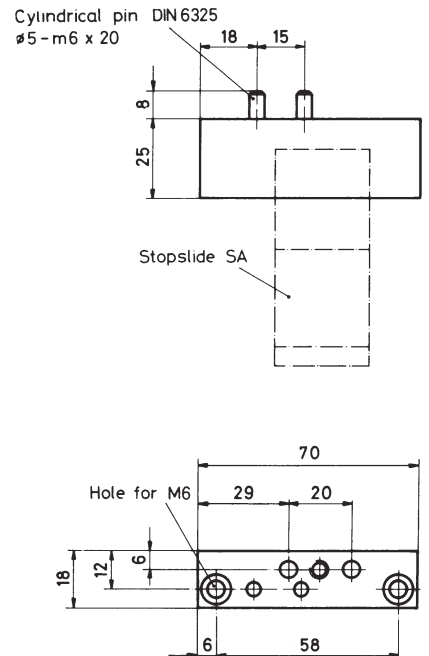

**Stopscrew assembly for NT 120**  
Order No. ZB 16.005

# Pick and Place

Complete station with linear unit, vertical unit and stand

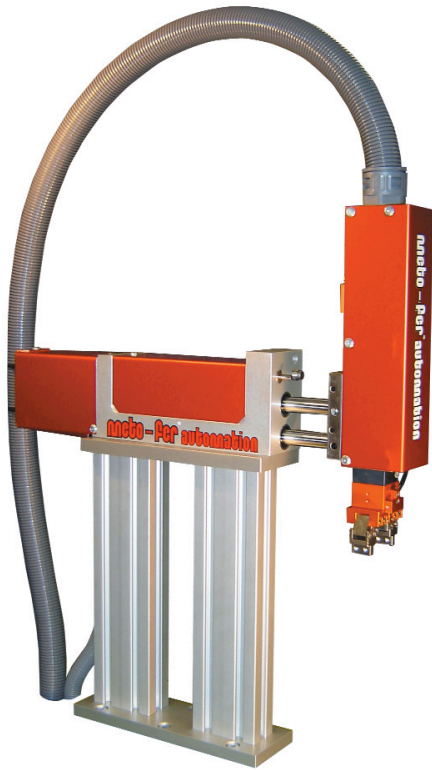

- Linear Unit with integrated flow controls and precision stop system and cushions
- Vertical Unit with cushions and precision stop system (stop screw) third down position on vertical unit in home position of linear unit
- Easy Gripper / Rotary modular assembly with standard components
- Expected life: 20-25 million cycle times
- Seal / Bearing Kits available

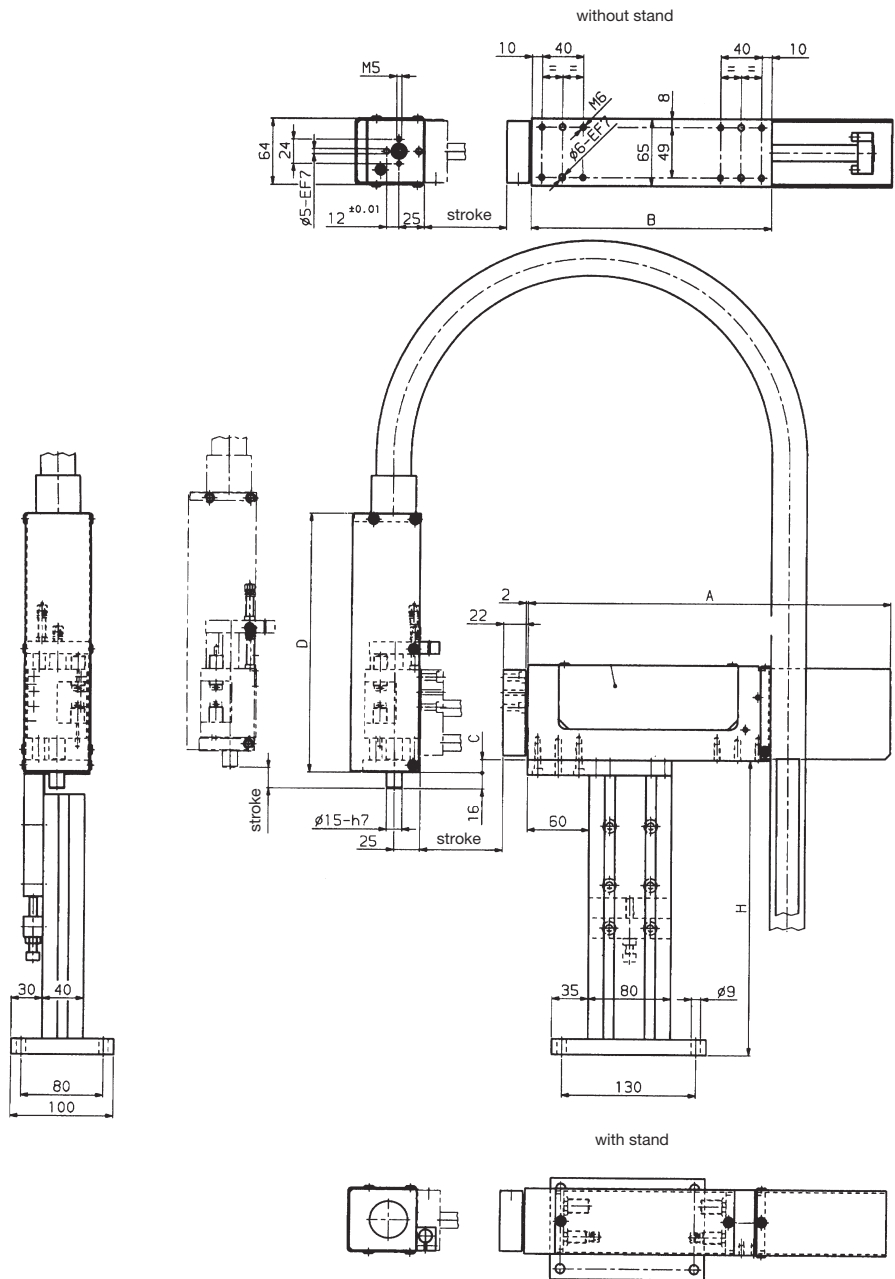

Linear Unit			Vertical Unit		
Stroke	A	B	Stroke	C	D
100+	352	234	20*	13	251.5
150+	452	284	50*	73	311.5
200+	552	334	80*	133	371.5

H=Height (adjustable +/- 20 mm)

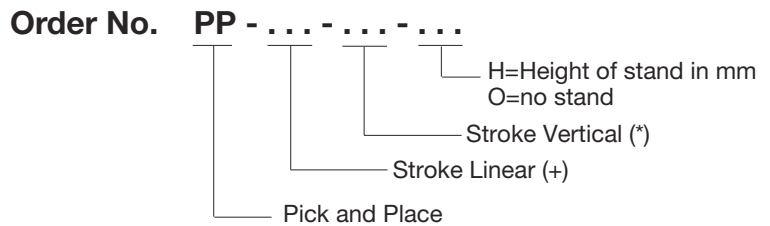

## ELECTRIC LINEAR ACTUATORS

SECTION 2

**meto-fer®**  
**automation**

Your complete source for industrial automation and electronics

**mf automation, inc.**

[www.meto-fer.com](http://www.meto-fer.com)

1-888-638-6337

# Linear Unit LM-26-RW Type S

Ball Screw, Twin Rail Positioning (Zero Backlash)

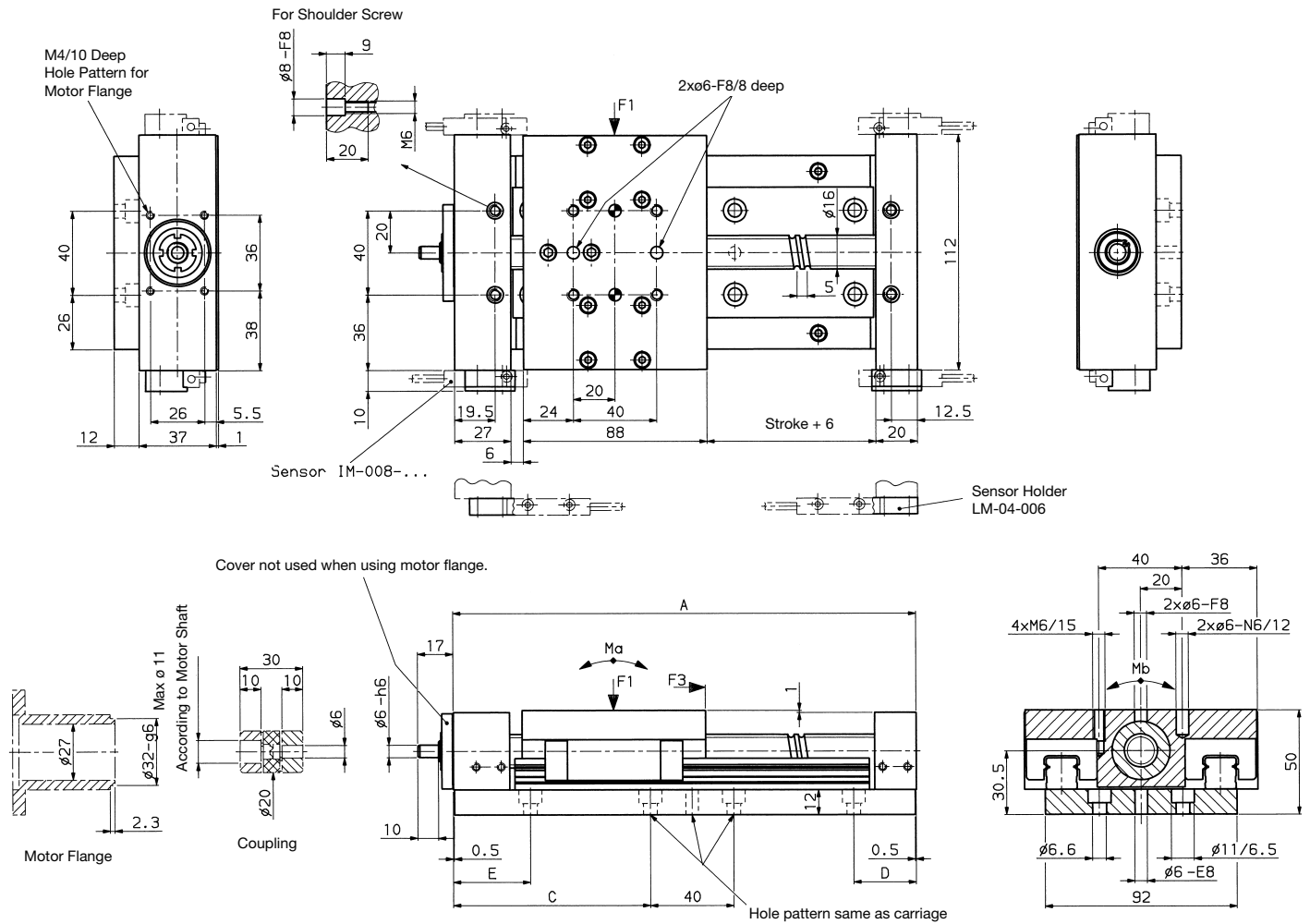

Stroke	A	C	D	E	F1 [N] (stat./dyn.)	F3 [N]	Ma [Nm]	Mb [Nm]	Weight [lb] (kg)
0-50	197	82	35	42	750	*	30	30	8.3 (3.8)
0-75	222	95	30	37	750	*	30	30	9.0 (4.1)
0-100	247	107	30	37	750	*	30	30	9.7 (4.4)
0-150	297	132	30	37	750	*	30	30	11.0 (5.0)
0-200	347	157	30	37	750	*	30	30	12.3 (5.6)
0-250	397	182	30	37	750	*	30	30	13.6 (6.2)
0-300	447	207	30	37	750	*	30	30	15.2 (6.9)
0-400	547	257	30	37	750	*	30	30	17.8 (8.1)

\*see back page

## Order No. LM26RW-5-...-S

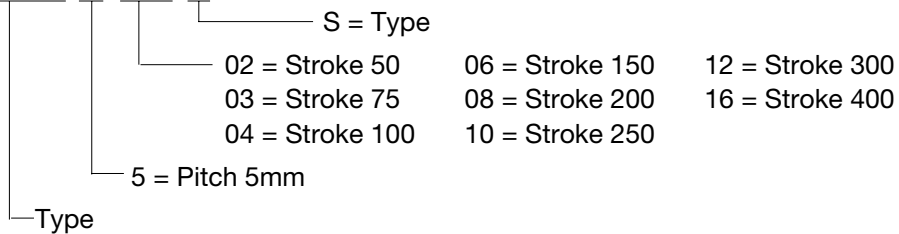

**Note:** Sensors, Flange and Coupling need to be ordered separately. See back page.



# Linear Unit LM-26-RW Type S

Ball Screw, Twin Rail Positioning (Zero Backlash)

**Sensor:** IM-008-NS-U2L (NPN)  
IM-008-PS-U2L (PNP)

Additional sensor and cables may be found in the Sensor Catalog.

## Motor Flange:

The motor flange is mounted with four M4 screws and serves simultaneously to secure the double race thrust bearing. Standard flanges are available for stepper motors as accessories. Flanges for DC-Motors are manufactured upon request. Please include a sketch of the desired motor pattern.

**Order No.** Motor Flange for LM-26-RW

## Coupling:

It is recommended to mount a high torque flex coupling between motor and unit.

**Order No.** Coupling for LM-26-RW Motor shaft  $\varnothing$  . . . mm

## Inertial mass "J"

The listed inertial mass "J" reflects the entire unit including the coupling (motor not included).

At a stroke of 25mm:  $J = 0.30 \text{ kgcm}^2$

J increases per additional 25mm stroke by  $0.012 \text{ kgcm}^2$

## F5 is dependent upon motor torque Md:

$$\text{By pitch 5mm: } \frac{Md [\text{Ncm}]}{0.08} = N \quad \text{max. allowed 1000 N}$$

## Ball Screw:

Rolled ball screw, ISO Class 7 (DIN 69051)

Zero clearance ball screw nut

## Bearing of the Ball Screw:

Precision ball bearing, axial play = 0.007 - 0.024mm.

## The units can be used as X-Y Tables:

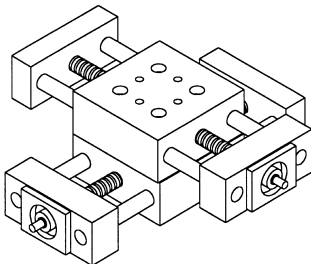

# Linear Unit LM-60-RW

Ball Screw (anti-backlash), Twin Rail

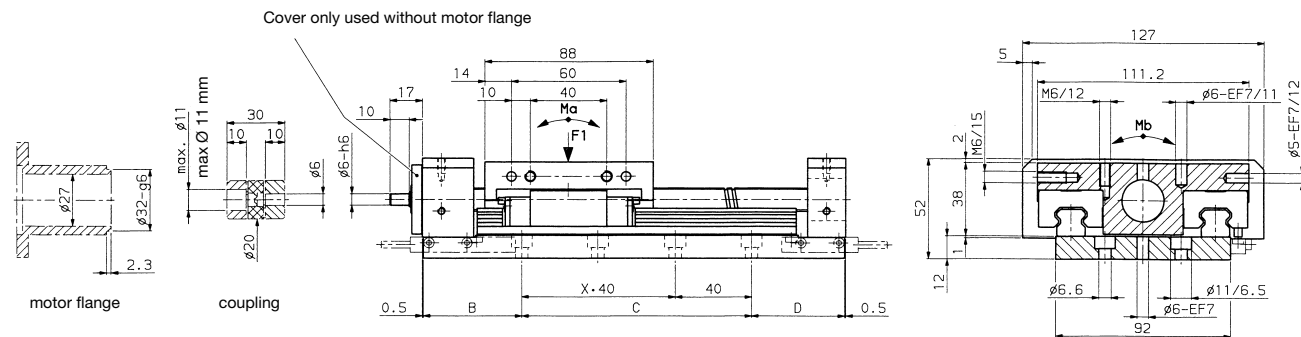
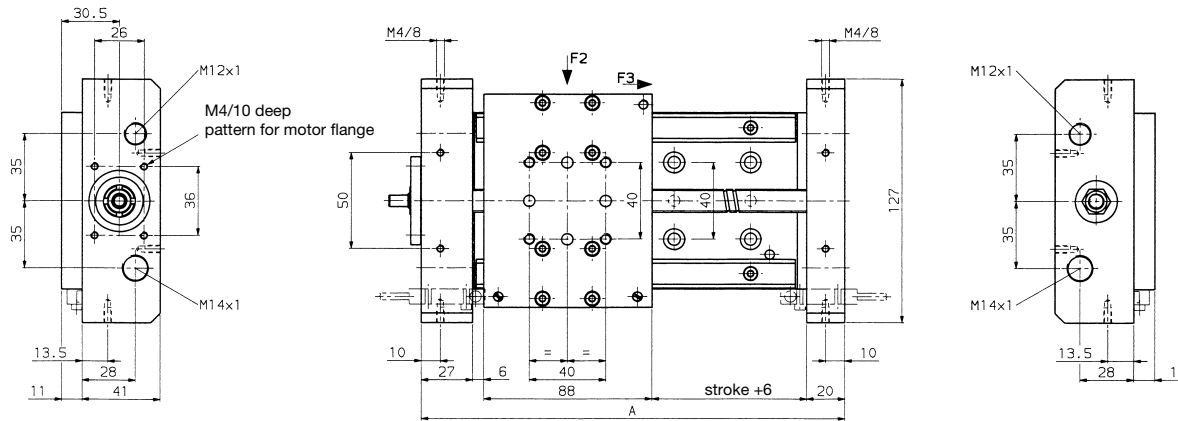
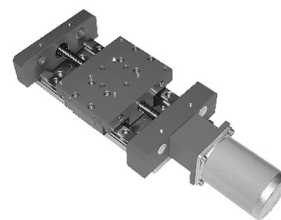

Stroke mm	A mm	B mm	C mm	D mm	X mm	F1 lb (N)	F2 lb (N)	F3 lb (N)	Ma lb. in (Nm)	Mb lb. in (Nm)	Weight lb. (kg)
0-50	197	39.5	120	36.5	2	168 (750)	112 (500)	*	265 (30)	265 (30)	8.3 (3.8)
0-75	222	52.0	120	49.0	2	168 (750)	112 (500)	*	265 (30)	265 (30)	9.0 (4.1)
0-100	247	64.5	120	61.5	2	168 (750)	112 (500)	*	265 (30)	265 (30)	9.7 (4.4)
0-150	297	89.5	120	86.5	2	168 (750)	112 (500)	*	265 (30)	265 (30)	11.0 (5.0)
0-200	347	74.5	200	71.5	4	168 (750)	112 (500)	*	265 (30)	265 (30)	12.3 (5.6)
0-250	397	99.5	200	96.5	4	168 (750)	112 (500)	*	265 (30)	265 (30)	13.6 (6.2)
0-300	447	124.5	200	121.5	4	168 (750)	112 (500)	*	265 (30)	265 (30)	15.2 (6.9)
0-400	547	174.5	200	171.5	4	168 (750)	112 (500)	*	265 (30)	265 (30)	17.8 (8.1)

\*see back page

Order No. **LM-60-RW-5-...**

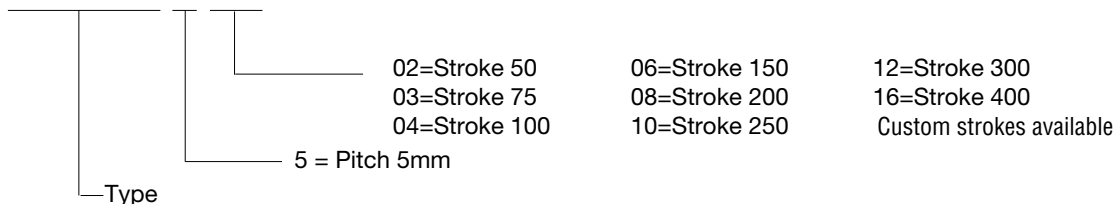

**Note:** Sensors, Flange, and Coupling need to be ordered separately-see back page.

# Linear Unit LM-60-RW

Ball Screw, Twin Rail

**Sensor Order No.** IM-008-NS-U2L (NPN)  
IM-008-PS-U2L (PNP)

Additional sensor and cables may be found in the Sensor Catalog.

## Motor Flange:

The motor flange is mounted with M4 screws and secures the bearing. Standard flanges are available. Please include a sketch of desired motor pattern.

**Order No.** Motor Flange for LM-26-60-RW

## Coupling:

It is recommended to use a high torque flex coupling.

**Order No.** Coupling for LM-26-60-RW Motor shaft  $\varnothing$  . . . mm

## Inertial mass "J"

The listed inertial mass "J" reflects the entire unit including the coupling (motor not included).

At a stroke of 25mm:  $J = 0.23 \text{ kgcm}^2$

J increases per additional 25mm stroke by  $0.005 \text{ kgcm}^2$

## F5 is dependent upon motor torque Md:

$$\text{By pitch 5mm: } \frac{Md [\text{Ncm}]}{0.08} = N \quad \text{max. allowed 1000 N}$$

## Ball Screw:

Rolled ball screw, ISO Class 7 (DIN 69051)

Ball screw nut (anti-backlash)

## Ball Screw Bearing:

Precision ball bearing, axial play = 0

## The units can be used as X-Y Tables:

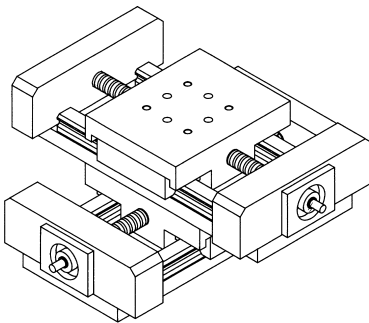

Easy mounting with the following units:

**LMP-60**  
**LMP-60A**  
**LM-60-RW**  
**LM-60-RWA**

# Linear Unit LM-60-RWA

Ball Screw (anti-backlash), Twin Rail, with cover

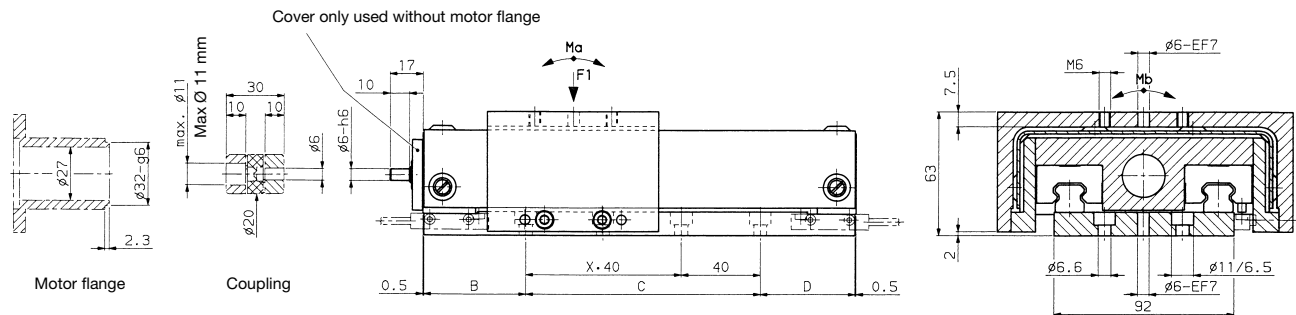
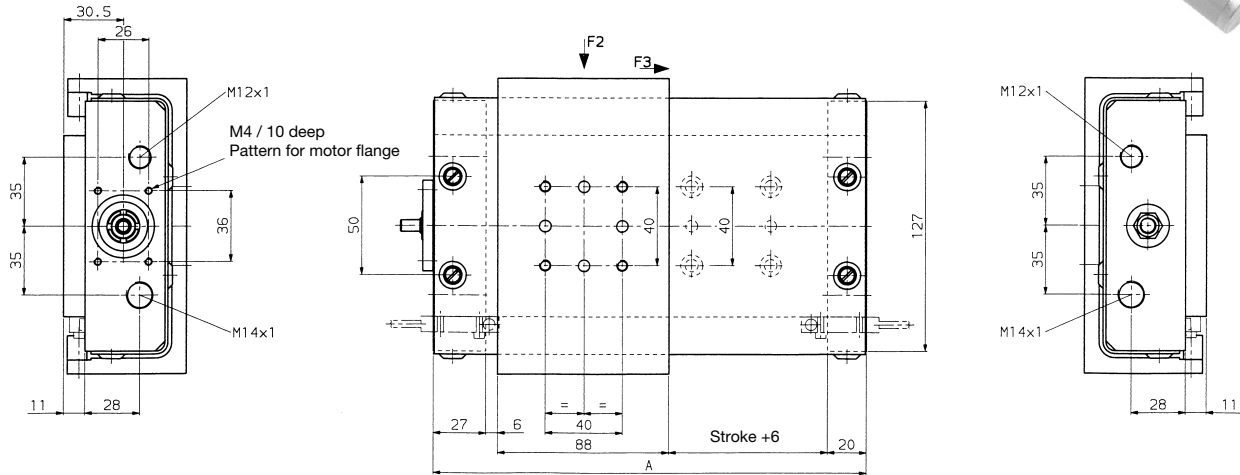
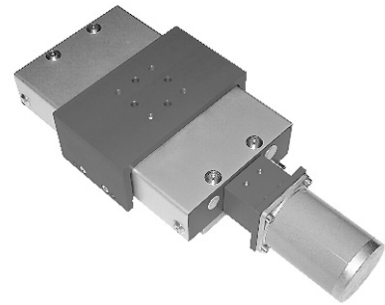

Stroke mm	A mm	B mm	C mm	D mm	X m	F1 lb (N)	F2 lb (N)	F3 lb (N)	Ma lb. In (Nm)	Mb lb. In (Nm)	Weight lb. (kg)
0-50	197	39.5	120	36.5	2	168 (750)	112 (500)	*	265 (30)	265 (30)	11.0 (5.0)
0-75	222	52.0	120	49.0	2	168 (750)	112 (500)	*	265 (30)	265 (30)	11.6 (5.3)
0-100	247	64.5	120	61.5	2	168 (750)	112 (500)	*	265 (30)	265 (30)	12.3 (5.6)
0-150	297	89.5	120	86.5	2	168 (750)	112 (500)	*	265 (30)	265 (30)	13.8 (6.3)
0-200	347	74.5	200	71.5	4	168 (750)	112 (500)	*	265 (30)	265 (30)	15.2 (6.9)
0-250	397	99.5	200	96.5	4	168 (750)	112 (500)	*	265 (30)	265 (30)	16.5 (7.5)
0-300	447	124.5	200	121.5	4	168 (750)	112 (500)	*	265 (30)	265 (30)	18.3 (8.3)
0-400	547	174.5	200	171.5	4	168 (750)	112 (500)	*	265 (30)	265 (30)	21.1 (9.6)

\*see back page

Order No. **LM-60-RWA-5-...**

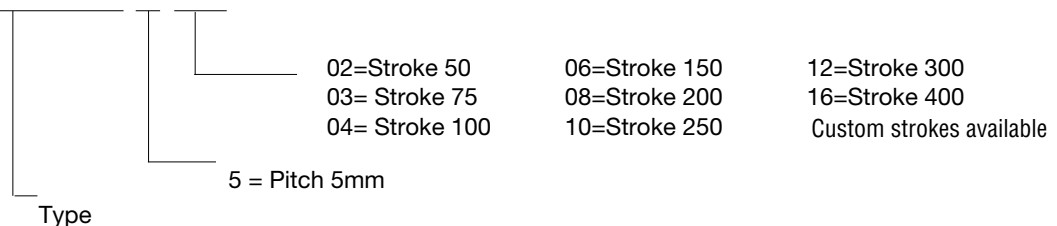

**Note:** Sensors, Flange, and Coupling need to be ordered separately-see back page.

# Linear Unit LM-60-RWA

Ball Screw, Twin Rail, with cover

**Sensor Order No.** IM-008-NS-U2L (NPN)  
IM-008-PS-U2L (PNP)

Additional sensors and cables may be found in the Sensor Catalog.

## Motor Flange:

The motor flange is mounted with M4 screws and also secures the bearing. Standard flanges are available. Please include a sketch of the desired motor pattern.

**Order No.** Motor Flange for LM-60-RWA

## Coupling:

It is recommended to use a high torque flex coupling between motor and LM.

**Order No.** Coupling for LM-60-RWA Motor shaft  $\varnothing$  . . . mm

## Inertial mass "J"

The listed inertial mass "J" reflects the entire unit including the coupling (motor not included).

At a stroke of 25mm:  $J = 0.23 \text{ kgcm}^2$

J increases per additional 25mm stroke by  $0.005 \text{ kgcm}^2$

## F5 is dependent upon motor torque Md:

$$\text{By pitch 5mm: } \frac{Md [\text{Ncm}]}{0.08} = N \quad \text{max. allowed 1000 N}$$

## Ball Screw:

Rolled ball screw, ISO Class 7 (DIN 69051)

Ball screw nut (anti-backlash)

## Ball Screw Bearing:

Precision ball bearing, axial play = 0

## The units can be used as X-Y Tables:

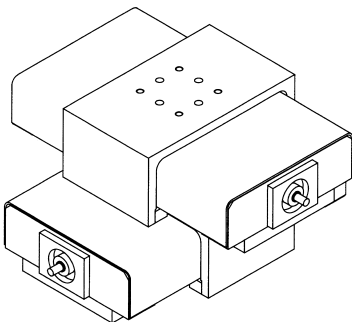

Easy mounting with the following units:

**LMP-60**  
**LMP-60A**  
**LM-60-RW**  
**LM-60-RWA**

# Linear Unit LK 100-RW

Ball Screw (anti-backlash), Twin Rail, with cover

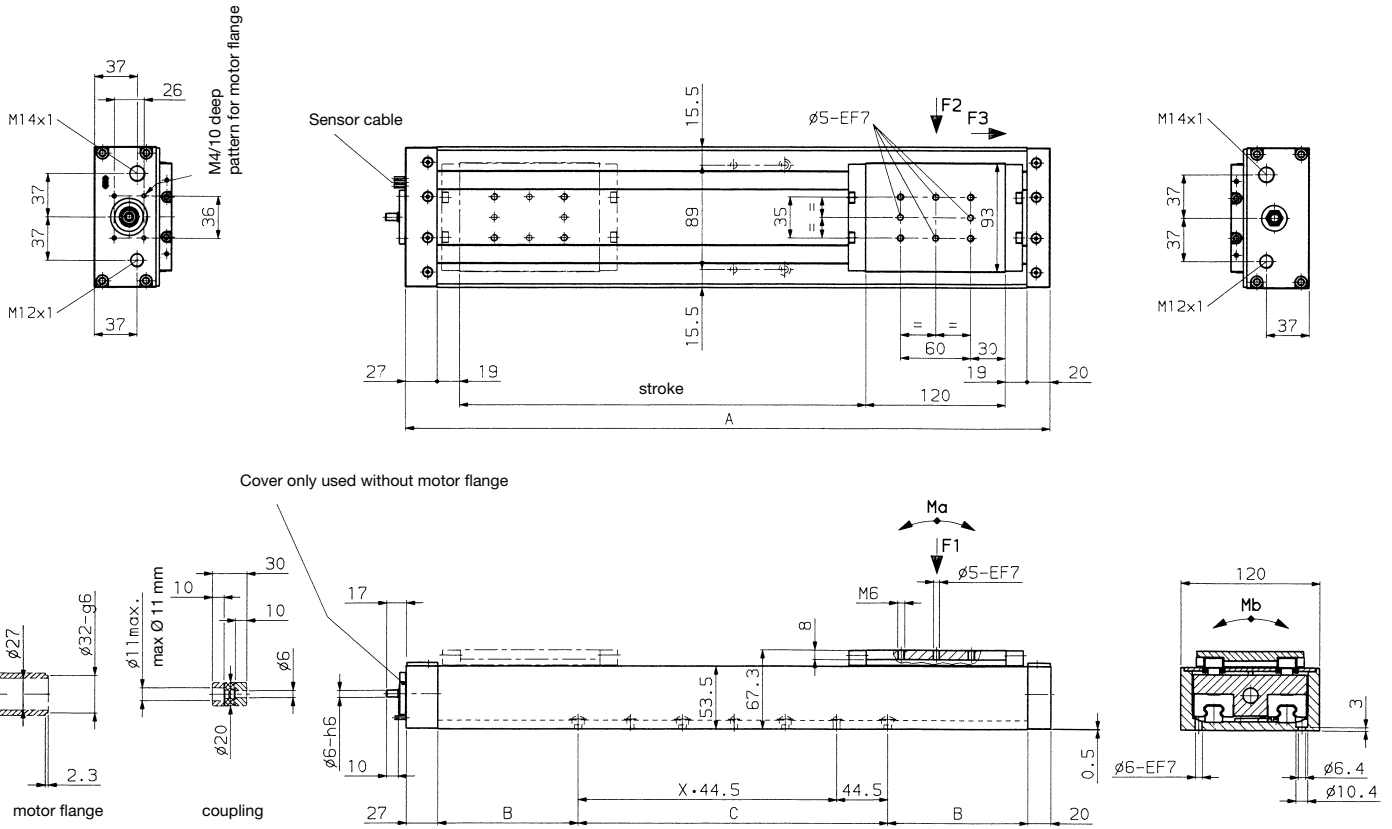

Stroke mm	A mm	B mm	C mm	X mm	F1 lb (N)	F2 lb (N)	F3 lb (N)	Ma lb. In (Nm)	Mb lb. In (Nm)	Weight lb. (kg)
0-200	405	134.5	89	1	168 (750)	112 (500)	*	265 (30)	265 (30)	17.6 (8.0)
0-250	455	70.5	267	5	168 (750)	112 (500)	*	265 (30)	265 (30)	18.7 (8.5)
0-300	505	95.5	267	5	168 (750)	112 (500)	*	265 (30)	265 (30)	19.8 (9.0)
0-350	555	120.5	267	5	168 (750)	112 (500)	*	265 (30)	265 (30)	20.9 (9.5)
0-400	605	145.5	267	5	168 (750)	112 (500)	*	265 (30)	265 (30)	21.8 (9.9)
0-500	705	195.5	267	5	168 (750)	112 (500)	*	265 (30)	265 (30)	24.0 (10.9)
0-600	805	245.5	267	5	146 (650)	89 (400)	*	265 (30)	265 (30)	26.0 (11.8)
0-800	1005	345.5	267	5	146 (650)	89 (400)	*	265 (30)	265 (30)	29.1 (13.2)
0-1000	1205	445.5	267	5	146 (650)	89 (400)	*	265 (30)	265 (30)	34.3 (15.6)

\*see back page

## Order No. LK-100-RW-5- ...

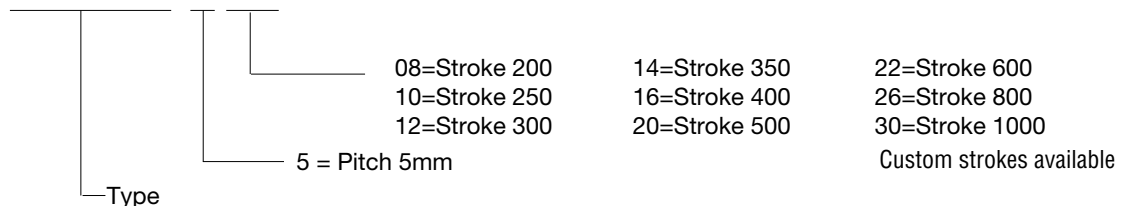

**Note:** Sensors, Flange, and Coupling need to be ordered separately-see back page.

# Linear Unit LK 100-RW

Ball Screw, Twin Rail, with cover

**Sensor Order No.** IM-008-NS-U2L (NPN)  
IM-008-PS-U2L (PNP)

Additional sensor and cables may be found in the Sensor Catalog.

## Motor Flange:

The motor flange is mounted with M4 screws and also secures the bearing. Standard flanges are available. Please include a sketch of desired motor pattern.

**Order No.** Motor Flange for LK-100-RW

## Coupling:

It is recommended to use a high torque flex coupling.

**Order No.** Coupling for LK-100-RW Motor shaft  $\varnothing$  . . . mm

## Inertial mass "J"

The listed inertial mass "J" reflects the entire unit including the coupling (motor not included).

At a stroke of 25mm:  $J = 0.23 \text{ kgcm}^2$

J increases per additional 25mm stroke by  $0.005 \text{ kgcm}^2$

## F3 is dependent upon motor torque Md:

$$\text{By pitch 5mm: } \frac{Md [\text{Ncm}]}{0.08} = N \quad \text{max. allowed 1000 N}$$

## Ball Screw:

Rolled ball screw, ISO Class 7 (DIN 69051)

Ball screw nut (anti-backlash)

## Ball Screw Bearing:

Precision ball bearing, axial play = 0

# Linear Unit LK-100-RWA

Ball Screw (anti-backlash), Twin Rail

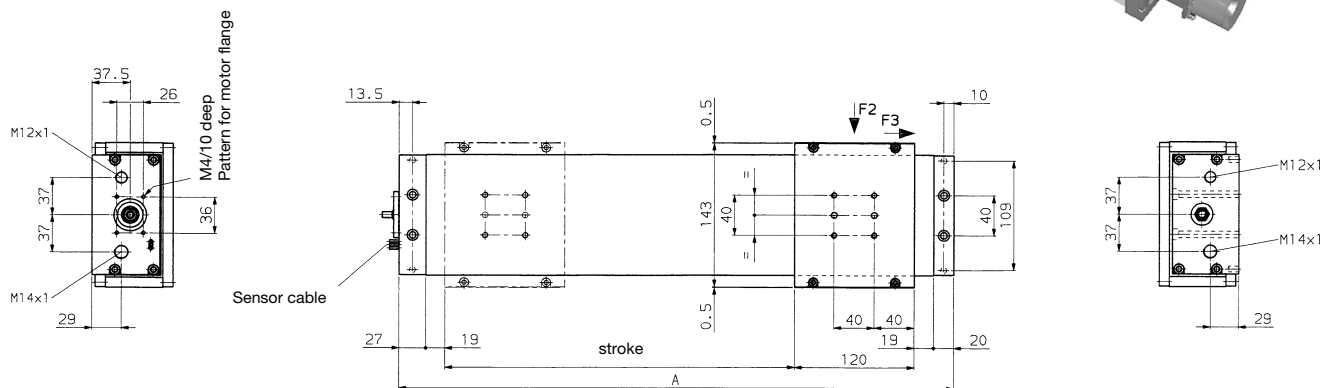
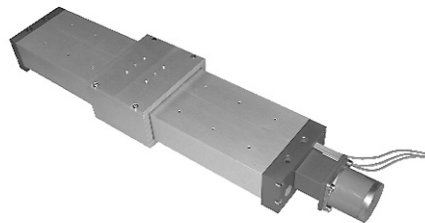

Cover only used without motor flange

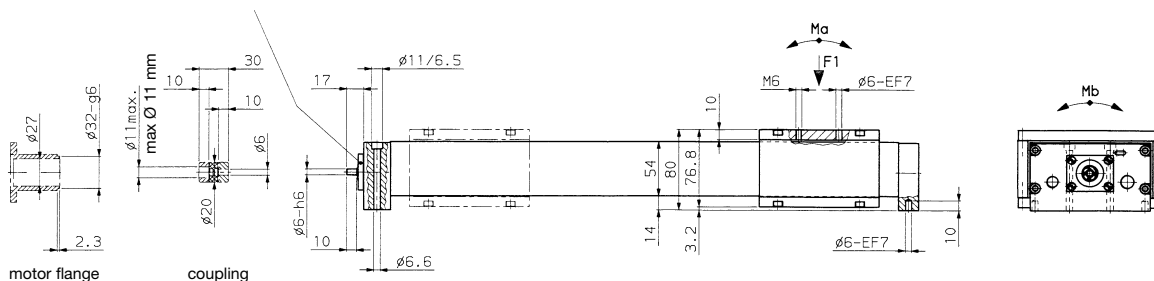

Stroke mm	A mm	F1 lb (N)	F2 lb (N)	F3 lb (N)	Ma lb. In (Nm)	Mb lb. In (Nm)	Weight lb. (kg)
0-200	405	168 (750)	112 (500)	*	265 (30)	265 (30)	16.5 (7.5)
0-250	455	168 (750)	112 (500)	*	265 (30)	265 (30)	17.4 (7.9)
0-300	505	168 (750)	112 (500)	*	265 (30)	265 (30)	18.5 (8.4)
0-350	555	168 (750)	112 (500)	*	265 (30)	265 (30)	19.4 (8.8)
0-400	605	168 (750)	112 (500)	*	265 (30)	265 (30)	20.2 (9.2)
0-500	705	168 (750)	112 (500)	*	265 (30)	265 (30)	22.2 (10.1)
0-600	805	146 (650)	89 (400)	*	265 (30)	265 (30)	24.2 (11.0)
0-800	1005	146 (650)	89 (400)	*	265 (30)	265 (30)	26.9 (12.2)
0-1000	1205	146 (650)	89 (400)	*	265 (30)	265 (30)	31.9 (14.5)

\*see back page

## Order No. LK-100-RWA-5-...

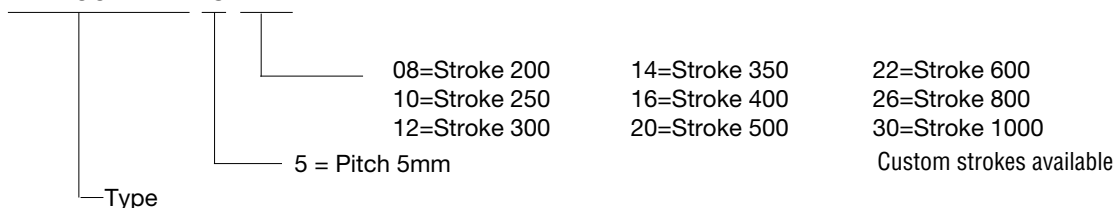

**Note:** Sensors, Flange, and Coupling need to be ordered separately-see back page.



# Linear Unit LK-100-RWA

Ball Screw, Twin Rail

**Sensor Order No.** IM-008-NS-U2L (NPN)  
IM-008-PS-U2L (PNP)

Additional sensor and cables may be found in the Sensor Catalog.

## Motor Flange:

The motor flange is mounted with M4 screws and also secures the double race thrust bearing. Standard flanges are available. Please include a sketch of desired motor pattern.

**Order No.** Motor Flange for LK-100-RWA

## Coupling:

It is recommended to use a high torque flex coupling.

**Order No.** Coupling for LK-100-RWA Motor shaft  $\varnothing$  . . . mm

## Inertial mass "J"

The listed inertial mass "J" reflects the entire unit including the coupling (motor not included).

At a stroke of 25mm:  $J = 0.23 \text{ kgcm}^2$

J increases per additional 25mm stroke by  $0.005 \text{ kgcm}^2$

## F5 is dependent upon motor torque Md:

$$\text{By pitch 5mm: } \frac{Md [\text{Ncm}]}{0.08} = N \quad \text{max. allowed 1000 N}$$

## Ball Screw:

Rolled ball screw, ISO Class 7 (DIN 69051)

Ball screw nut (anti-backlash)

## Ball Screw Bearing:

Precision ball bearing, axial play = 0

# Linear Unit LK-120-ZR

Timing Belt, Twin Rail

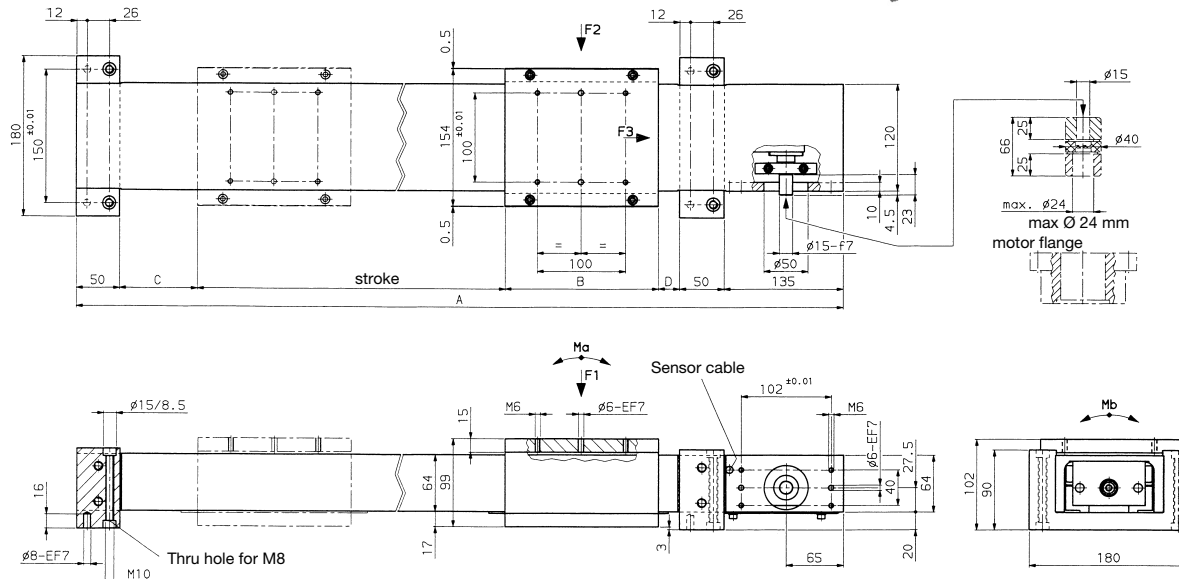
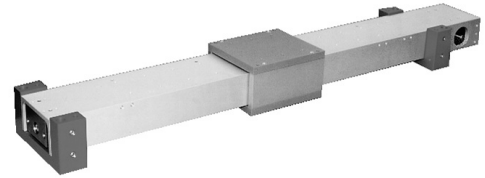

## LK-120-ZR-2 (with 2 carriages)

Stroke mm	A mm	B mm	C mm	D mm	F1 lb (N)	F2 lb (N)	F3 lb (N)	Ma lb. In (Nm)	Mb lb. In (Nm)	Weight lb. (kg)
0-250	772	175	88	24	168 (750)	112 (500)	*	265 (30)	265 (30)	37.0 (16.8)
0-500	1022	175	88	24	168 (750)	112 (500)	*	265 (30)	265 (30)	42.5 (19.3)
0-750	1272	175	88	24	146 (650)	90 (400)	*	265 (30)	265 (30)	48.2 (21.9)
0-1000	1522	175	88	24	146 (650)	90 (400)	*	265 (30)	265 (30)	53.8 (24.4)
0-1250	1722	175	88	24	134 (600)	78 (350)	*	265 (30)	265 (30)	58.8 (26.7)
0-1500	2022	175	88	24	123 (550)	67 (300)	*	265 (30)	265 (30)	65.0 (29.5)
0-2000	2522	175	88	24	112 (500)	56 (250)	*	265 (30)	265 (30)	76.2 (34.6)
0-2500	3022	175	88	24	101 (450)	45 (200)	*	265 (30)	265 (30)	87.5 (39.7)

## LK-120-ZR-4 (with 4 carriages)

Stroke mm	A mm	B mm	C mm	D mm	F1 lb (N)	F2 lb (N)	F3 lb (N)	Ma lb. In (Nm)	Mb lb. In (Nm)	Weight lb. (kg)
0-250	832	220	95.5	31.5	303(1350)	202 (900)	*	486 (55)	486 (55)	41.2 (18.7)
0-500	1082	220	95.5	31.5	303(1350)	202 (900)	*	486 (55)	486 (55)	46.7 (21.2)
0-750	1332	220	95.5	31.5	269(1200)	157 (700)	*	486 (55)	486 (55)	52.4 (23.8)
0-1000	1582	220	95.5	31.5	269(1200)	157 (700)	*	486 (55)	486 (55)	57.9 (26.3)
0-1250	1782	220	95.5	31.5	224(1000)	146 (650)	*	486 (55)	486 (55)	63.7 (28.9)
0-1500	2082	220	95.5	31.5	224(1000)	123 (550)	*	486 (55)	486 (55)	69.2 (31.4)
0-2000	2582	220	95.5	31.5	20(900)	101 (450)	*	486 (55)	486 (55)	80.4 (36.5)
0-2500	3082	220	95.5	31.5	180(800)	78 (350)	*	486 (55)	486 (55)	91.7 (41.6)

\*see back page

## Order No. LK-120-ZR-...-...

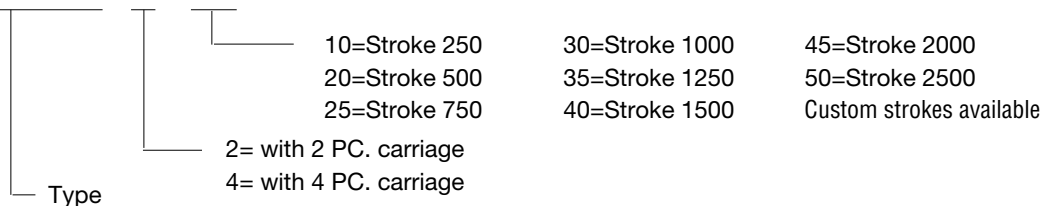

**Note:** Sensors, Flange, and Coupling need to be ordered separately-see back page.

# Linear Unit LK-120-ZR

Timing Belt, Twin Rail

**Sensor Order No.**                    IM-008-NS-U2L (NPN)  
    IM-008-PS-U2L (PNP)

Please find additional information in our Electronic Catalog.

## Motor Flange:

The motor flange is mounted with M6 screws. To manufacture the flange please include drawing of motor pattern.

**Order No.**            Motor Flange for LK-120-ZR

## Coupling:

It is recommended to use a high torque flex coupling.

**Order No.**            Coupling for LK-120-ZR            Motor shaft  $\varnothing$  . . . mm

## Timing Belt:

Pitch 5 mm, drive gear 25 teeth, division  $\varnothing=39.78$  mm, stroke per turn=125 mm

**F3 is dependent upon motor torque Md:**

$$F3 = \frac{Md \text{ [Ncm]}}{1.989} = N \quad \text{max. allowed 2,660 N}$$

# Linear Unit LK 160-ZR

Electric Linear Actuator with timing belt

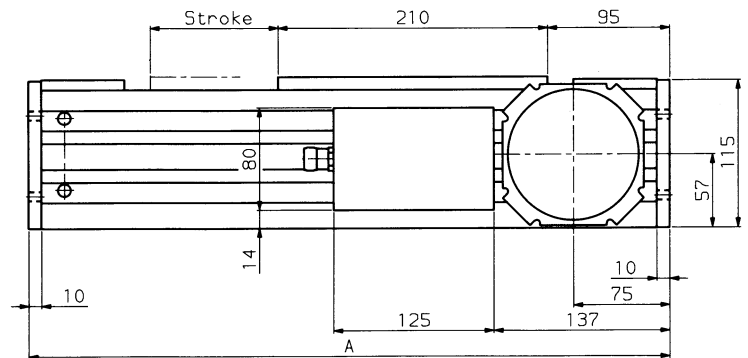
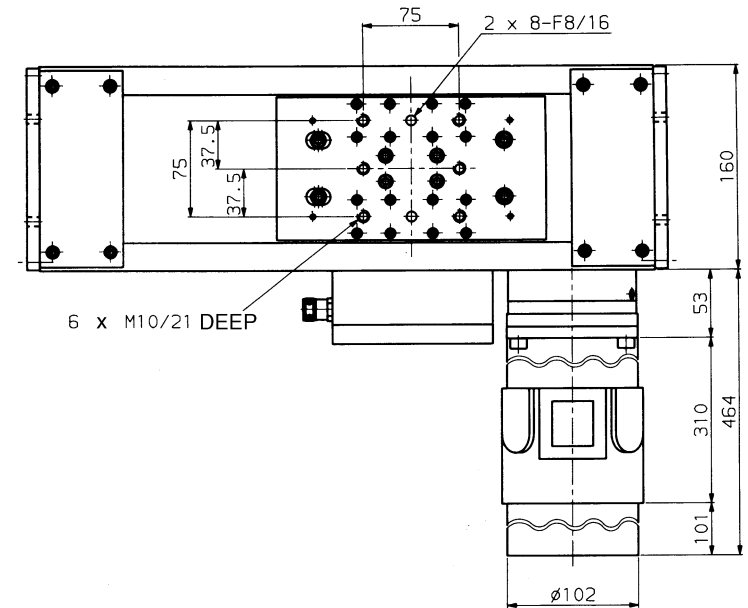
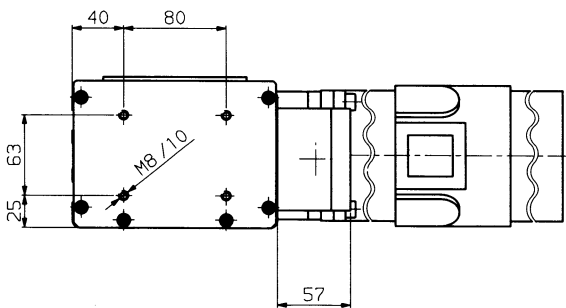
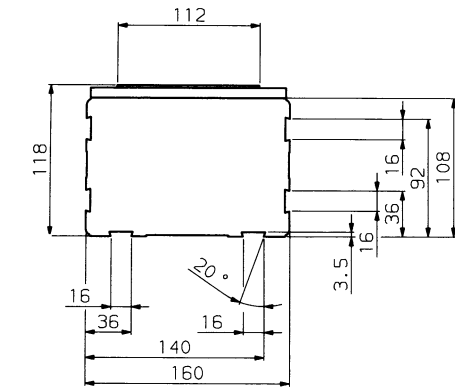

Type	Stroke	A	Weight <sup>1</sup>
LK160-ZR-03	0- 300	700	55.1 lb (25.0 kg)
LK160-ZR-04	0- 400	800	60.6 lb (27.5 kg)
LK160-ZR-05	0- 500	900	66.2 lb (30.0 kg)
LK160-ZR-06	0- 600	1000	71.7 lb (32.5 kg)
LK160-ZR-07	0- 700	1100	77.2 lb (35.0 kg)
LK160-ZR-08	0- 800	1200	82.7 lb (37.5 kg)
LK160-ZR-09	0- 900	1300	88.2 lb (40.0 kg)
LK160-ZR-10	0-1000	1400	93.7 lb (42.5 kg)
LK160-ZR-12	0-1200	1600	104.7 lb (47.5 kg)
LK160-ZR-14	0-1400	1800	115.8 lb (52.5 kg)
LK160-ZR-16	0-1600	2000	126.8 lb (57.5 kg)

<sup>1</sup> Without Motor

## Technical data:

- Timing belt drive
- Self supporting solid Aluminum extrusion
- High load capacity as a result of ball bearings on hardened guide rails
- High speed up to 2.5 m/sec (98.4"/sec)
- High repeatability 0.05 mm (.002")
- High resolution 0.05 mm (.002")
- High cycle rate: The standard motor can be loaded up to 9 Nm (79.65 lb. in) in start-stop cycling when using forced ventilation
- Overtravel switches in both end positions, plus mechanical shock absorbers
- Home position switch
- Easy mounting due to dovetail groove in extrusion
- Stroke per turn 125 mm

## Order No.

LK 160 - ZR - ... - ...

O = Without motor  
M = With DC motor

Typ

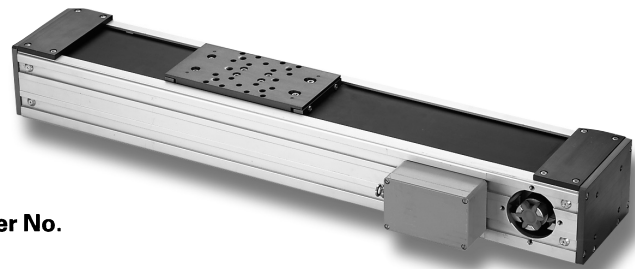

## Max. controllable load parameters

Max. load with acceleration referred to a constant torque of 6Nm (53.1 lb.in)

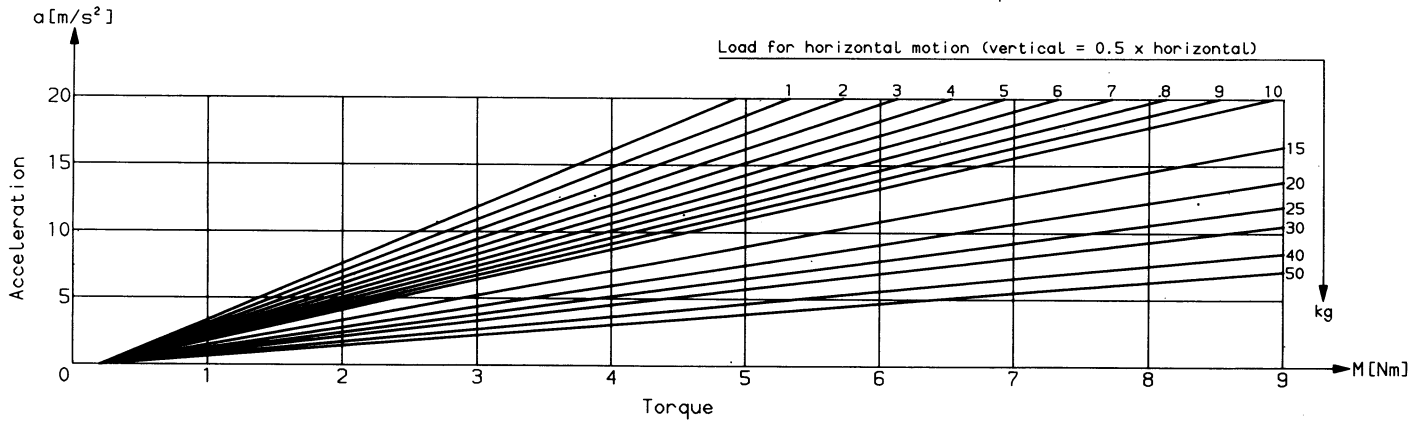

## Acceleration time/deceleration time

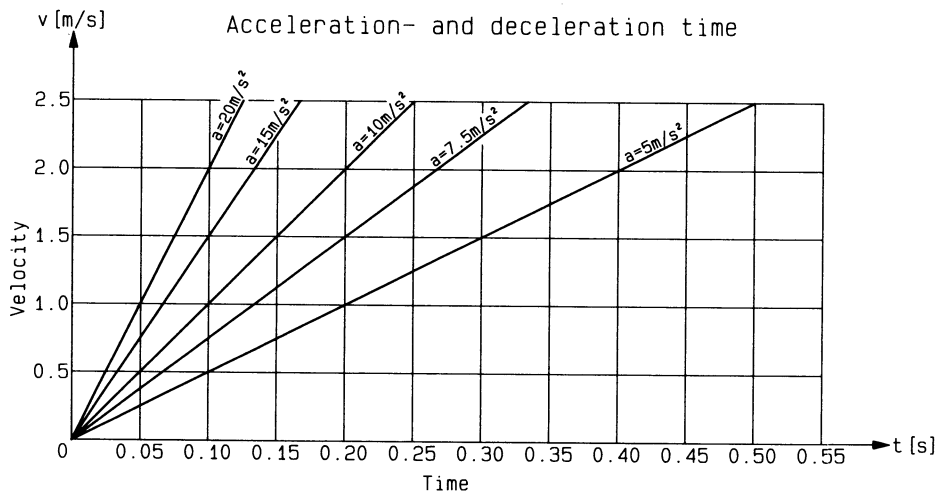

## Acceleration distance/deceleration distance

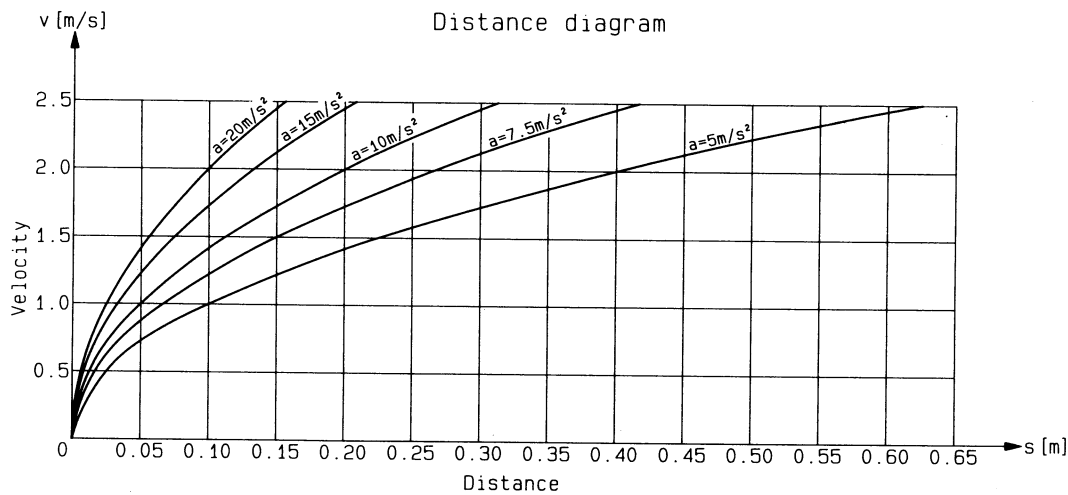

### Dynamic mechanical load capacity for 5000 km (1000 km)

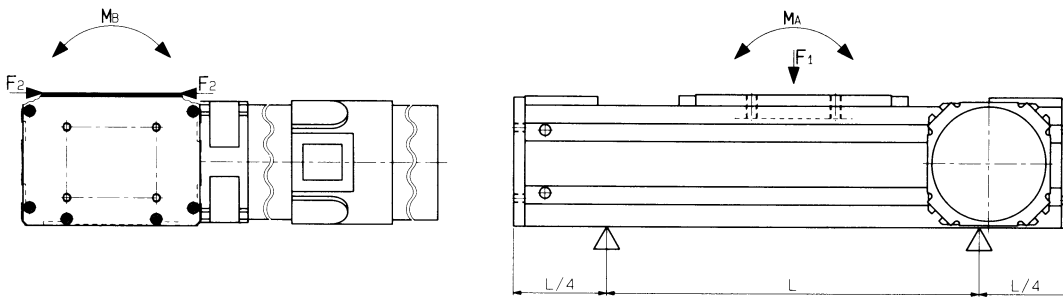

$F_1 = 1500 \text{ N (2590 N)}$   
 $F_2 = 1500 \text{ N (2590 N)}$

$M_A = 44 \text{ Nm (74 Nm)}$   
 $M_B = 57 \text{ Nm (98 Nm)}$

Deflection of carrier unit with ends supported  
 Deflection  $f < 0.2 \text{ mm (<.008" )}$  with  $F_1 = 1500 \text{ N (337.2 lb)}$   
 Support  $L = 1350 \text{ mm (53.15" )}$

### Mounting options

Option 1

- With clamps

Option 2

- Tapped mounting plate and through holes

Option 3

- Front mounting plate according to data sheet, sheet 2.091  
 - Combination: Front mounting and clamp

Option 4

- with key

OPTION 1

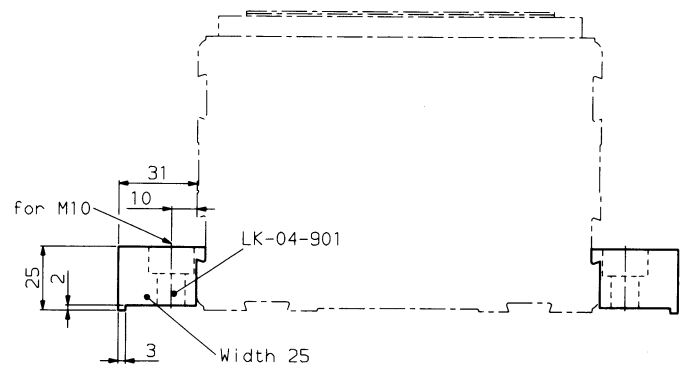

OPTION 2

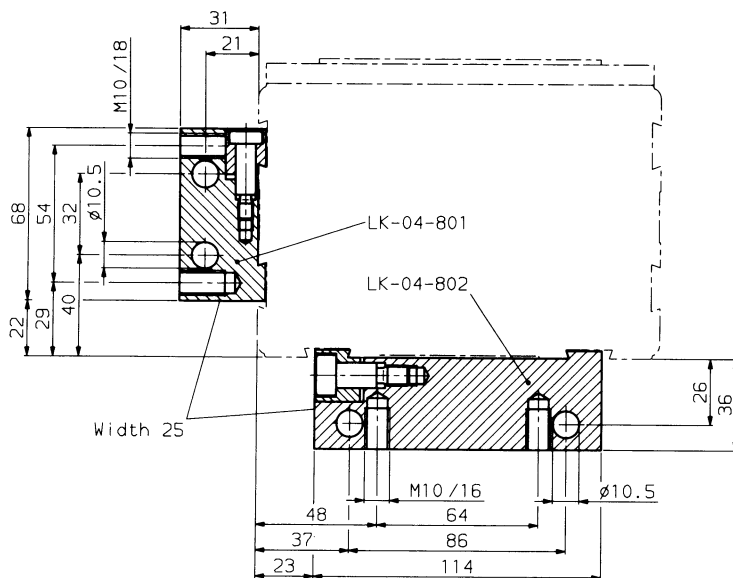

OPTION 3

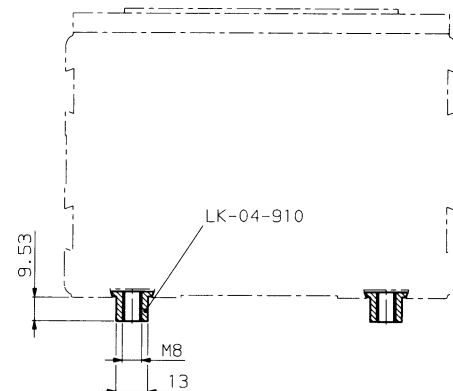

# Rotary indexing table RE 75

Electrical Actuator

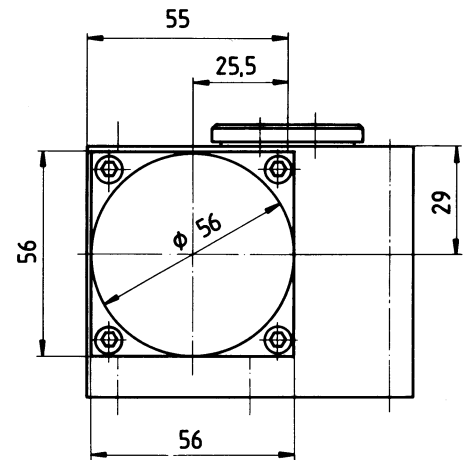
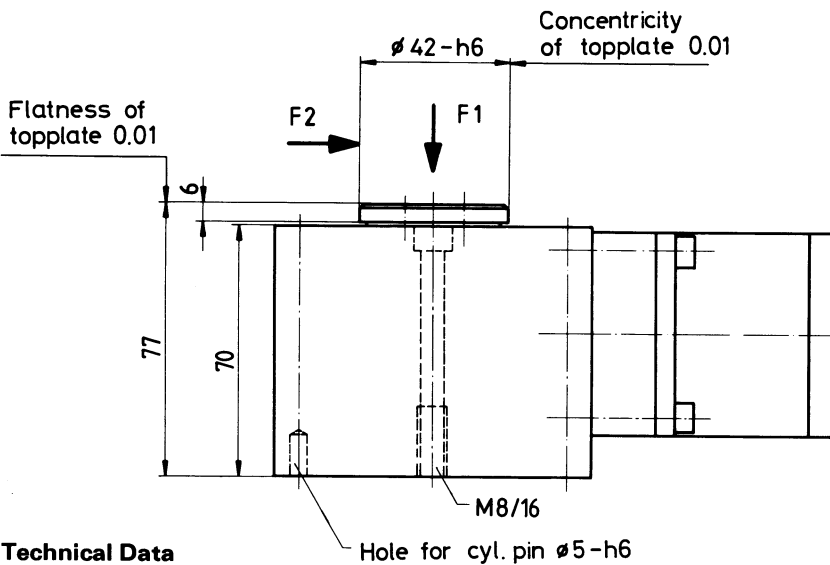
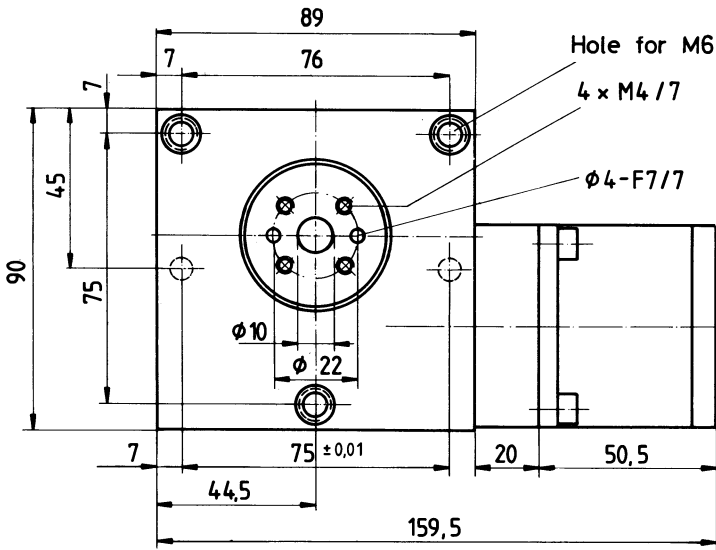

## Technical Data

Type of drive	Stepping motor	DC-motor
Procedural mode [°]	360	360
Travel per revolution of motor shaft [°]	24°	24°
Drive element	worm gear	worm gear
Transport load [lb (kg)]	110.3 (50)	110.3 (50)
Carrying power F1 dyn. [lb (N)]	124 (550)	124 (550)
Radial force F2 dyn. [lb (N)]	337 (1500)	337 (1500)
Dead weight		
Torque [lb. in (Nm)]	95.58 (10,8)	
Step angle [°]	0.9	
Starting frequency [cycles]	900	
Operating frequency [cycles]	4800	
Impulse generator [imp./rev.]		600
Motor revs. [rpm]	720	
Motor torque [lb. in (Nm)]	1.59 (0,18)	
Stopping momentum	self-locking	
Acceleration time [s]	0.1	
Rotating speed [%s]	60	
Resolution [']	45	30
Repeatability [']	45	30
Installation position	as desired	as desired
Weight (without motor) [lb (kg)]	5.1 (2,3)	5.1 (2,3)

## Order No.

RE 75 — ...

Type of drive: OM = Without motor  
SM = Stepping motor  
DC = DC-motor

## ROTARY ACTUATORS

SECTION 3

**meto-fer®**  
**automation**

Your complete source for industrial automation and electronics

**mf automation, inc.**

[www.meto-fer.com](http://www.meto-fer.com)

1-888-638-6337



# Rotary Actuators MD

- Features:**
- Backlash free
  - Ball bearings
  - External stops

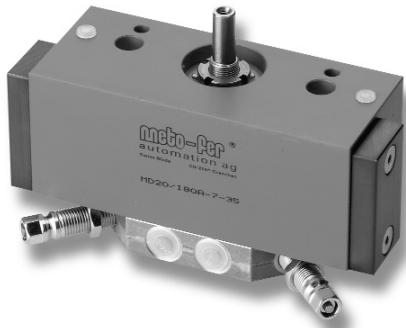

Model A (MD 20)

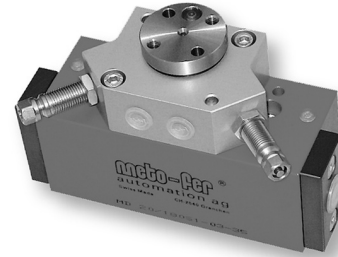

Model V (MD 20)



Model B (MD 12)

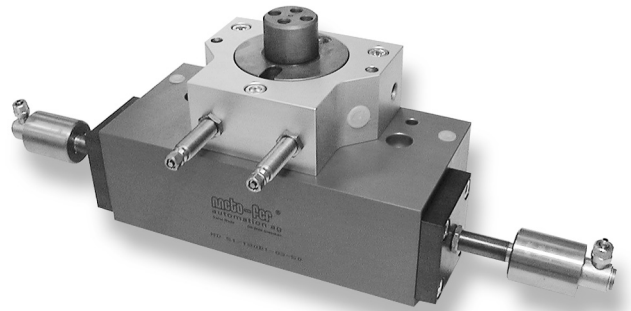

MD51 / 180B1, with oil cushion

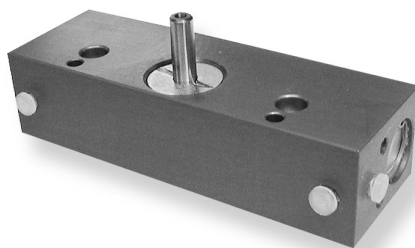

Model S (MD 12)

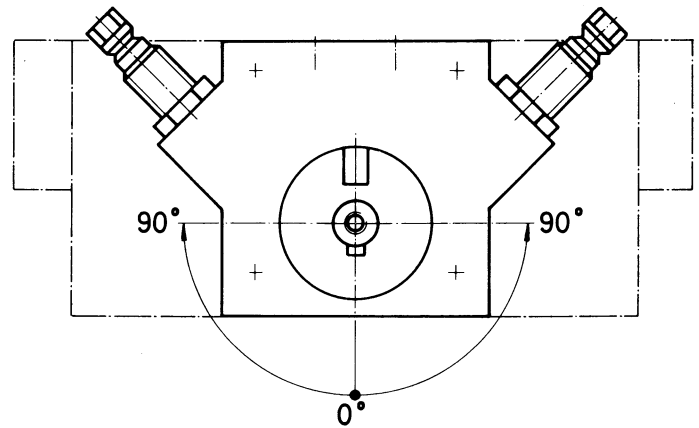

Position of the shaft by MD12, MD20, MD32

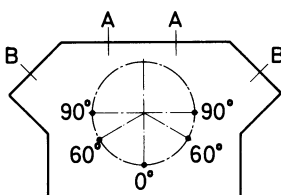

Position of the Stop screw by MD12, MD20, MD32

- Angle of rotation: 0 – 60° Stop screw in Pos. B  
 Angle of rotation: 60 – 90° Stop screw in Pos. A

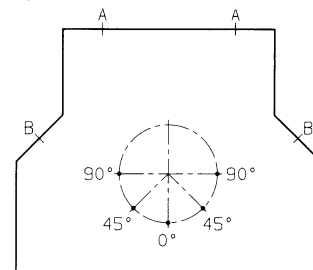

Position of the Stop screw by MD 51

- Angle of rotation: 0 - 45° Stop screw in Pos. A  
 Angle of rotation: 45 - 90° Stop screw in Pos. B

# Rotary Actuator MD 12

## Model S

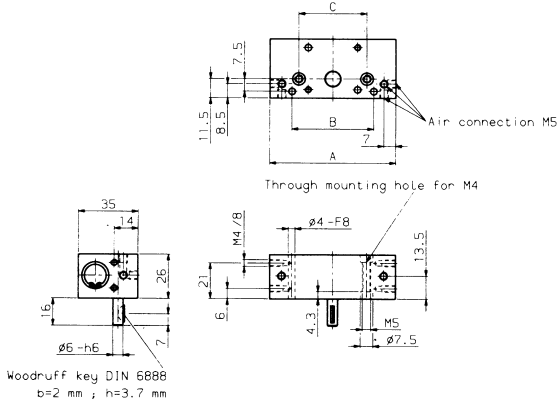

Type	A	B	C	Angle of rotation	Air consumption for each double stroke at 5 bar	Weight (lb (kg))
MD 12/ 90 S	74	48	40	90°	.001 scf (0.02 NL)	.55 (0.25)
MD 12/180 S	105	60	60	180°	.002 scf (0.04 NL)	.66 (0.30)

Max. load radial to shaft: 67 lb (300 N)  
 Max. load axial to shaft: 67 lb (300 N)  
 Torque at 72.5 psi (5 bar) : 3.36 lb.in (0.38 Nm)

Order No. MD 12/ 90 S  
 MD 12/180 S

## Model A

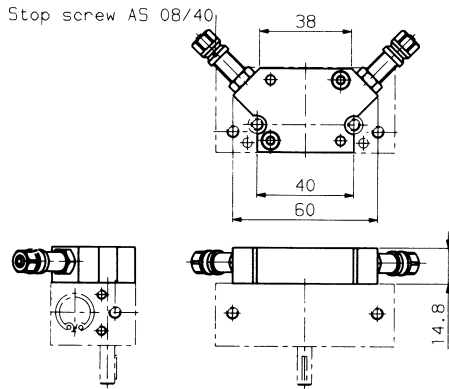

Type	Angle of rotation	Air consumption for each double stroke at 72.5 psi (5 bar)	Weight
MD 12/ 90 A	0 - 90°	.001 scf (0.02 NL)	.73 lb (0.33 kg)
MD 12/180 A	0 - 180°	.002 scf (0.04 NL)	.79 lb (0.36 kg)

Max. load radial to shaft: 67 lb (300 N)  
 Max. load axial to shaft: 67 lb (300 N)  
 Repeatability: +/- 320 Arc sec  
 Torque at 72.5 psi (5 bar) : 3.36 lb.in (0.38 Nm)

Order No. MD 12/ 90 A  
 MD 12/180 A

## Model B

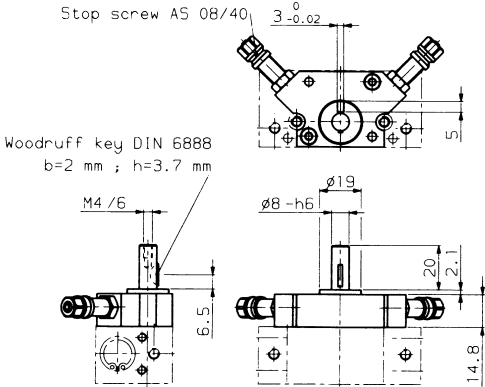

Type	Angle of rotation	Air consumption for each double stroke at 72.5 psi (5 bar)	Weight
MD 12/ 90 B	0 - 90°	.001 scf (0.02 NL)	.77 lb (0.35 kg)
MD 12/180 B	0 - 180°	.002 scf (0.04 NL)	.88 lb (0.40 kg)

Max. load radial to shaft: 34 lb (150 N)  
 Max. load axial to shaft: 54 lb (240 N)  
 Repeatability: +/- 320 Arc sec  
 Torque at 72.5 psi (5 bar) : 3.36 lb.in (0.38 Nm)

Order No. MD 12/ 90 B  
 MD 12/180 B

## Technical data:

- Built in patented stop screws with fine threads provide for stepless adjustable angle of rotation.
- The stop screws can be fitted with patented sensing elements (see section "Stop Screws with plug-in sensing elements").
- Intermediate position can be added.
- Designed for high operating rates and long life.

- Operating medium Compressed air or hydraulic oil
- Operating pressure 43.5 - 116 psi (3 - 8 bar)
- Air connection M5

# Rotary Actuator MD 12/180 H

Rotary actuator with hollow shaft

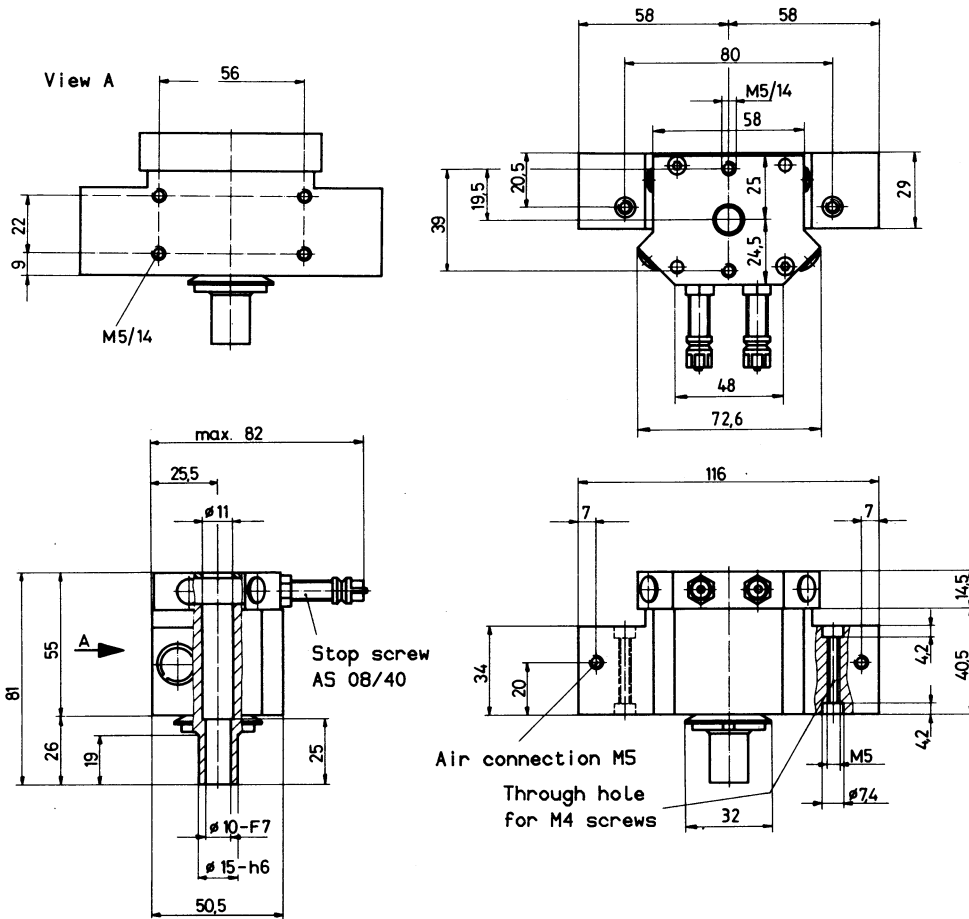

Type	Angle of rotation	Max. load radial to shaft	Max. load axial to shaft	Torque at 72.5 psi (5 bar)	Air consumption for each double stroke at 72.5 psi (5 bar)	Weight	Order No.
MD 12/180 H	0–180°	337 lb (1500 N)	34 lb (150 N)	4.07 lb.in (0,46 Nm)	.002 scf (0,04 NL)	1.65 lb (0,75 kg)	MD 12/180 H

## Technical data:

- Built in patented stop screws with fine threads provide for stepless adjustable angle of rotation.
- The stop screws can be fitted with patented sensing elements (see section "Stop Screws with plug-in sensing elements").
- Intermediate position can be added. (see sheet 3.051)
- Designed for high operating rates and long life.

- Operating medium: Compressed air or hydraulic oil
- Operating pressure: 43.5 - 116 psi (3 - 8 bar)
- Repeatability: ± 190 Arc sec
- Air connection: M5

# Rotary Actuator MD 12 D/180 H

Rotary actuator with hollow shaft and 2 piston

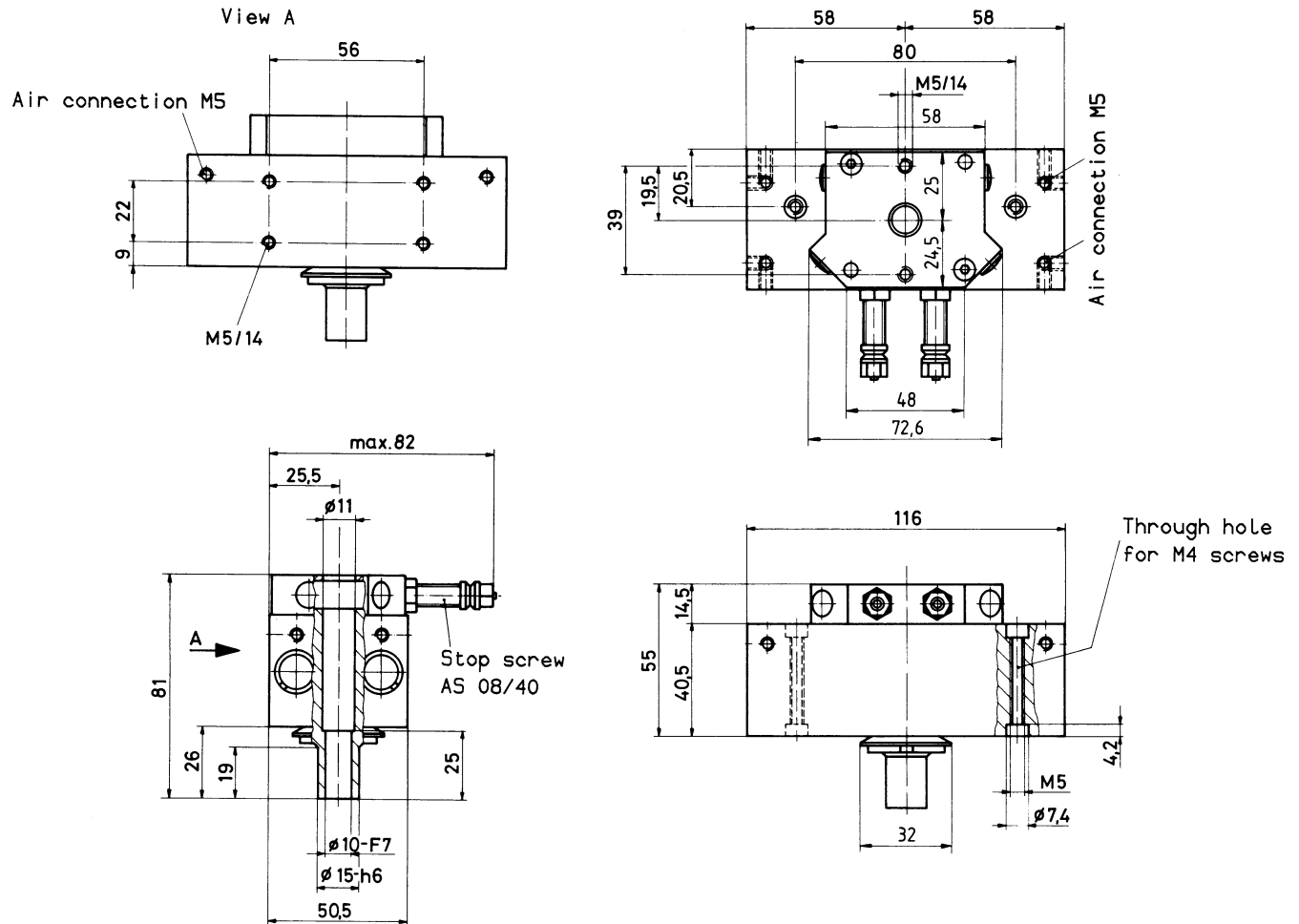

Type	Angle of rotation	Max. load radial to shaft	Max. load axial to shaft	Torque at 72.5 psi (5 bar)	Air consumption for each double stroke at 72.5 psi (5 bar)	Weight	Order No.
MD 12 D/180 H	0–180°	337 lb (1500 N)	34 lb (150 N)	8.14 lb.in (0,92 Nm)	.003 scf (0,08 NL)	2.09 lb (0,95 kg)	MD 12 D/180 H

## Technical data:

- Built in patented stop screws with fine threads provide for stepless adjustable angle of rotation.
- The stop screws can be fitted with patented sensing elements (see section "Stop Screws with plug-in sensing elements").
- Intermediate position can be added. (see sheet 3.051)
- Designed for high operating rates and long life.

- Operating medium
- Operating pressure
- Repeatability
- Air connection

- Compressed air or hydraulic oil
- 43.5 - 116 psi (3 - 8 bar)
- ± 190 Arc sec
- M5

# Rotary Actuator MD 12/90V

Rotation:	0-90 degrees
Max Load Radial To Shaft:	34 lb (150 N)
Max Load Axial To Shaft:	54 lb (240 N)
Repeatability:	±320 ARC SEC.
Torque:	3.36 lb IN (.38 Nm)
Operating Medium:	compressed air or hydraulic oil
Operating Pressure:	43.5-116 PSI (3-8 bar)
Air Connection:	M5
Air Consumption For Each Double Stroke:	0.001 scf (0.02 NL)
Weight:	0.77 lb. (0.35 kg)

**Order No.:** MD12/90V

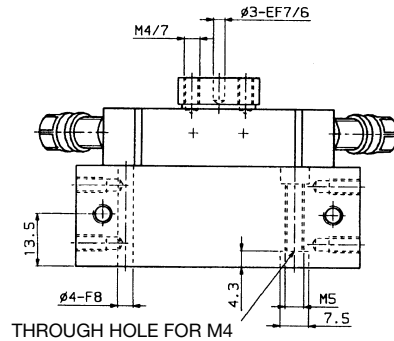
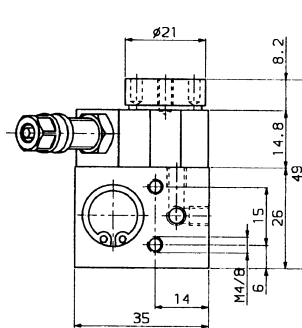
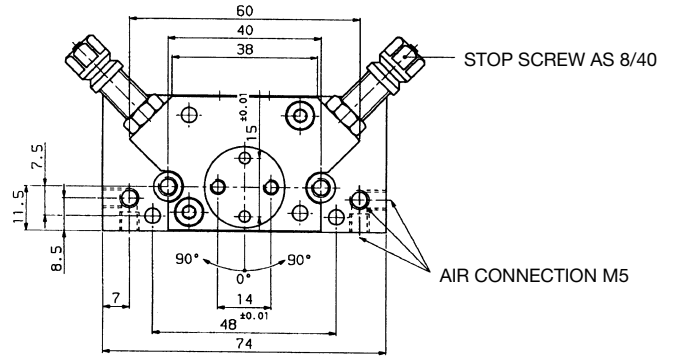

# Rotary Actuator MD 12/180V

Rotation:	0-180 degrees
Max Load Radial To Shaft:	34 lb (150 N)
Max Load Axial To Shaft:	54 lb (240 N)
Repeatability:	±320 ARC SEC.
Torque:	3.36 lb IN (.38 Nm)
Operating Medium:	compressed air or hydraulic oil
Operating Pressure:	43.5-116 PSI (3-8 bar)
Air Connection:	M5
Air Consumption For Each Double Stroke:	0.002 scf (0.04 NL)
Weight:	0.88 lb. (0.40 kg)

**Order No.:** MD12/180V

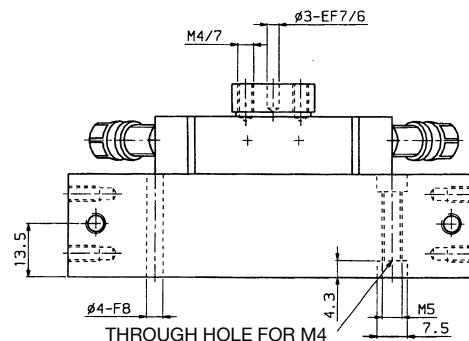
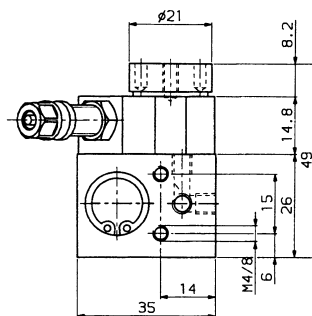
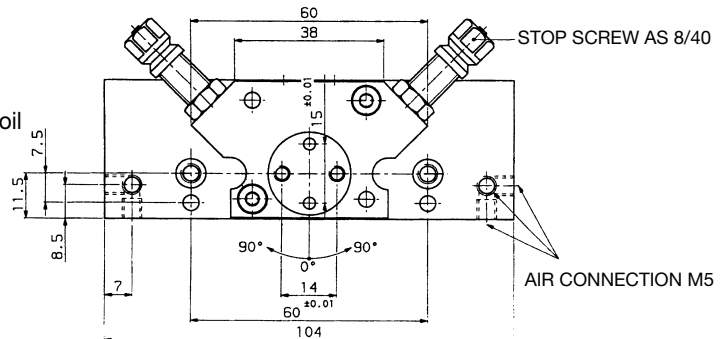

## Technical data:

- Built in patented stop screws with fine threads provide adjustable angle of rotation.
- The stop screws can be fitted with patented sensing elements (see section "Stop Screws with plug-in sensing elements")
- Designed for high operating rates

# Rotary Actuator MD 20/180

## Model S

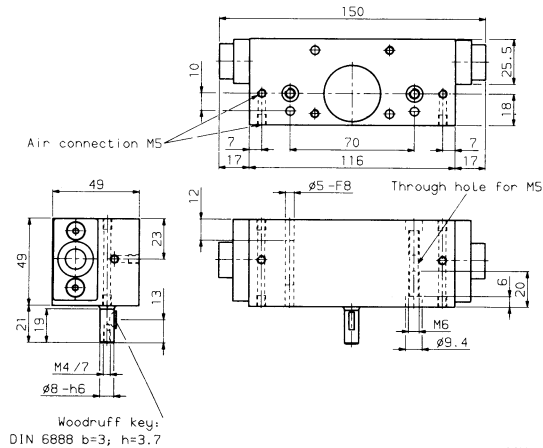

## Model A

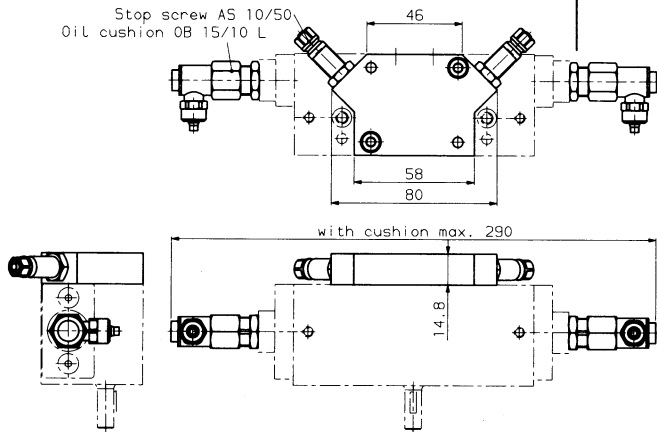

## Model B

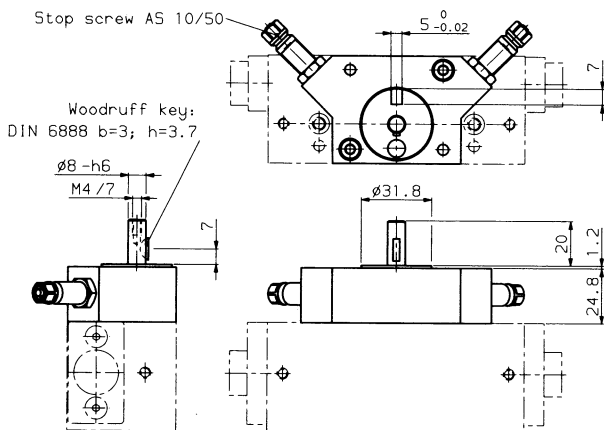

Type	Angle of rotation	Air consumption for each double stroke at 5 bar	Weight
MD 20/180 S	180°	.004 scf (0.12 NL)	2.0 lb (0.9 kg)

Max. load radial to shaft: 79 lb (350 N)  
 Max. load axial to shaft: 61 lb (270 N)

Torque at 72.5 psi (5 bar) : 9.74 lb.in (1.1 Nm)

**Order No.**

MD 20/180 S  
 MD 20/180 S1 end cover for oil cushions or elastomer cushions

OIL CUSHIONS = OB 15/IOL  
 ELASTOMER = KB08/M14X1

Type	Angle of rotation	Air consumption for each double stroke at 5 bar	Weight
MD 20/180 A	0 - 180°	.004 scf (0.12 NL)	2.4 lb (1.1 kg)

Max. load radial to shaft: 79 lb (350 N)  
 Max. load axial to shaft: 61 lb (270 N)  
 Repeatability: +/- 200 Arc sec  
 Torque at 72.5 psi (5 bar) : 9.74 lb.in (1.1 Nm)

**Order No.**

MD 20/180 A  
 MD 20/180 A1 end cover for oil cushions or elastomer cushions

NOTE: when using cushions need 2 nuts, o-rings (MU01.008)

Type	Angle of rotation	Air consumption for each double stroke at 5 bar	Weight
MD 20/180 B	0 - 180°	.004 scf (0.12 NL)	2.6 lb (1.2 kg)

Max. load radial to shaft: 40 lb (180 N)  
 Max. load axial to shaft: 67 lb (300 N)  
 Repeatability: +/- 200 Arc sec  
 Torque at 72.5 psi (5 bar) : 9.74 lb.in (1.1 Nm)

**Order No.**

MD 20/180 B  
 MD 20/180 B1 end cover for oil cushions or elastomer cushions

**Technical data:**

- Built in patented stop screws with fine threads provide for stepless adjustable angle of rotation.
  - The stop screws can be fitted with patented sensing elements (see section "Stop Screws with plug-in sensing elements").
  - Intermediate position can be added (on model B).
  - Designed for high operating rates and long life.
  - Operating medium Compressed air or hydraulic oil
  - Operating pressure 43.5 - 116 psi (3 - 8 bar)
  - Air connection M5
- Cushions page 5.001

# Rotary Actuator MD 20/360

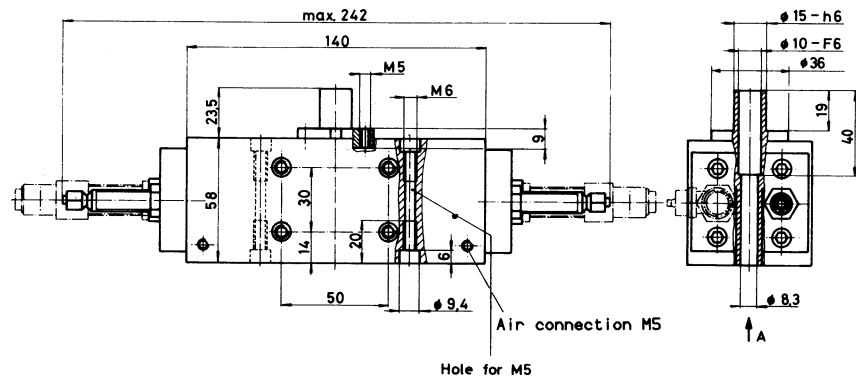
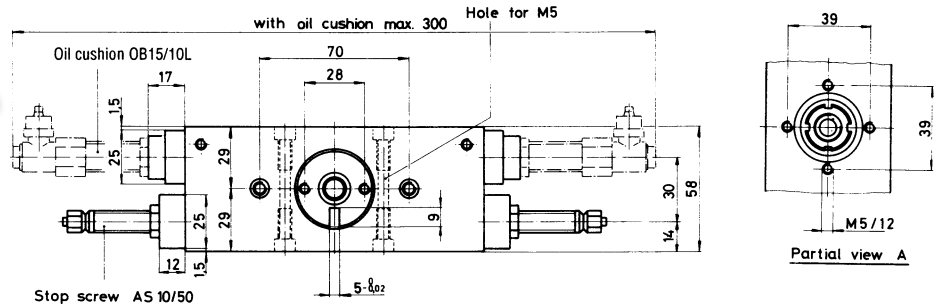

Type	Angle of rotation	Max. load radial to shaft	Max. load axial to shaft	Torque at 72.5 psi (5 bar)	Air consumption for each double stroke 72.5 psi (5 bar)	Weight
MD 20/360	0–360°	337 lb (1500 N)	34 lb (150 N)	7.26 lb.in (0,82 Nm)	.006 scf (0,17 NL)	4.0 lb (1,8 kg)

**Order No.**

MD 20/360

MD 20/360-1 end cover for oil cushions or elastomer cushions

**Technical data:**

- Built in patented stop screws with fine threads provide for stepless adjustable angle of rotation.
- The stop screws can be fitted with patented sensing elements (see section "Stop Screws with plug-in sensing elements").
- End position can be damped with adjustable oil cushions.
- Designed for high operating rates and long life.
- Operating medium Compressed air or hydraulic oil
- Operating pressure 43.5 - 116 psi (3 - 8 bar)
- Repeatability ± 294 Arc sec
- Air connection M5

Cushions page 5.001

# Rotary Actuator MD 20/180V

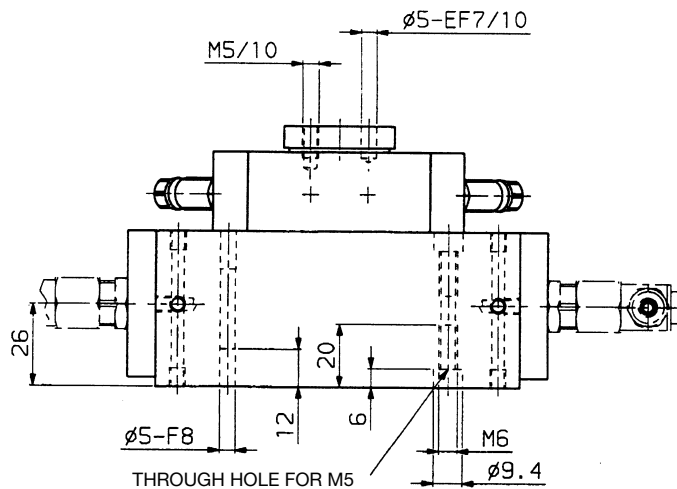
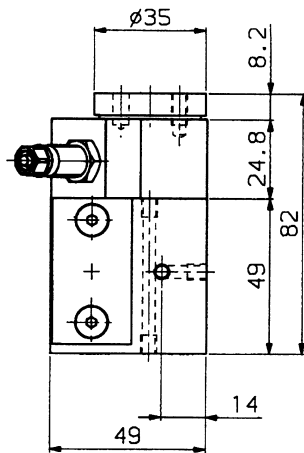
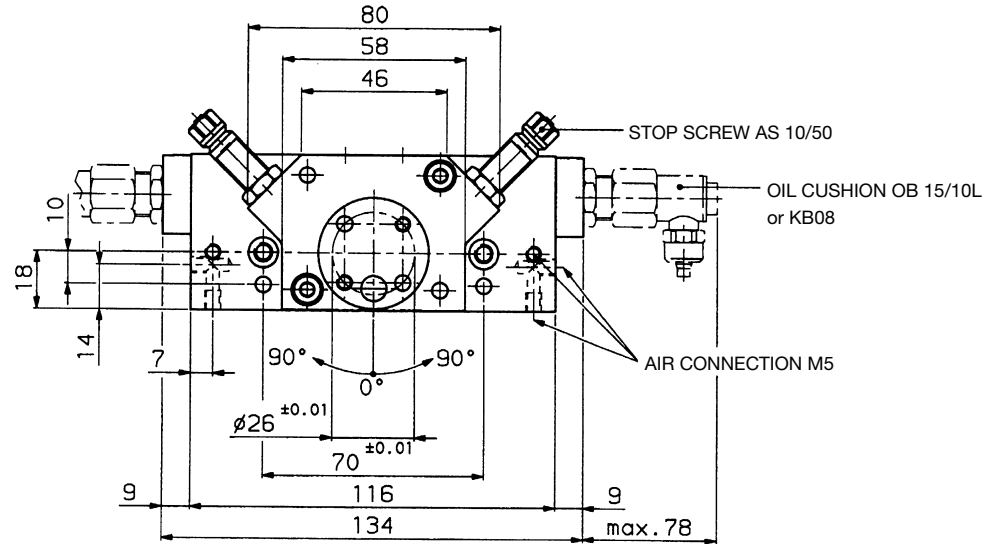
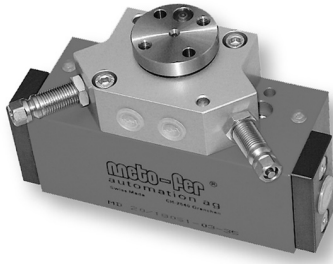

Rotation:	0-180 degrees
Max Load Radial To Shaft:	40 lb (180 N)
Max Load Axial To Shaft:	67 lb (300 N)
Repeatability:	±200 ARC SEC.
Torque:	9.74 lb IN (1.1 Nm)
Operating Medium:	compressed air or hydraulic oil
Operating Pressure:	43.5-116 PSI (3-8 bar)
Air Connection:	M5
Air Consumption For Each Double Stroke:	0.004 scf (0.12 NL)
Weight:	2.6 lb. (1.20 kg)

**Order No.:** MD20/180V  
MD20/180V1 WITH END COVER FOR OIL OR ELASTOMER CUSHIONS

### Technical data:

- Built in patented stop screws with fine threads provide adjustable angle of rotation.
- The stop screws can be fitted with patented sensing elements (see section "Stop Screws with plug-in sensing elements")
- End position can be damped with adjustable oil cushions. (OB15/10L) or Elastomer (KB08)
- Designed for high operating rates





# Rotary Actuator MD 32/180V

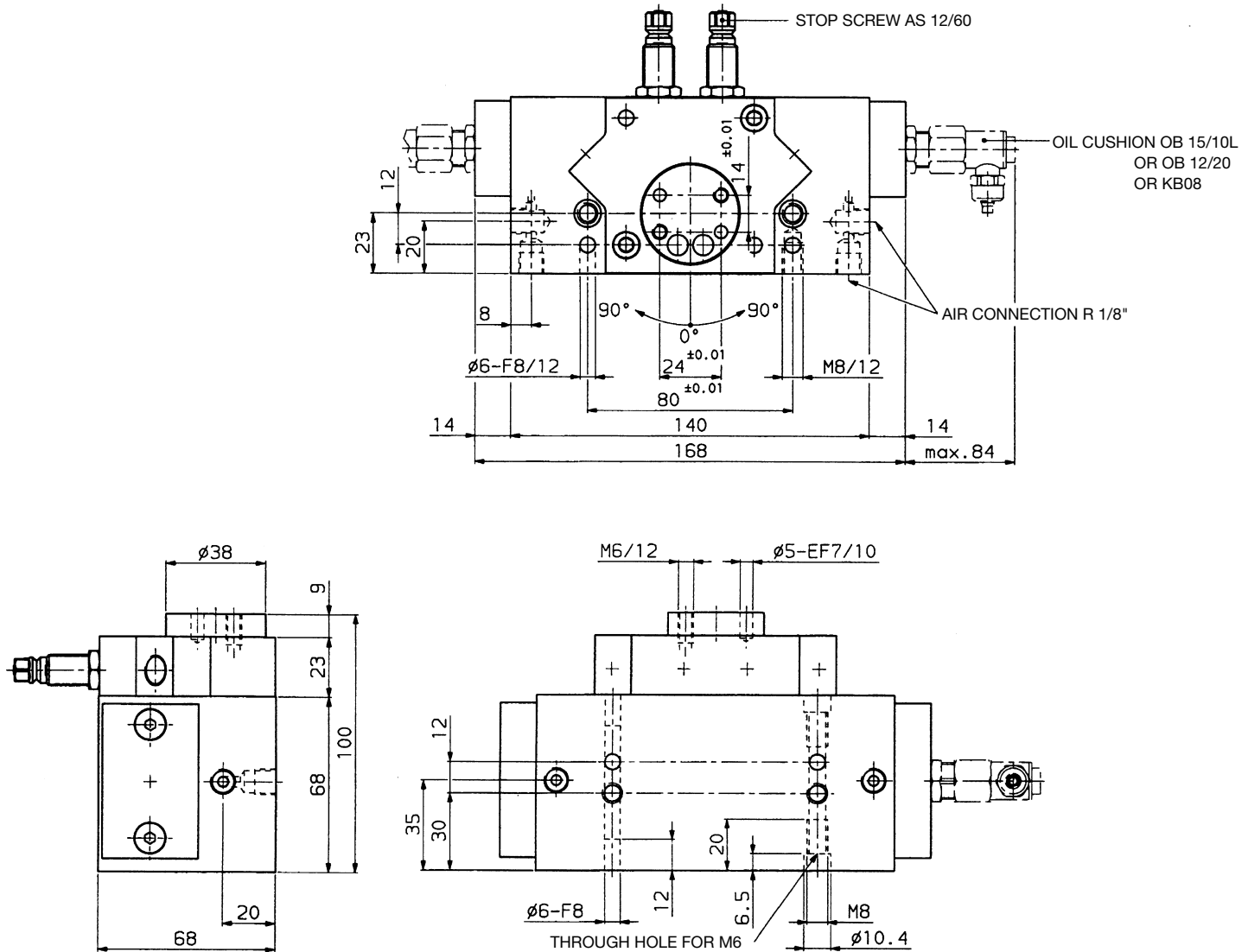

Rotation:	0-180 degrees
Max Load Radial To Shaft:	124 lb (550 N)
Max Load Axial To Shaft:	169 lb (750 N)
Repeatability:	±150 ARC SEC.
Torque:	31.86 lb IN (3.6 Nm) 72.5 PSI (5 bar)
Operating Medium:	compressed air or hydraulic oil
Operating Pressure:	43.5-116 PSI (3-8 bar)
Air Connection:	G 1/8"
Air Consumption For Each Double Stroke:	0.013 scf (0.37 NL) 72.5 PSI (5 bar)
Weight:	5.9 lb. (2.70 kg)



**Order No.:** MD32/180V  
MD32/180V1 WITH END COVER FOR OIL OR ELASTOMER CUSHIONS

### Technical data:

- Built in patented stop screws with fine threads provide adjustable angle of rotation.
- The stop screws can be fitted with patented sensing elements (see section "Stop Screws with plug-in sensing elements")
- End position can be damped with adjustable oil cushions. (OB15/10L or OB12/20) or Elastomer (KB08)
- Designed for high operating rates

# Rotary Actuator MD 51/180 B

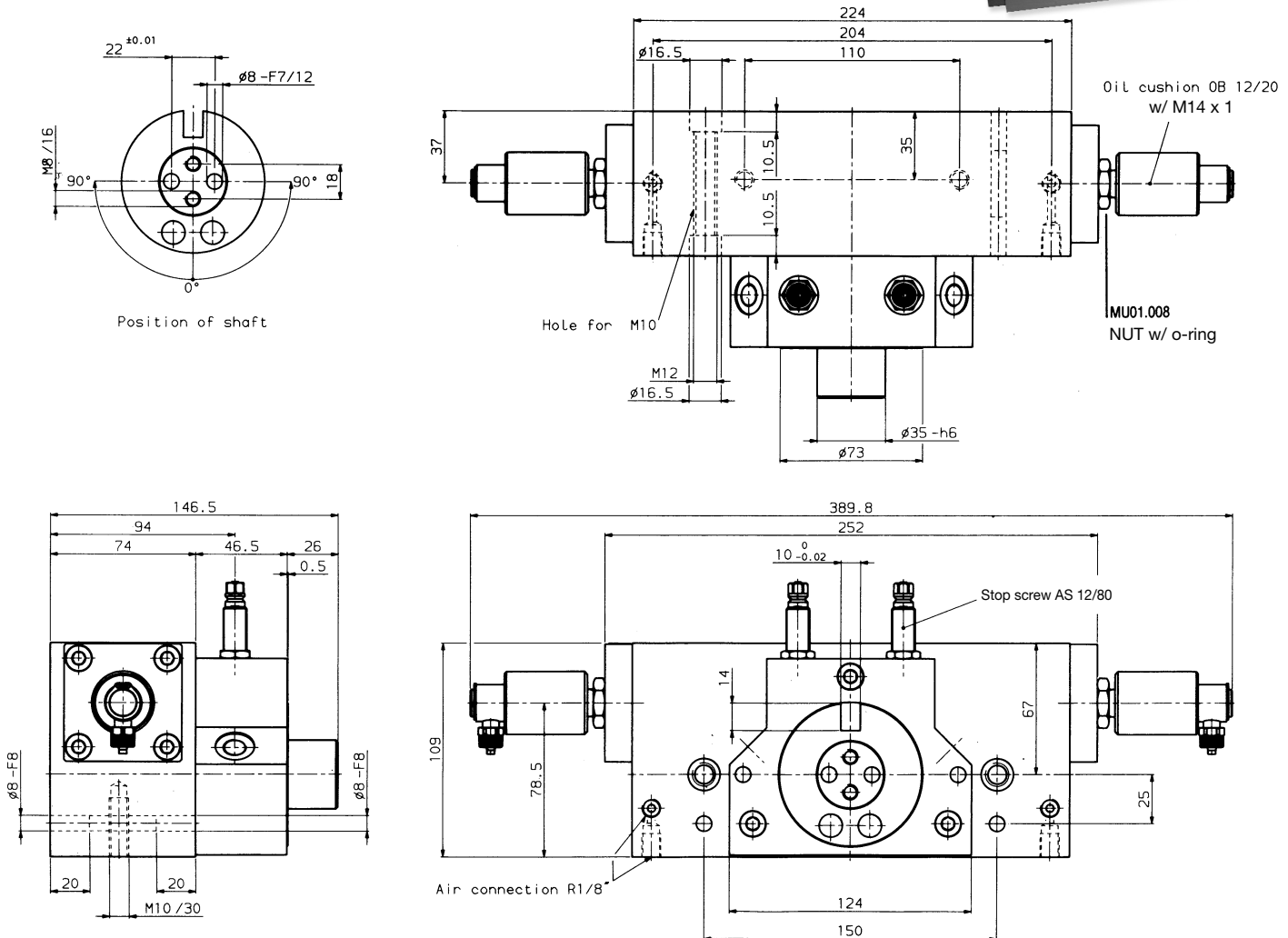

Type	Angle of rotation	Max. load radial to shaft	Max. load axial to shaft	Torque at 72.5 psi (5 bar)	Air consumption for each double stroke at 5 bar	Weight
MD 51/180B	0-180°	1124 lb (5000 N)	629 lb (2800 N)	117.3 lb.in (13.25 Nm)	0.048 scf (1.35 NL)	17.9 lb (8.1 kg)

## Order No.

MD 51/180 B

MD 51/180 B1 with end cover for oil cushions

## Technical data:

- Built in patented stop screws with fine threads provide for stepless adjustable angle of rotation.
- The stop screws can be fitted with patented sensing elements (see section "Stop Screws with plug-in sensing elements").
- End position can be damped with adjustable oil cushions.
- Intermediate position can be added.
- Designed for high operating rates and long life.

- Operating medium
- Operating pressure
- Repeatability
- Air connection

Compressed air or hydraulic oil  
 43.5 - 116 psi (3 - 8 bar) Cushions page 5.001  
 +/- 75 Arc sec  
 R 1/8"

# Rotary Actuator MD 51 D/180

## Rotary actuator with 2 piston

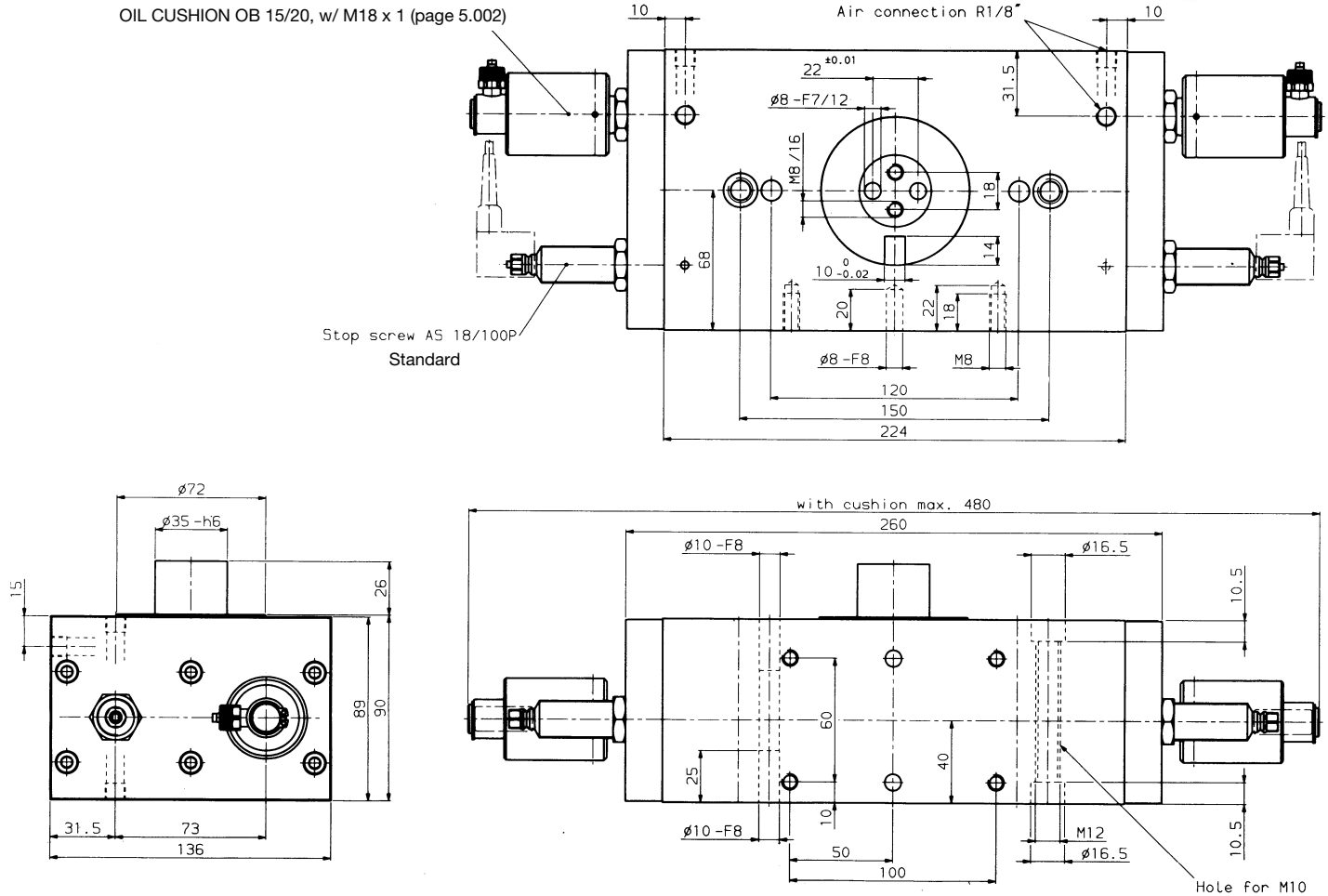
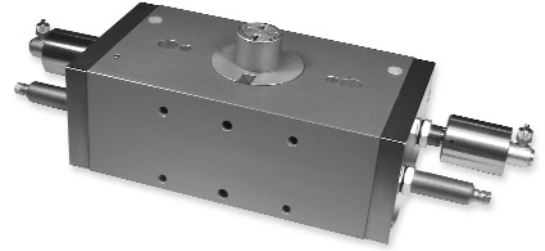

Type	Angle of rotation	Max. load radial to shaft	Max. load axial to shaft	Torque at 72.5 psi (5 bar)	Air consumption for each double stroke at 5 bar	Weight
MD 51 D/180	0-180°	1124 lb (5000 N)	629 lb (2800 N)	234.5 lb.in (26.50 Nm)	0.060 scf (1.70 NL)	22.4 lb (10.2 kg)

**Order No.:** MD 51D/180 - O  
 MD 51D/180 - A  
 MD 51D/180 - B

O = without oil cushions  
 A = with oil cushions  
 B = with oil cushions and KOB (page 5.001)

### Technical data:

- Built in patented stop screws with fine threads provide for stepless adjustable angle of rotation.
- The stop screws can be fitted with patented sensing elements (see section "Stop Screws with plug-in sensing elements").
- End position can be damped with adjustable oil cushions.
- Intermediate position can be added.
- Designed for high operating rates and long life.

-Operating medium	Compressed air or hydraulic oil
-Operating pressure	43.5 - 116 psi (3 - 8 bar)
-Repeatability	+/- 190 Arc sec
-Air connection	R 1/8"

### Intermediate position

for MD12/180

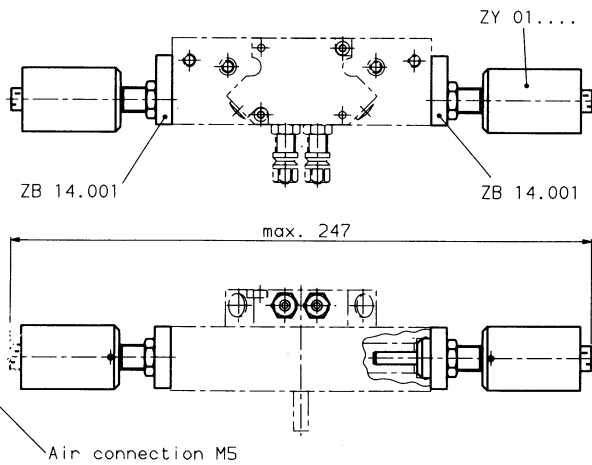

**Order No.**  
 Cylinder ZY 01....  
 End cover ZB 14.001

### Intermediate position

for MD12D/180H and ZD12D/180

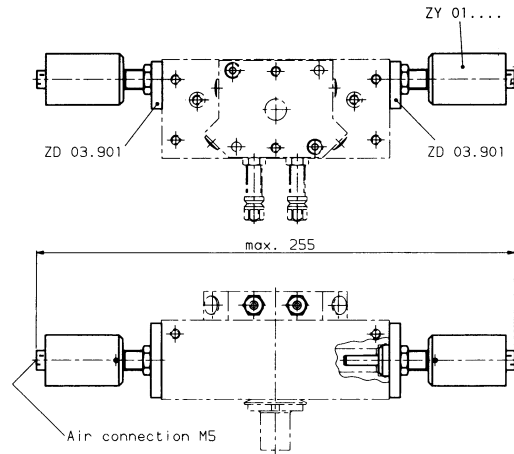

**Order No.**  
 Cylinder ZY 01....  
 End cover ZD 03.901

### Intermediate position

for MD12/180H and ZD12/180

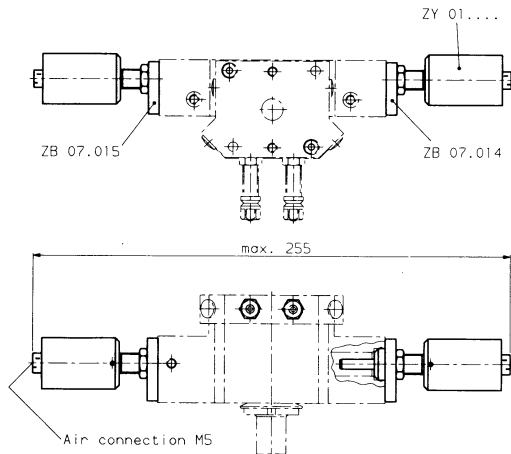

**Order No.**  
 Cylinder ZY 01....  
 End cover ZB 07.014  
 End cover ZB 07.015

### Intermediate position

Possible adjustments

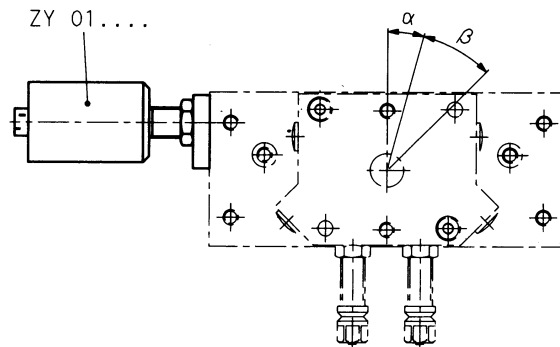

Dimensions of  $\alpha$  and  $\beta$  see table of Cylinder ZY

## Cylinder ZY

**Technical data:**

- Stroke return movement has to occur mechanical (Piston of rotary drive)
- Operating medium Compressed air
- Operating pressure 43.5 - 116 psi (3 - 8 bar)
- Air connection M5

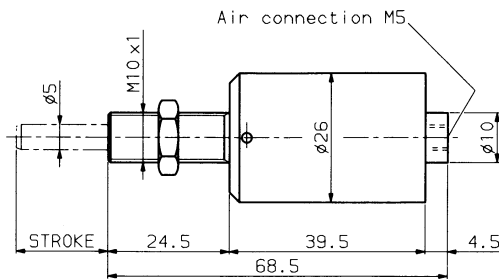

Type	Stroke	$\alpha$	$\beta$	Piston force at 72.5 psi (5 bar)	Air consumption for each stroke at 72.5 psi (5 bar)	Weight	Order No.
ZY 01.000	18.5	0°	0-30°	27 lb (118 N)	0.0012 scf (0.035 NL)	0.11 lb (0.05 kg)	ZY 01.000
ZY 02.000	15.5	15°	0-30°	27 lb (118 N)	0.0010 scf (0.029 NL)	0.11 lb (0.05 kg)	ZY 02.000
ZY 03.000	12.5	30°	0-30°	27 lb (118 N)	0.0008 scf (0.024 NL)	0.11 lb (0.05 kg)	ZY 03.000
ZY 04.000	9.5	45°	0-30°	27 lb (118 N)	0.0006 scf (0.018 NL)	0.11 lb (0.05 kg)	ZY 04.000
ZY 05.000	6.5	60°	0-30°	27 lb (118 N)	0.0004 scf (0.012 NL)	0.11 lb (0.05 kg)	ZY 05.000

# Rotary gripper head ZD 12/180 Rotary gripper head for Vertical units VE

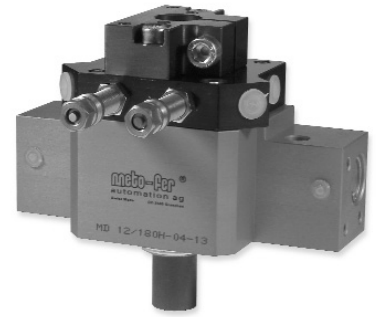
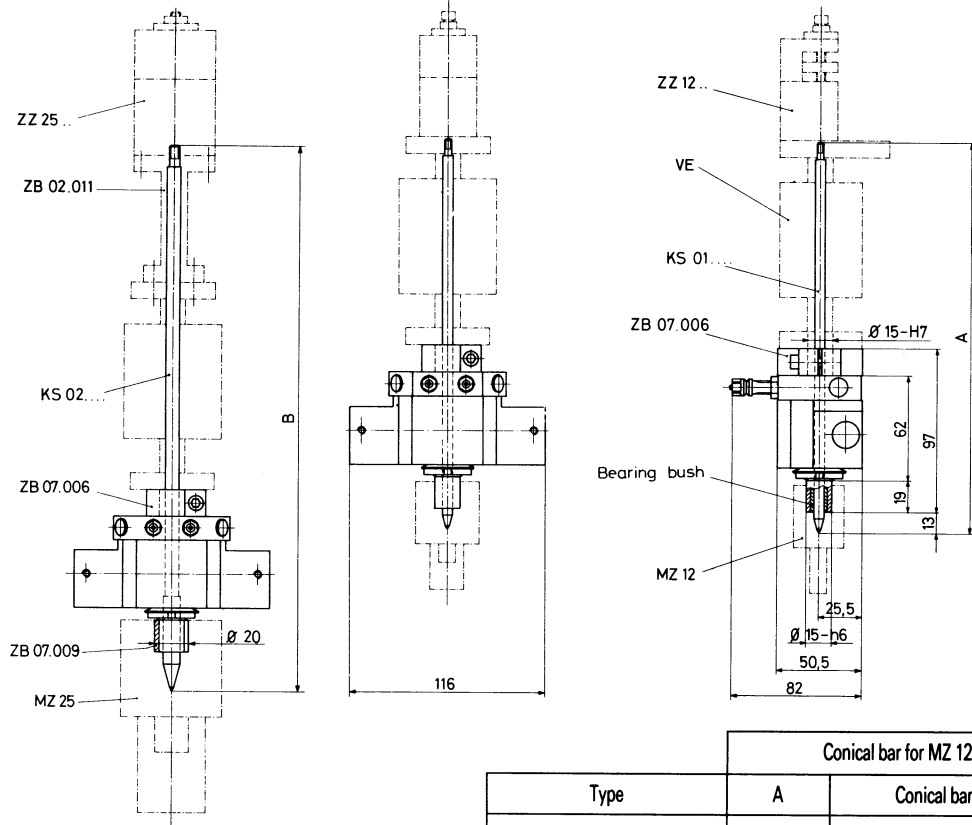

Type	Conical bar for MZ 12		Conical bar for MZ 25	
	A	Conical bar No.	B	Conical bar No.
ZD 12/180	—	—	—	—
ZD 12/180 VE 22	231	KS 01.017	324	KS 02.004
ZD 12/180 VE 52	291	KS 01.018	384	KS 02.008
ZD 12/180 VE 82	351	KS 01.019	444	KS 02.000

Technical data: Sheet 3.011

Rotary gripper head and support must be ordered separately.  
**Order No.** for Rotary gripper head (delivery as per photo) ZD 12/180  
**Order No.** for Split sleeve ZB 07.009  
**Order No.** for Conical bar KS .....

Rotary gripper head for use with rotary loader arms

No. of Conical bar

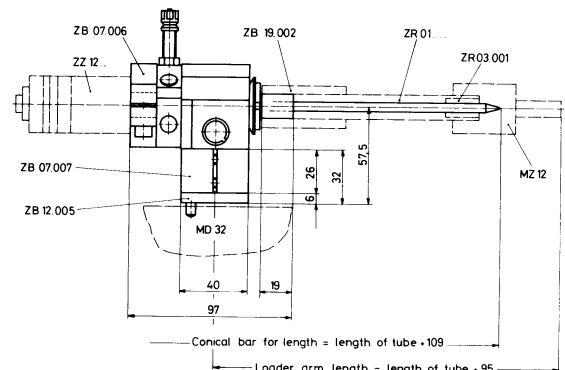
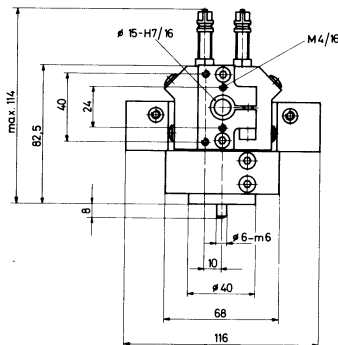
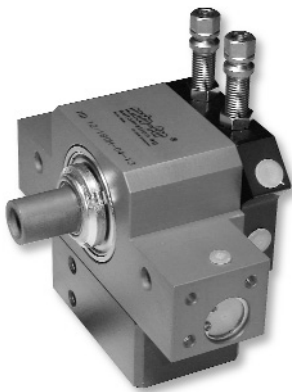
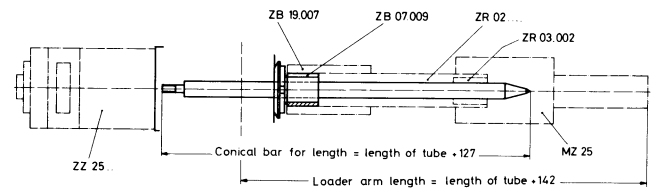

Technical data: Sheet 3.011

Rotary gripper head and support must be ordered separately.  
**Order No.** for Rotary gripper head (delivery as per photo) ZD 12/180L  
**Order No.** for Conical bar see sheet 8.022  
**Order No.** for Gripper mounting tubes see sheet 8.022

# Rotary gripper head ZD 12D/180 Rotary gripper head for Vertical units VE

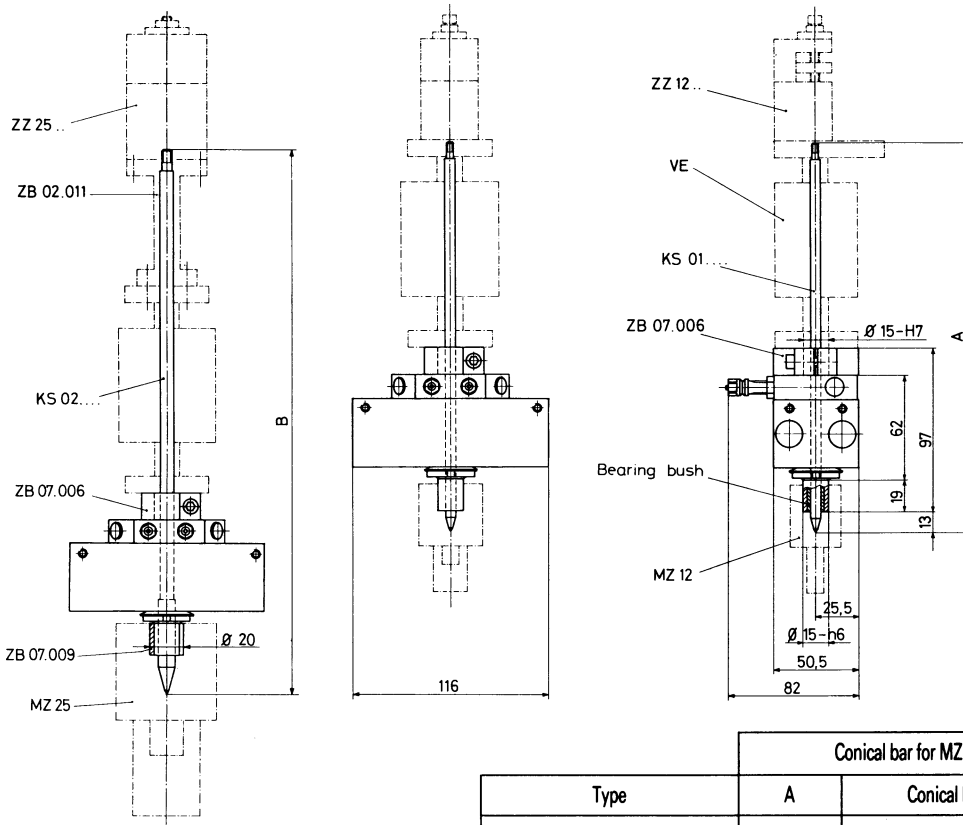

Type	Conical bar for MZ 12		Conical bar for MZ 25	
	A	Conical bar No.	B	Conical bar No.
ZD 12D/180	—	—	—	—
ZD 12D/180 VE 22	231	KS 01.017	324	KS 02.004
ZD 12D/180 VE 52	291	KS 01.018	384	KS 02.008
ZD 12D/180 VE 82	351	KS 01.019	444	KS 02.000

**Technical data:** Sheet 3.012

Rotary gripper head and support must be ordered separately.

**Order No.** for Rotary gripper head (delivery as per photo) ZD 12D/180

**Order No.** for Split sleeve ZB 07.009

**Order No.** for Conical bar KS . . . . .



Rotary gripper head for use with rotary loader arms

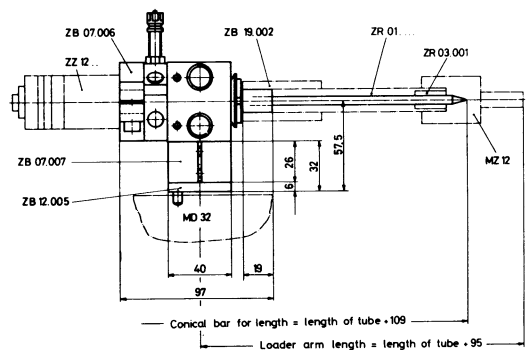
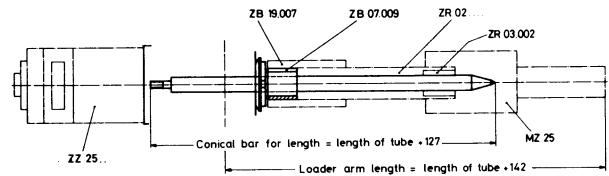
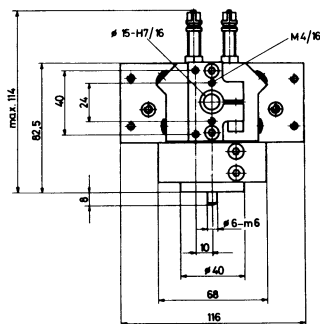
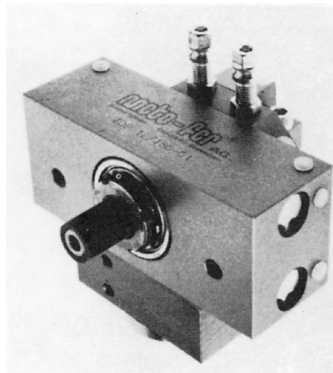

**Technical data:** Sheet 3.012

Rotary gripper head and support must be ordered separately.

**Order No.** for Rotary gripper head (delivery as per photo) ZD 12/180L

**Order No.** for Conical bar see sheet 8.022

**Order No.** for Gripper mounting tubes see sheet 8.022

# Rotary gripper head ZD 20/360

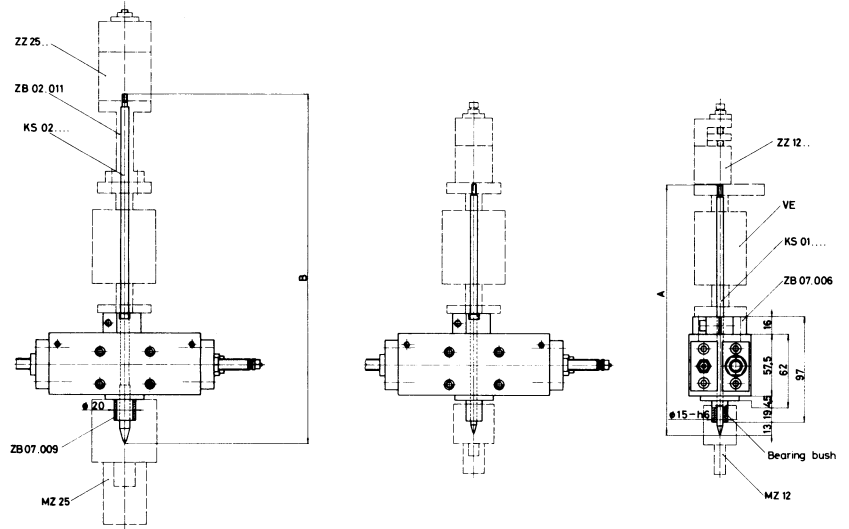
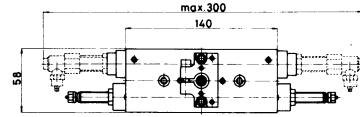

Type	Angle of rotation	Max. load radial	Max. load axial	Torque at 72.5 psi (5 bar)	Air consumption for each double stroke at 72.5 psi (5 bar)	Weight
ZD 20/360	0–360°	337 lb (1500 N)	34 lb (150 N)	7.26 lb. in (0,82 Nm)	.006 scf (0,17 NL)	4.2 lb (1,9 kg)

Type	Conical bar for MZ 12		Conical bar for MZ 25	
	A	Conical bar No.	B	Conical bar No.
ZD 20/360	—	—	—	—
ZD 20/360 VE 22	231	KS 01.017	324	KS 02.004
ZD 20/360 VE 52	291	KS 01.018	384	KS 02.008
ZD 20/360 VE 82	351	KS 01.019	444	KS 02.000

Rotary gripper head and support must be ordered separately.

### Order No.

ZD 20/360

ZD 20/360-1 end cover for oil cushions or elastomer cushions

### Order No. for Conical bar

KS.....

— No. of Conical bar

### Order No. for Split sleeve

ZB 07.009

### Technical data:

- Built in patented stop screws with fine threads provide for stepless adjustable angle of rotation.
- The stop screws can be fitted with patented sensing elements (see section "Stop Screws with plug-in sensing elements").
- Designed for high production rates and long life.
- Ball bearings

-Operating medium	Compressed air or hydraulic oil
-Operating pressure	43.5 - 116 psi (3 - 8 bar)
-Repeatability	+/- 294 Arc sec
-Air connection	M5



# Angle Loader WL

Individual angle loader components are available in various versions and should, therefore, be ordered separately. Components can be determined with the aid of the following list according to the description.

Description	Sheet	Description	Sheet
KOB	Compensation reservoir.....5.001	SD 01.001	Stand base .....6.002
* KS...	Conical bar .....	SD 01.005	Mounting plate .....6.002
LH...	Linear unit .....1.001	SE 01.001	Stand base .....6.001
MD 32/180 B...	Rotary drive.....3.031	SE 01.004	Mounting plate .....6.001
MD 51/180 B...	Rotary drive.....3.041	VE...	Vertical unit.....1.011
* MZ 12	Mechanical gripper .....4.001	ZB 02.007	Plate .....
OB 15/10L	Oil cushion .....5.001	ZB 11.021	Plate .....
OB 12/20	Oil cushion .....5.001	ZB 12.005	Flange (MD 32) .....
Pillar ø 40 x...	Pillar .....6.002	ZZ 12...	Gripper cylinder .....4.001

\* KS, MZ 12 und ZZ 12 can be ordered as NW... (Sheet 4.001).

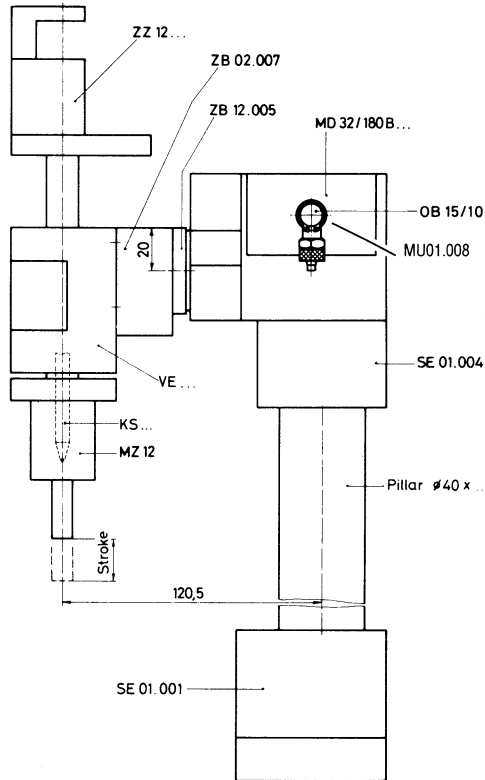
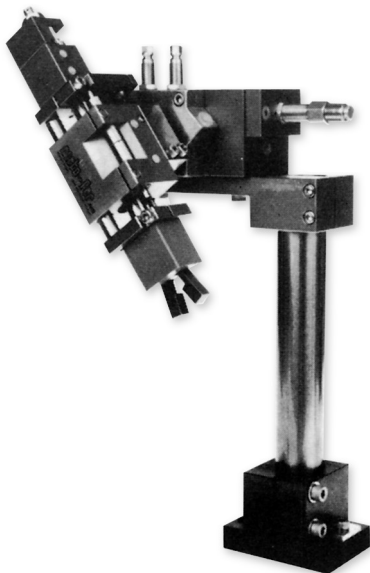

The oil cushions and the compensation reservoir for the rotary drive have to be ordered separately. Page 5.001

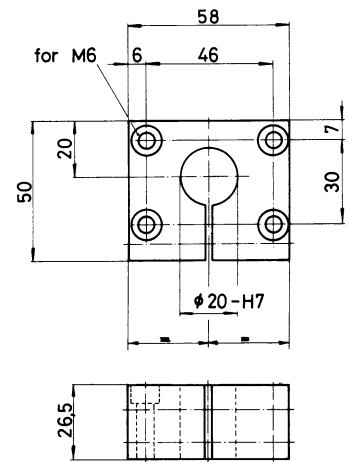
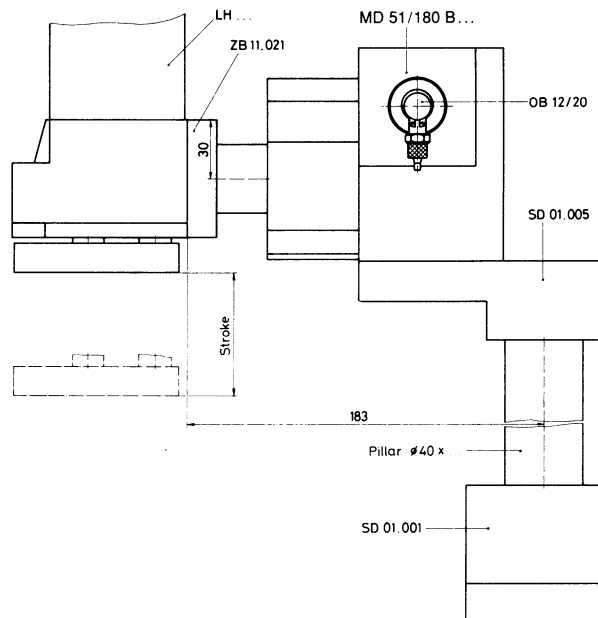
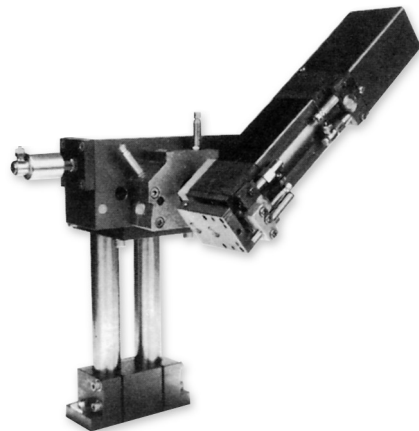

Plate  
Order No. ZB 02.007

WL 32



The oil cushions for the rotary drive must be ordered separately. The compensation reservoir is included with the linear unit.

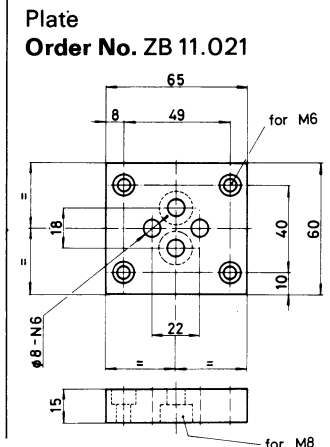

Plate  
Order No. ZB 11.021

WL 51

**GRIPPERS: ANGULAR, SEMI-PARALLEL, 180° ANGULAR, PARALLEL,  
THREE FINGER ANGULAR**

**SECTION 4**

**meto-fer®**  
**automation**

**Your complete source for industrial automation and electronics**

**mf automation, inc.**

[www.meto-fer.com](http://www.meto-fer.com)

1-888-638-6337

# Mechanical Gripper (use with Hollow Shaft Units)

ZZ12 / ZZ25

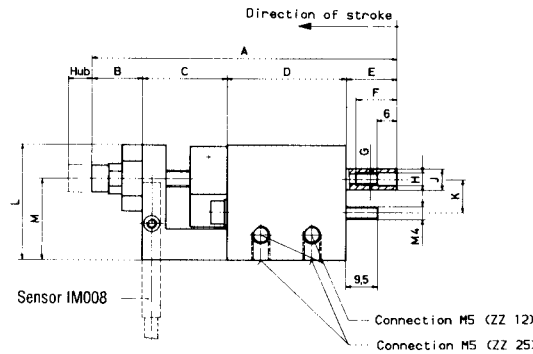
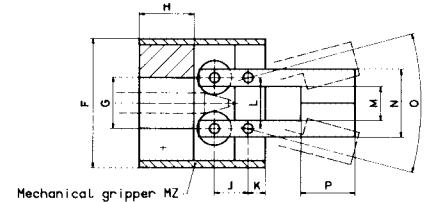
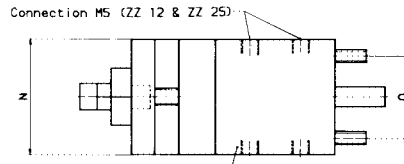
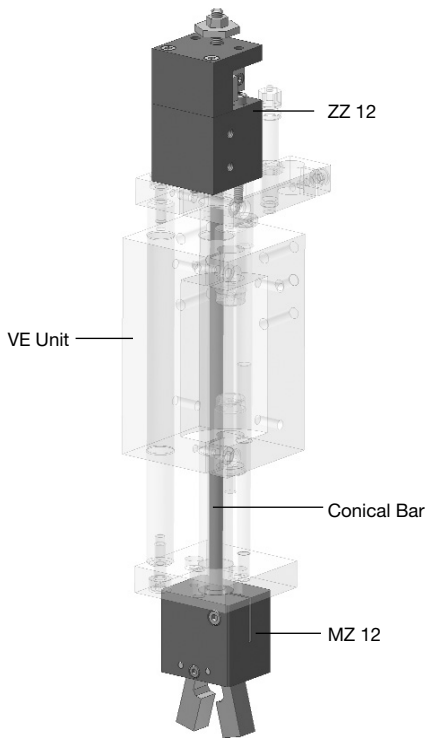

Type	Piston force at 72.5 psi (5 bar)	Air consumption for each double stroke at 72.5 psi (5 bar)	Weight
ZZ 12	7 lb (31 N)	.00025 scf (0,007 NL)	.4 lb (0,2 kg)
ZZ 25	35 lb (154 N)	.00177 scf (0,05 NL)	1.1 lb (0,5 kg)

Type	Stroke	A	B	C	D	E	F	G	Ø H	Ø J	K	L	M	N	O
ZZ 12	0-7	90	15	25	35	15	12	M4	4 <sup>+0,06</sup> / <sub>+0,04</sub>	6 <sup>-0,010</sup> / <sub>-0,025</sub>	—	34	24	34	24
ZZ 25	0-10	94	9,5	29	45	10,5	14	M5	6 <sup>+0,04</sup> / <sub>+0,02</sub>	10 <sup>-0,005</sup> / <sub>-0,020</sub>	10	46	29	48	40

Order No. ZZ12 ZZ25

Sensor IM-008-NS-U2L (1 pc. to sense when gripper is closed)  
 Order No. IM-008-PS-U2L

**Technical data:**

- Operating medium Compressed air oiled / not oiled
- Operating pressure 42.5 – 116 psi (3 – 8 bar)
- Air connection M5

## Mechanical gripper MZ

Typ	A	B	C	D	E	F	ØG	H	J	K	L	M	N	O	P	Weight	Clamping force at 72.5 psi (5 bar)	Order No.
MZ 12	63.5	37	26.5	10	30	38	15 - H7	16	10	5	15	10	20	29°	16	0.27 lb (0.12 kg)	4 lb (18 N)	MZ 12
MZ 25	114	57	57	20	40	60	20 - H7	19	20	6	30	20	40	23°	36	1.45 lb (0.66 kg)	20 lb (90 N)	MZ 25

## Mechanical gripper for vertical units

Order No.

NW ... VE ...

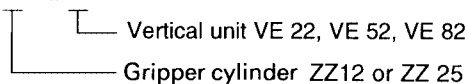

**Ordering example:**

- NW 12 VE 22 NW 12 consists of: MZ 12, ZZ 12 and Conical bar
- NW 25 VE 22 NW 25 consists of: MZ 25, ZZ 25 and Conical bar, Adapter ZB 02.011 and Gripper bracket ZB 02.012

# Mounting flange for compact grippers

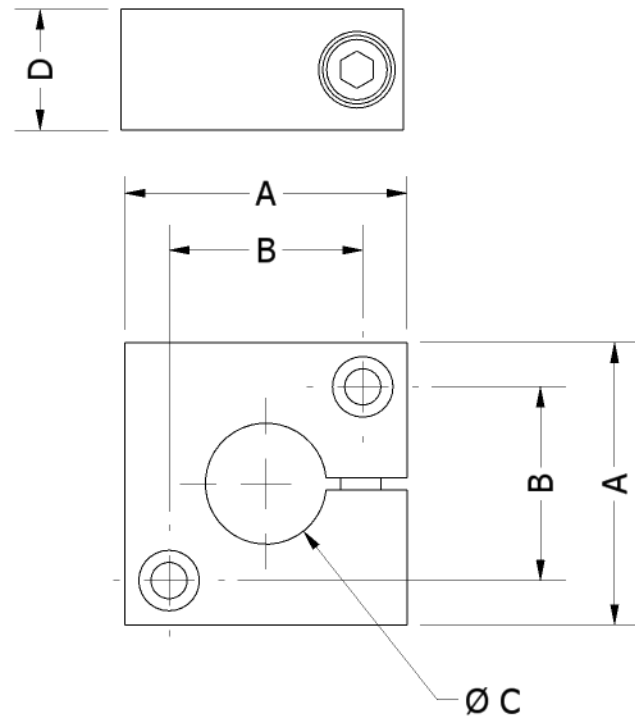
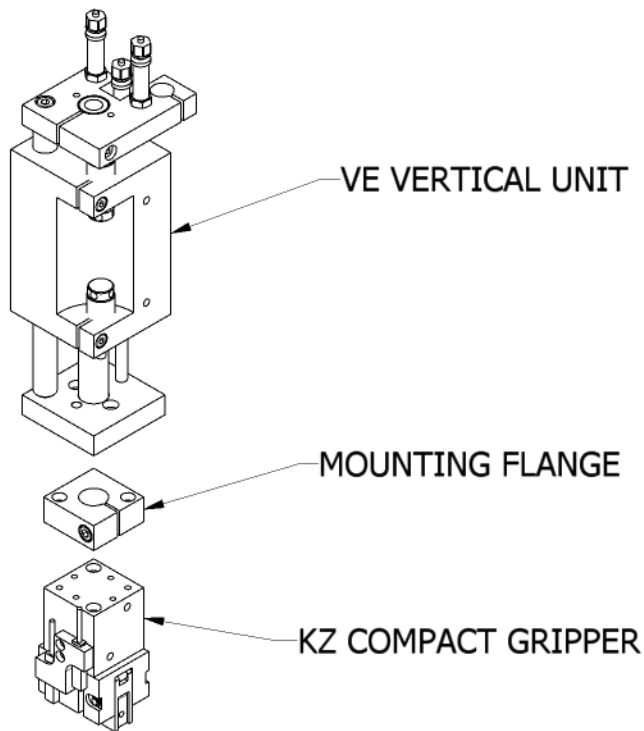

GRIPPER	A	B	C	D	ORDER NO.
...12	28	20	15-H7	12	ZB.08.010
...20	35	24	15-H7	15	ZB.08.001
...25	40	30	15-H7	15	ZB.08.002
...32	60	40	15-H7	15	ZB.08.003
...50	70	50	15-H7	15	ZB.08.008

# Angular Gripper KZ

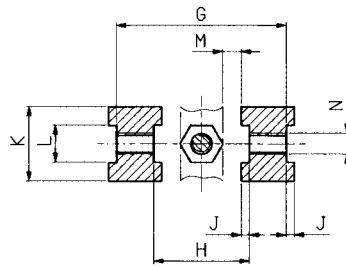
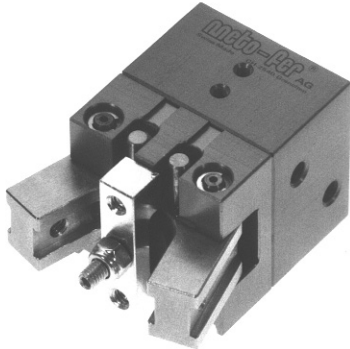

Section A-A

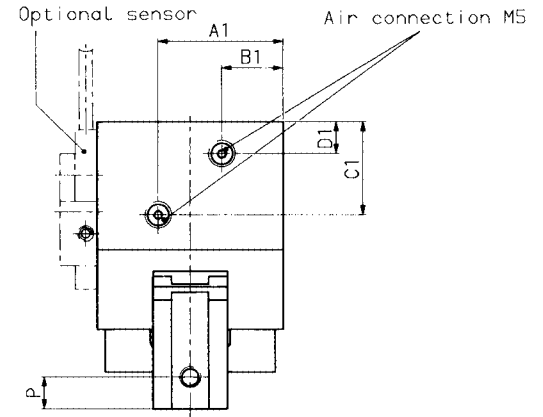
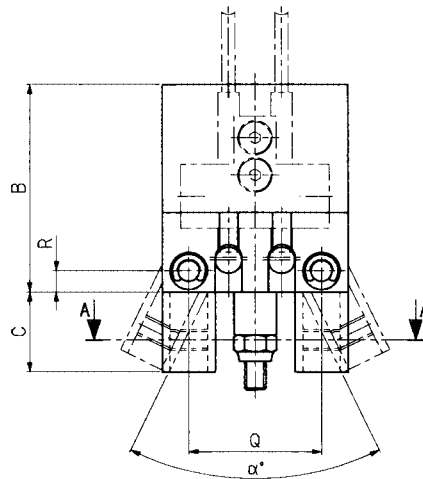
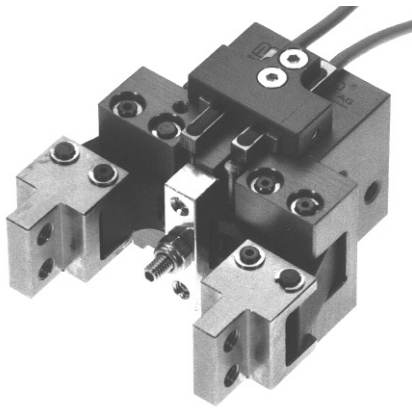
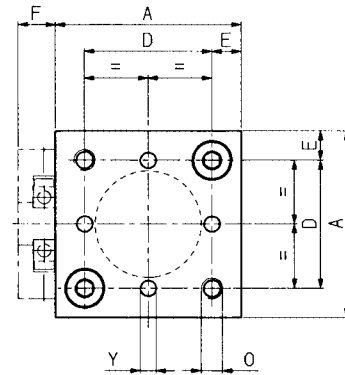

Mounting flange for KZ see sheet 4.013

Dimensions for air connections				
Type	A1	B1	C1	D1
KZ 12	18.25	9.75	14.5	6
KZ 20	23.5	11.5	17.5	6
KZ 25	26	14	19.5	5
*KZ 32	30	30	34	8
*KZ 50	35	35	33	8

Type	Clamping force at 72.5 psi (5 bar)	Air consumption for each double stroke at 5 bar	Weight
KZ 12	4 lb (19 N)	.0002 scf (0.004 NL)	0.3 lb (0.12 kg)
KZ 20	7 lb (30 N)	.0005 scf (0.014 NL)	0.6 lb (0.25 kg)
KZ 25	11 lb (48 N)	.0010 scf (0.027 NL)	0.8 lb (0.35 kg)
KZ 32	19 lb (85 N)	.0025 scf (0.072 NL)	2.4 lb (1.10 kg)
KZ 50	49 lb (220 N)	.0079 scf (0.224 NL)	3.6 lb (1.65 kg)

\*for these types, the dimensions A1 & B1 are equal

Type	A	B	C	D	E	F	G	H	J	K	L	M	N	O	P	Q	R	Y	$\alpha$
KZ12	28	31.5	14.5	20	4	7	25	16	1.5	12	6-H7	3	M3	M4/8	5	20	3.5	$\emptyset$ 2-EF7/5	52°
KZ20	35	39	15	24	5.5	7	32	18	1.5	14	7-H7	3.5	M4	M4/12	6	25	4	$\emptyset$ 3-EF7/5	52°
KZ25	40	44	20	30	5	7	37	23	1.5	14	7-H7	5	M4	M5/15	8	30	4	$\emptyset$ 4-EF7/5	58°
KZ32	60	72	32	40	10	8	56	32	2	25	12-H7	9	M6	M6/15	10	45	7	$\emptyset$ 5-EF7/4	56°
KZ50	70	72	40	50	10	8	66	38	2	30	15-H7	9.5	M6	M8/17	15	55	9	$\emptyset$ 5-EF7/4	60°

**Order No.** KZ12 KZ20 KZ25 KZ32 KZ50 without sensor bracket  
 KZ12D KZ20D KZ25D KZ32D KZ50D D = with sensor bracket  
 (IM... sensors not included)

**Order No.** KZ12D KZ25D KZ25D **Order No.** KZ32D KZ50D  
 (Sensors) IM-004-NS-U2L (NPN) (Sensors) IM-006-NS-U2L (NPN)  
 IM-004-PS-U2L (PNP) IM-006-PS-U2L (PNP)

## Technical data:

- Operating medium Compressed air oiled/ not oiled
- Operating pressure 43.5 - 116 psi (3 - 8 bar)
- Air connection M5
- Sensor option: Two IM...proximity sensors...gripper open/ gripper closed

# Semi-Parallel Gripper KZP

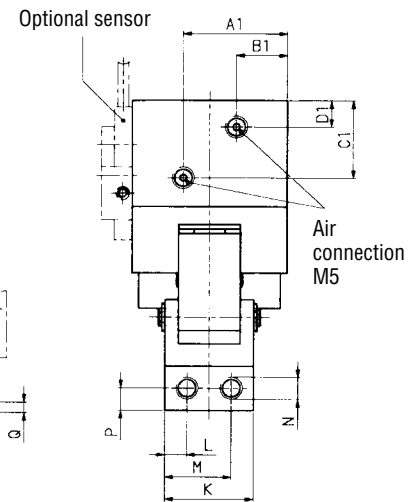
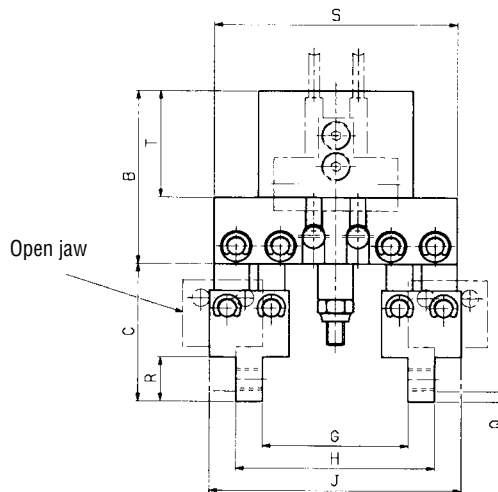
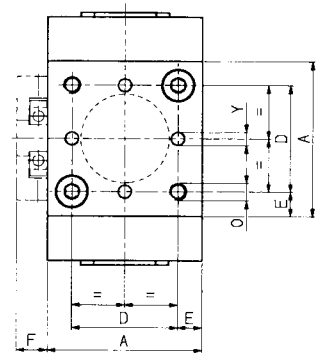
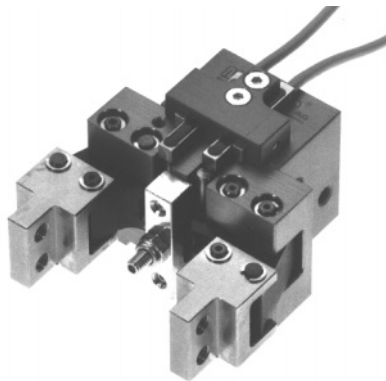
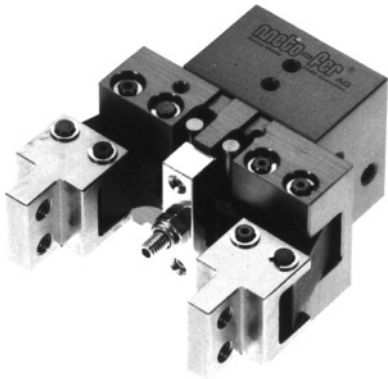

Mounting flange for KZP see sheet 4.013

Dimensions for air connections				
Type	A1	B1	C1	D1
KZP 12	18.25	9.75	14.5	6
KZP 20	23.5	11.5	17.5	6
KZP 25	26	14	19.5	5
*KZP 32	30	30	34	8
*KZP 50	35	35	33	8

Type	Clamping force at 72.5 psi (5 bar)	Air consumption for each double stroke at 5 bar	Weight
KZP 12	4 lb (19 N)	.0002 scf (0.004 NL)	0.4 lb (0.18 kg)
KZP 20	7 lb (30 N)	.0005 scf (0.014 NL)	0.7 lb (0.30 kg)
KZP 25	11 lb (48 N)	.0010 scf (0.027 NL)	1.0 lb (0.45 kg)
KZP 32	19 lb (85 N)	.0025 scf (0.072 NL)	3.7 lb (1.70 kg)
KZP 50	49 lb (220 N)	.0079 scf (0.224 NL)	5.1 lb (2.30 kg)

\*For these types, the dimensions A1 & B1 are equal.

Type	A	B	C	D	E	F	G min.	G max.	H min.	H max.	J min.	J max.	K	L	M	N	O	P	Q	R	S	T	Y
KZP12	28	31.5	20.5	20	4	7	22.5	31	33.5	42	41.5	50	17	3.5	13.5	M4	M4/8	4	1.1	8	41	19.5	ø2-EF7/5
KZP20	35	39	31	24	5.5	7	33	45	45	57	57	69	20	5	15	M5	M4/12	5	2.3	10	55	24	ø3-EF7/5
KZP25	40	44	31	30	5	7	38	51.5	50	63.5	62	75.5	20	5	15	M5	M5/15	5	2.7	10	60	28	ø4-EF7/5
KZP32	60	72	49	40	10	8	47	68	75	96	95	116	35	10	25	M6	M6/15	7.5	2.7	15	95	44	ø5-EF7/4
KZP50	70	72	47	50	10	8	50	74	82	106	102	126	40	10	30	M6	M8/17	7.5	3	15	105	42	ø5-EF7/4

**Order No.** KZP12 KZP20 KZP25 KZP32 KZP50 without sensor bracket  
 KZP12D KZP20D KZP25D KZP32D KZP50D D = with sensor bracket  
 (IM... sensors not included)

**Order No.** KZP12D KZP20D KZP25D **Order No.** KZP32D KZP50D  
 (Sensors) IM-004-NS-U2L (NPN) (Sensors) IM-006-NS-U2L (NPN)  
 IM-004-PS-U2L (PNP) IM-006-PS-U2L (PNP)

## Technical data:

- Operating medium Compressed air oiled/ not oiled
- Operating pressure 43.5 - 116 psi (3 - 8 bar)
- Air connection M5
- Sensor option: Two IM...proximity sensors...gripper open/ gripper closed

# 180° Angular Gripper KZ 180

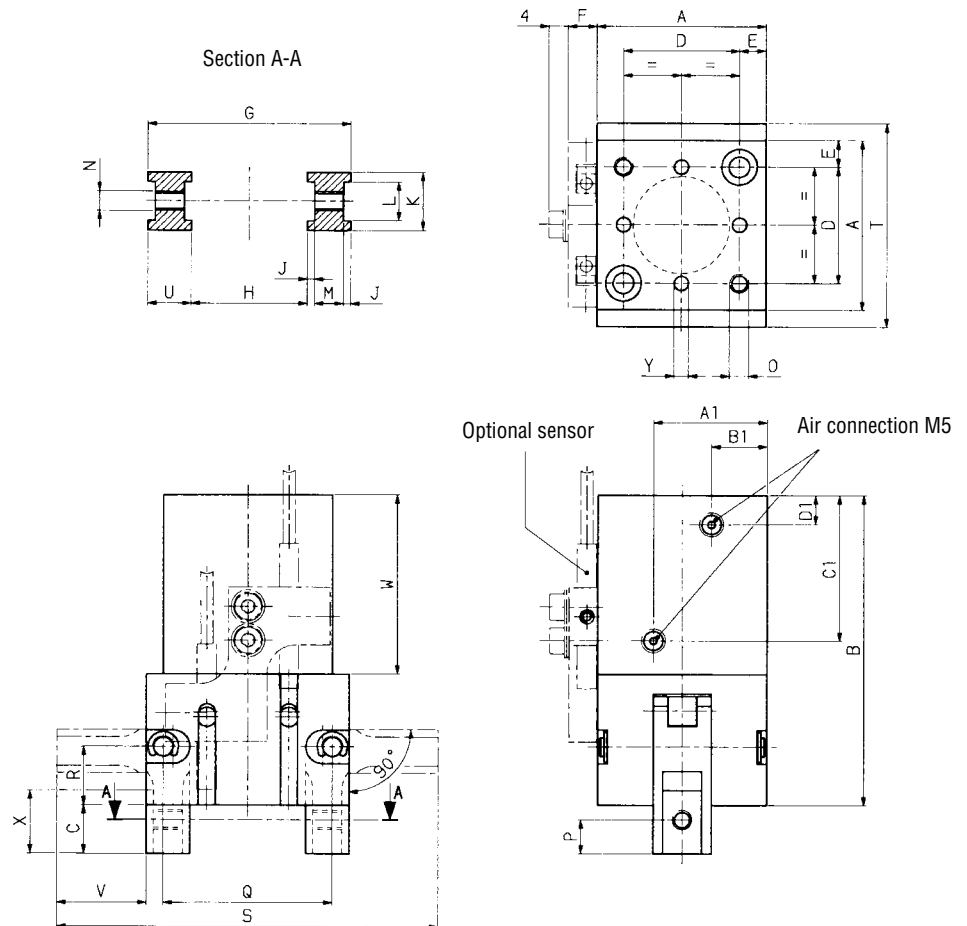
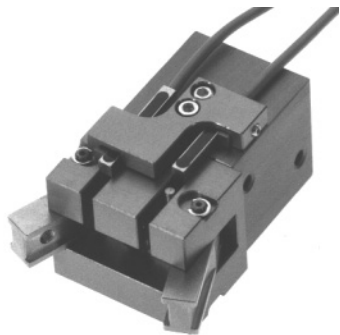
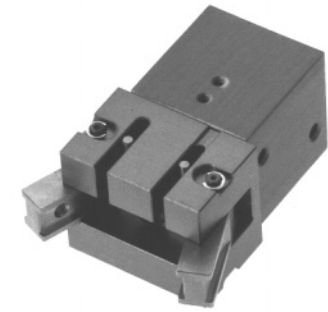

Mounting flange for KZ 180 see sheet 4.013

Dimensions for air connections				
Type	A1	B1	C1	D1
KZ 180/12	18.25	9.75	24.5	6
KZ 180/20	23.5	11.5	30	6
KZ 180/25	26	14	35	5
*KZ 180/32	30	30	50.5	7.2
*KZ 180/50	35	35	58.5	8.5

\*for these types, the dimensions A1 & B1 are equal

Type	Clamping force at 72.5 psi (5 bar)	Air consumption for each double stroke at 5 bar	Weight
KZ 180/12	4 lb (16 N)	.0006 scf (0.016 NL)	0.3 lb (0.15 kg)
KZ 180/20	11 lb (49 N)	.0022 scf (0.063 NL)	0.7 lb (0.30 kg)
KZ 180/25	20 lb (87 N)	.0038 scf (0.108 NL)	1.0 lb (0.45 kg)
KZ 180/32	30 lb (135 N)	.0095 scf (0.269 NL)	2.6 lb (1.25 kg)
KZ 180/50	65 lb (291 N)	.0276 scf (0.782 NL)	4.5 lb (2.05 kg)

Type	A	B	C	D	E	F	G	H	J	K	L	M	N	O	P	Q	R	S	T	U	V	W	X	Y
KZ180/12	28	52	10	20	4	6	30	18	1	12	8-H7	4	M4	M4/8	5	25	9	63	30	6	16	29.5	10.5	ø2-EF7/5
KZ180/20	35	64	10	24	5.5	6	42	24	1.5	12	8-H7	6	M4	M4/12	7	35	12	79	42	9	18.5	37	13	ø3-EF7/5
KZ180/25	40	76.5	13	30	5	6	47	29	1.5	14	10-H7	6	M5	M5/15	8	40	13.5	93	50	9	21.5	43.5	15	ø4-EF7/5
KZ180/32	60	108.5	20	40	10	8	65	39	2	25	12-H7	9	M6	M6/15	10	55	20	135	68	13	33.5	59.5	24	ø5-EF7/4
KZ180/50	70	125.5	33	50	10	8	77	47	2.5	30	15-H7	10	M6	M8/17	15	65	23.5	178	80	15	49	67.5	35	ø5-EF7/4

<b>Order No.</b>	KZ180/12	KZ180/20	KZ180/25	KZ180/32	KZ180/50	without sensor bracket
	KZ180/12D	KZ180/20D	KZ180/25D	KZ180/32D	KZ180/50D	D = with sensor bracket
<b>Order No.</b>	KZ180/12D	KZ180/20D	KZ180/25D			(IM... sensors not included)
(Sensors)	IM-004-NS-U2L (NPN)					
	IM-004-PS-U2L (PNP)					
<b>Order No.</b>				KZ180/32D	KZ180/50D	
(Sensors)				IM-006-NS-U2L (NPN)	IM-006-PS-U2L (PNP)	

## Technical data:

- Operating medium: Compressed air oiled/ not oiled
- Operating pressure: 43.5 - 116 psi (3 - 8 bar)
- Air connection: M5
- Sensor option: Two IM...proximity sensors...gripper open/ gripper closed

# Parallel Gripper KZL

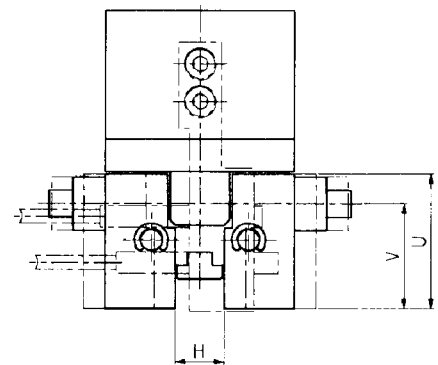
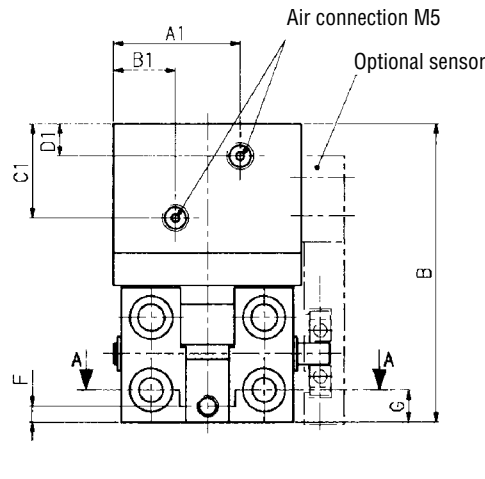
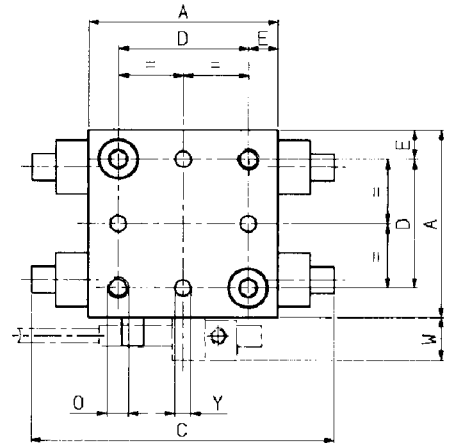
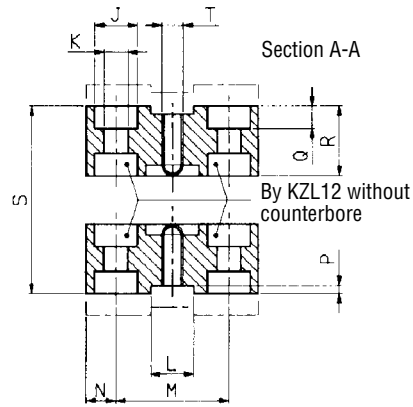
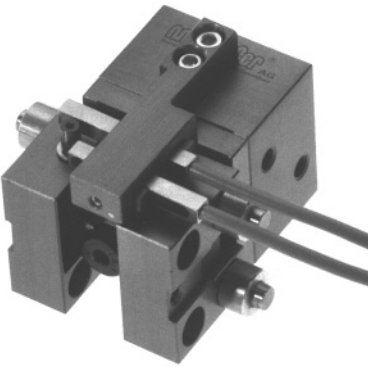
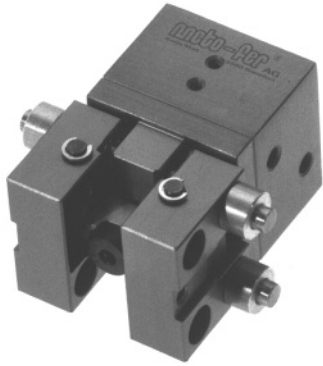

Mounting flange for KZL see sheet 4.013

Dimensions for air connections				
Type	A1	B1	C1	D1
KZL 12	18.25	9.75	14.5	6
KZL 20	23.5	11.5	17.5	6
KZL 25	26	14	19.5	5
*KZL 32	30	30	34	8
*KZL 50	35	35	33	8

\*for these types, the dimensions A1 & B1 are equal

Type	Clamping force at 72.5 psi (5 bar)	Air consumption for each double stroke at 5 bar	Weight
KZL 12	7 lb (31 N)	.0002 scf (0.004 NL)	0.3 lb (0.15 kg)
KZL 20	20 lb (88 N)	.0005 scf (0.014 NL)	0.4 lb (0.20 kg)
KZL 25	31 lb (137 N)	.0010 scf (0.027 NL)	0.8 lb (0.35 kg)
KZL 32	51 lb (225 N)	.0025 scf (0.072 NL)	2.1 lb (0.95 kg)
KZL 50	124 lb (550 N)	.0079 scf (0.224 NL)	3.3 lb (1.50 kg)

Type	A	B	C	D	E	F	G	H min.	H max.	J	K	L	M	N	O	P	Q	R	S min.	S max.	T	U	V	W	Y
KZL12	28	49.5	48	20	4	7.5	7.5	8	15	6	3.5	6-H7	17	5.5	M4/8	1.2	3.2	10	28	35	M3	25	20	8	ø2-EF7/5
KZL20	35	55.5	56	24	5.5	3	6	9.5	17.5	8	4.5	8-H7	21	5.5	M4/12	1.5	4.2	13	35.5	43.5	M4	25	19.5	8	ø3-EF7/5
KZL25	40	65.5	60	30	5	4	7	10	20	8	4.5	10-H7	26	5.2	M5/15	1.5	4.2	15	40	50	M5	30	22.5	8	ø4-EF7/5
KZL32	60	87.5	90	40	10	8	8	15	31	10	5.5	12-H7	28	14	M6/15	2.5	5.2	22.5	60	76	M6	35	26.5	9.5	ø5-EF7/4
KZL50	70	102	107	50	10	16	16	20	40	11	6.6	15-H7	40	13	M8/17	2.5	6.2	25	70	90	M6	50	39	9.5	ø5-EF7/4

**Order No.** KZL12 KZL20 KZL25 KZL32 KZL50 without sensor bracket  
 KZL12D KZL20D KZL25D KZL32D KZL50D D = with sensor bracket  
 (IM... sensors not included)

**Order No.** KZL12D KZL20D KZL25D **Order No.** KZL32D, KZL50D  
 (Sensors) IM-004-NS-U2L (NPN) (Sensors) IM-006-NS-U2L (NPN)  
 IM-004-PS-U2L (PNP) IM-006-PS-U2L (PNP)

## Technical data:

- Operating medium Compressed air oiled/ not oiled
- Operating pressure 43.5 - 116 psi (3 - 8 bar)
- Air connection M5
- Sensor option: Two IM...proximity sensors... gripper open / gripper closed



# Three Finger Angular Gripper KZ3

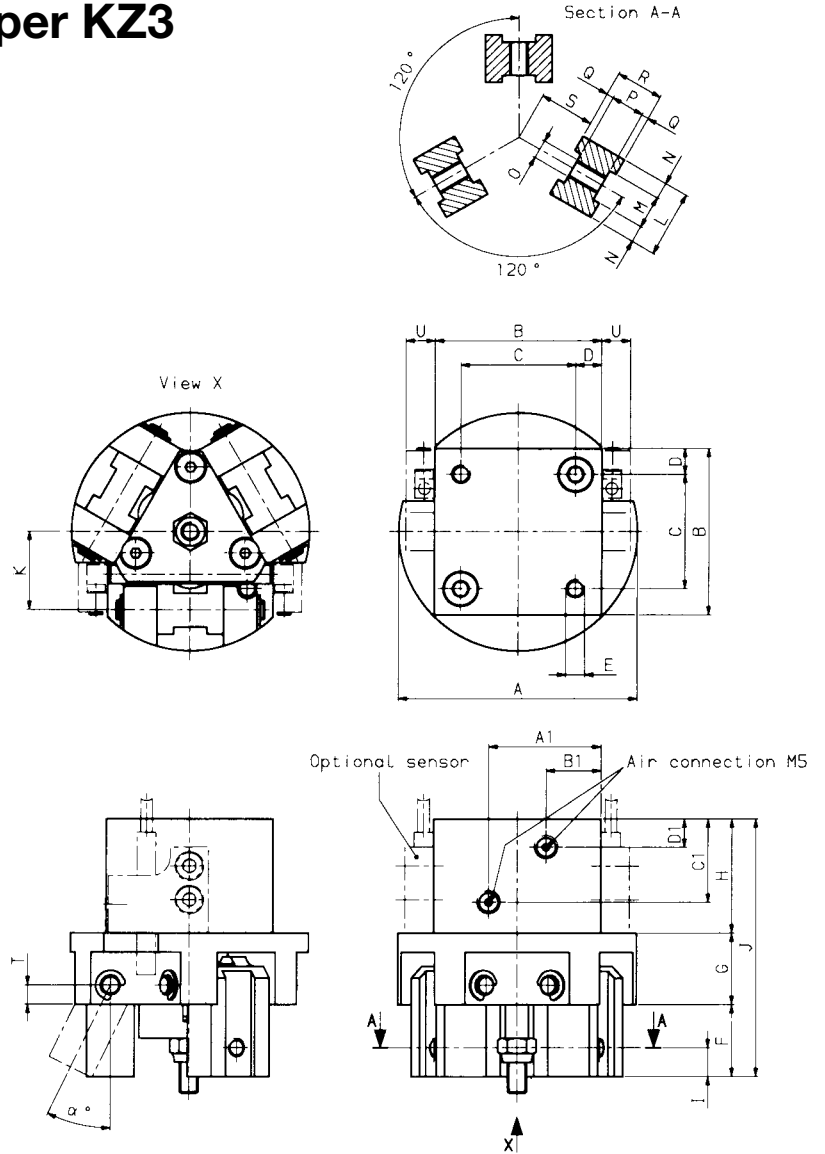
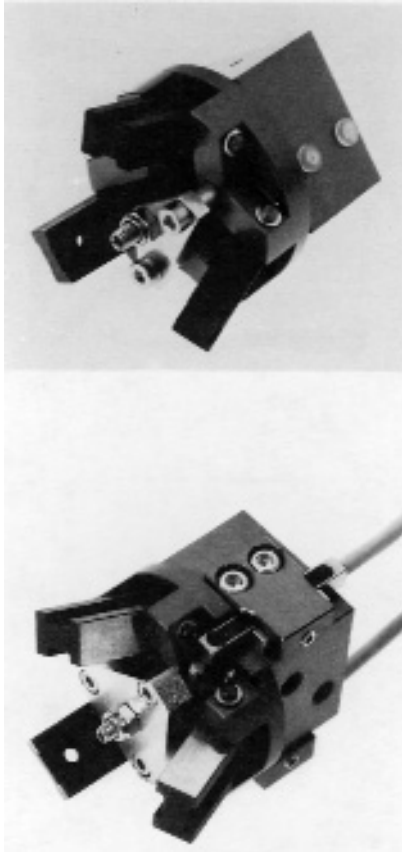

Mounting flange for KZ3 see sheet 4.013

Dimensions for air connections				
Type	A1	B1	C1	D1
KZ 3/12	18.25	9.75	14.5	6
KZ 3/20	23.5	11.5	17.5	6
KZ 3/25	26	14	19.5	5
*KZ 3/32	30	30	34	8
*KZ 3/50	35	35	33	8

\*for these types, the dimensions A1 & B1 are equal

Type	Clamping force at 72.5 psi (5 bar)	Air consumption for each double stroke at 5 bar	Weight
KZ 3/12	4 lb (19 N)	.0002 scf (0.004 NL)	0.3 lb (0.15 kg)
KZ 3/20	7 lb (30 N)	.0005 scf (0.014 NL)	0.6 lb (0.25 kg)
KZ 3/25	11 lb (48 N)	.0010 scf (0.027 NL)	0.9 lb (0.40 kg)
KZ 3/32	19 lb (85 N)	.0025 scf (0.072 NL)	3.1 lb (1.40 kg)
KZ 3/50	49 lb (220 N)	.0079 scf (0.224 NL)	4.4 lb (2.00 kg)

Type	A	B	C	D	E	F	G	H	I	J	K	L	M	N	O	P	Q	R	S	T	U	$\alpha$
KZ 3/12	40	28	20	4	M4/8	14.5	12	19.5	5	46	13.5	12	6-H7	3	M3	4.5	1.5	7.5	10	3.5	6	26°
KZ 3/20	50	35	24	5.5	M4/12	15	15	24	6	54	16.5	14	7-H7	3.5	M4	7	1.5	10	11.5	4	6	26°
KZ 3/25	55	40	30	5	M5/15	20	16	28	8	64	19.5	14	7-H7	3.5	M4	7	1.5	10	14.5	4	6	29°
KZ 3/32	90	60	40	10	M6/15	32	28	44	10	104	30	25	12-H7	6.5	M6	12	2	16	21.5	7	8	28°
KZ 3/50	100	70	50	10	M8/17	40	30	42	15	112	36	30	15-H7	7.5	M6	14	2	18	25.5	9	8	30°

**Order No.** KZ3/12 KZ3/20 KZ3/25 KZ3/32 KZ3/50 without sensor bracket  
 KZ3/12D KZ3/20D KZ3/25D KZ3/32D KZ3/50D D = with sensor bracket  
 (IM... sensors not included)

**Order No.** KZ3/12D KZ3/20D KZ3/25D **Order No.** KZ3/32D KZ3/50D  
 (Sensors) IM-004-NS-U2L (NPN) (Sensors) IM-006-NS-U2L (NPN)  
 IM-004-PS-U2L (PNP) IM-006-PS-U2L (PNP)

**Technical data:**

- Operating medium Compressed air oiled/ not oiled
- Operating pressure 43.5 - 116 psi (3 - 8 bar)
- Air connection M5
- Sensor option: Two IM...proximity sensors... gripper open / gripper closed

**ACCESSORIES**

**SECTION 5**



**Your complete source for industrial automation and electronics**

**mf automation, inc.**

[www.meto-fer.com](http://www.meto-fer.com)

1-888-638-6337

# Elastomer cushion KB

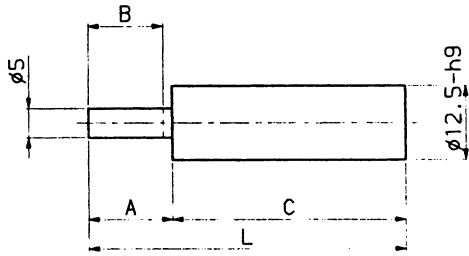

Type	A	B	C	L	Force KE Lb. in (Nm)	Weight ounces (g)	Order No.
KB07/12.5	7	6.5	39	46	17.7 (2.0)	0.78 (22)	KB07/12.5
KB08/12.5	7	6.5	34	41	17.7 (2.0)	0.71 (20)	KB08/12.5
KB14/12.5	14	12.5	39	53	39.8 (4.5)	0.82 (23)	KB14/12.5

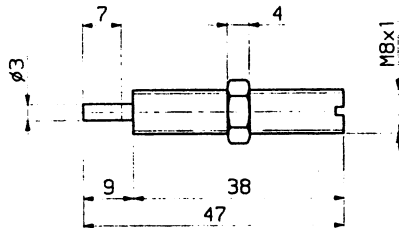

Type	Force KE Lb. in (Nm)	Weight ounces (g)	Order No.
KB06	17.7 (2.0)	0.32 (g)	KB06

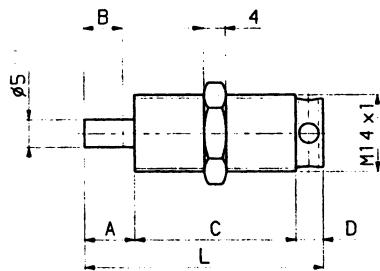

Type	A	B	C	D	L	Force KE Lb. in (Nm)	Weight ounces (g)	Order No.
KB07	9	7	29	5	43	39.8 (4.5)	0.96 (27)	KB07
KB08	14	12.5	43	7	64	39.8 (4.5)	1.42 (40)	KB08



KOB 50

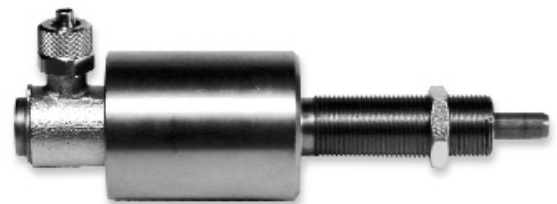

OB 12/20



OB 15/10K and OB 15/10L

The oil cushions are intended to absorb the kinetic energy of a moving mass and arrest the momentum in a progressive manner. They provide stable motion of slide ways and rotary units by bringing them to a gentle stop without undue wear on the stops. The oil cushion should be adjusted such that it is not used as the final stop, only the stop screws are designed for this purpose.

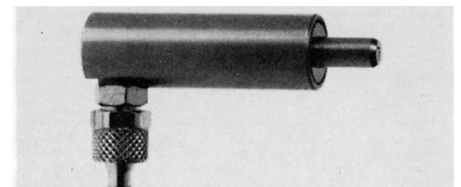

OB 9/10 and OB 10/10

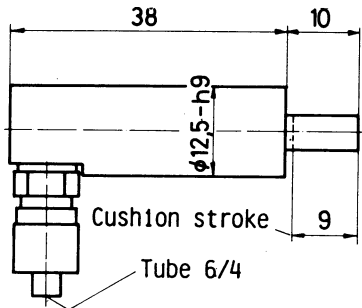

Order No. OB 9/10

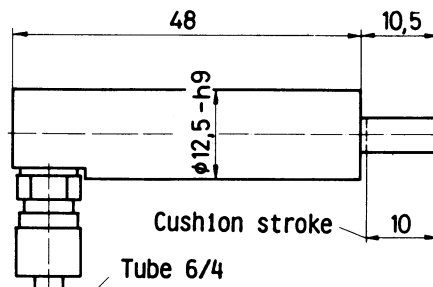

Order No. OB 10/10

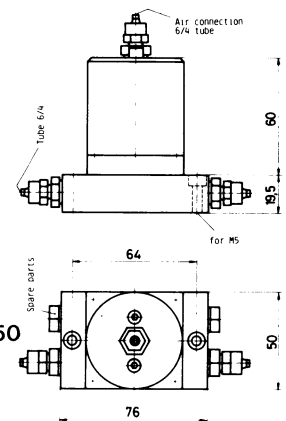

Order No. KOB 50

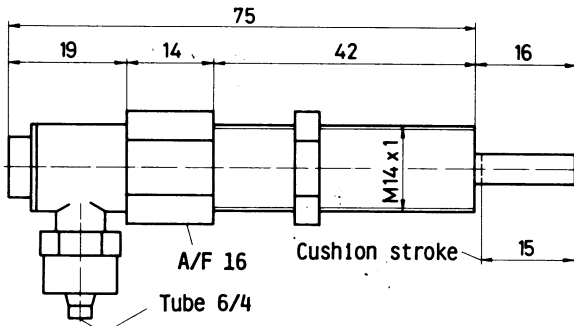

Order No. OB 15/10 K

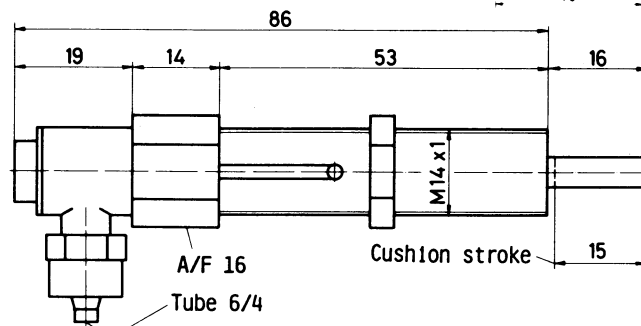

Order No. OB 15/10 L

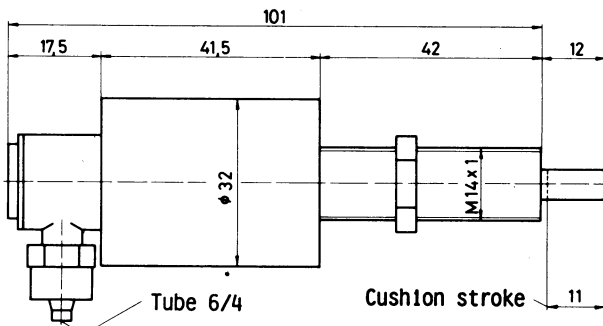

Order No. OB 12/20

Installation of the oil cushion in the cylinder

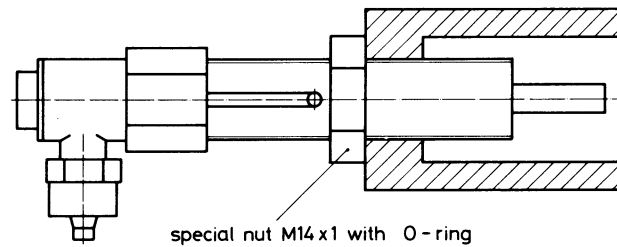

Order No. MU 01.008

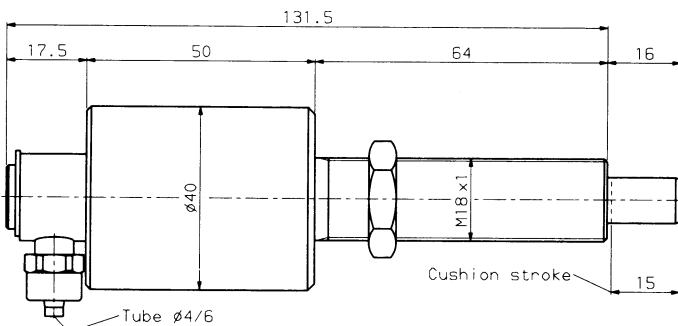

Order No. OB 15/20

**Note:** The cushion must not be used as a final stop.

**Function of the cushion**

The cushion is like a hydraulic cylinder with a built in one way restrictor. It is charged with oil from the compensating reservoir. When a mass approaches and depresses the piston rod the oil is displaced through an orifice plate which reduces progressively with the movement. The displaced oil returns to the reservoir at high speed. The reservoir must not be filled more than half full. Use light hydraulic oil. Ensure all trapped air is expelled from the cushion by cycling. An air supply of 43.5–87.0 psi (3–6 bar) must be connected to the top of the reservoir to keep the cushions charged. Provision is made for up to 4 cushions to be connected, more may be connected provided the kinetic energy generated does not cause over heating. The only adjustment is by varying the point of initial contact. The mounting clamp must be robust and able to absorb three times the power of the cushion. (Momentum =  $Ke / \text{stop distance}$ ). Collision speed should be 0,4–3,8 m/s.

Type	Momentum KE/s in lb (N)	Force KE in lb. in (Nm)	Max. No. double strokes per min	Max. output in Watt
OB 9/10	31 – 540 (140–2400)	13.28 – 194.70 (1,5–22)	240	90
OB 10/10	31 – 540 (140–2400)	13.28 – 194.70 (1,5–22)	240	90
OB 15/10 K	31 – 618 (140–2750)	13.28 – 265.50 (1,5–30)	240	120
OB 15/10 L	31 – 618 (140–2750)	13.28 – 265.50 (1,5–30)	240	120
OB 12/20	90 – 1349 (400–6000)	39.83 – 619.50 (4,5–70)	180	210
OB 15/20	90 – 2023 (400–9000)	39.83 – 929.25 (4,5–105)	90	315

## Suction cups

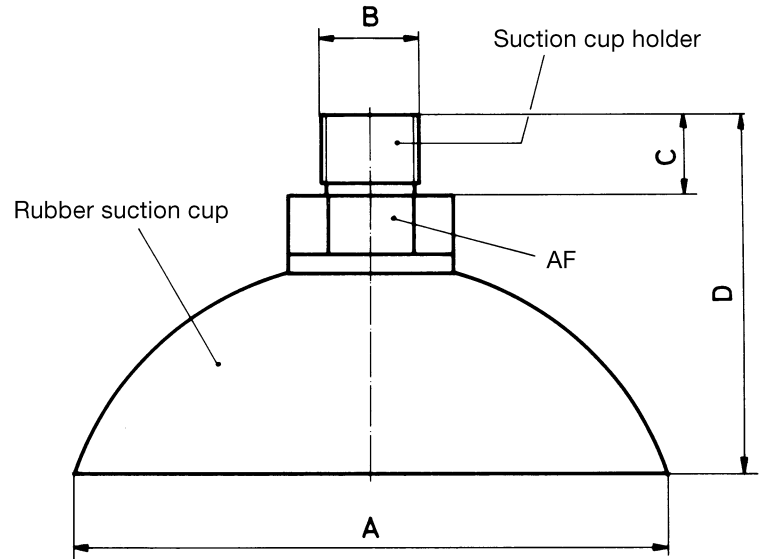

Type	A (mm)	B (mm)	C (mm)	D (mm)	AF (mm)	Suction force	Cup only Order No.	Suction cup holder Order No.	Complete Order No.
VA 10.06	6	M5	6	18	8	.2 lb (0,7 N)	VA-SN-06	VA 03.001	VA-SK-06
VA 10.08	8	M5	6	19	8	.3 lb (1,2 N)	VA-SN-08	VA 03.002	VA-SK-08
VA 10.12	12	M5	6	23	10	.6 lb (2,8 N)	VA-SN-12	VA 03.003	VA-SK-12
VA 10.15	15	M5	6	24	10	1.0 lb (4,4 N)	VA-SN-15	VA 03.003	VA-SK-15
VA 10.18	18	M5	6	24	10	1.4 lb (6,3 N)	VA-SN-18	VA 03.003	VA-SK-18
VA 10.22	22	M5	6	25	10	2.1 lb (9,5 N)	VA-SN-22	VA 03.003	VA-SK-22
VA 10.25	25	M5	6	28	10	2.8 lb (12,3 N)	VA-SN-25	VA 03.004	VA-SK-25
VA 10.30	30	M5	6	28	10	4.0 lb (17,6 N)	VA-SN-30	VA 03.004	VA-SK-30
VA 10.45	45	R½''	8	34	15	8.9 lb (39,8 N)	VA-SN-45	VA 03.007	VA-SK-45
VA 10.60	60	R½''	8	36	15	15.9 lb (70,6 N)	VA-SN-60	VA 03.007	VA-SK-60
VA 10.85	85	R½''	8	58	22	31.9 lb (141,8 N)	VA-SN-85	VA 03.010	VA-SK-85

Suction refers to components with a flat ground surface at max. vacuum of  $-10.2$  psi ( $-0,7$  bar).

### Technical data:

- Temperature range -4° to 158° F (-20° to 70° C)
- Oil-resistant yes
- Acid-resistant no
- Hardness 60 Shore
- Good mechanical properties

### Air filter (vacuum)

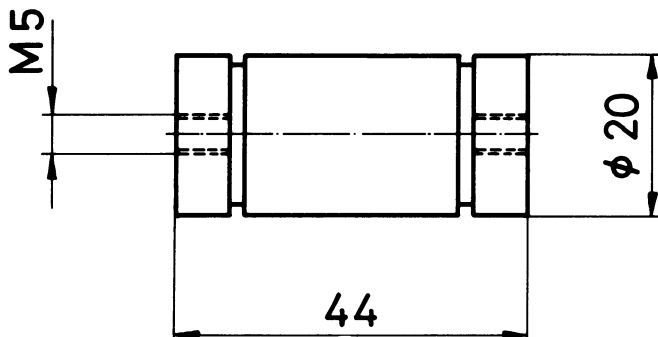

In locations where dirt particles can be picked up by vacuum generators it is recommended that a filter is used.

Replacement filter **Order No.** VA 06 E

## Flow control valve DV

Adjustable, with swivel connector



These valves are used to regulate exhaust airflow. For example: to control the piston on double-acting cylinders. An adjustment screw allows variable flow in one direction (arrow) and permits air to flow freely in the opposite direction. These space saving valves mount directly into the cylinder port. The body can be rotated 360° for optimum alignment.

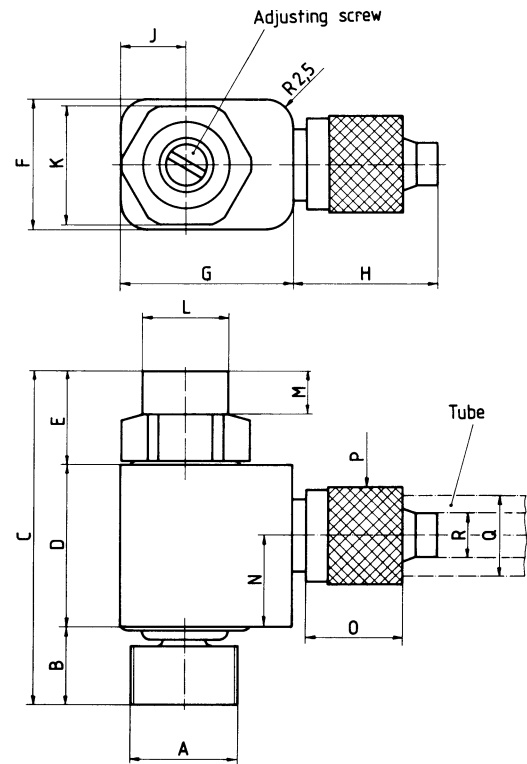

Type	Orifice	A	B	C	D	E	F	G	H	J	K	L	M	N	O	P	Q	R	Weight	Order No.
DV-M5	2.5	M5	5.5	29.5	15	9	14	17	13.5	7	11	8	4	8.5	9	9	6	4	.45 ounces (13 g)	DV-M5
DV-R $\frac{1}{8}$ "	2.5	R $\frac{1}{8}$ "	7	31	15	9	14	17	13.5	7	11	8	4	8.5	9	9	6	4	.55 ounces (15.5 g)	DV-R $\frac{1}{8}$ "
DV-R $\frac{1}{4}$ "	4	R $\frac{1}{4}$ "	9	44.5	20	15.5	18	18	16	9	15	11	8.5	12.5	10	14	8	6	1.45 ounces (41 g)	DV-R $\frac{1}{4}$ "

## Hand slide valve HV

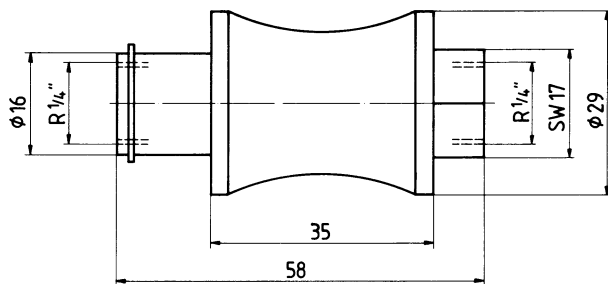

Order No. HV-R $\frac{1}{4}$ "

# X-Y Axis Alignment Slides (X-Y stage)

The X-Y Axis Alignment Slide has the advantage of one side operation for both axes. This is especially beneficial for use in small spaces. These X-Y slides are being used extensively in inkjet printers and other standard printer applications. Very fine adjustments are possible from one side by means of an adjusting screw, allowing adjustment in both directions as well as locking of the spindle.

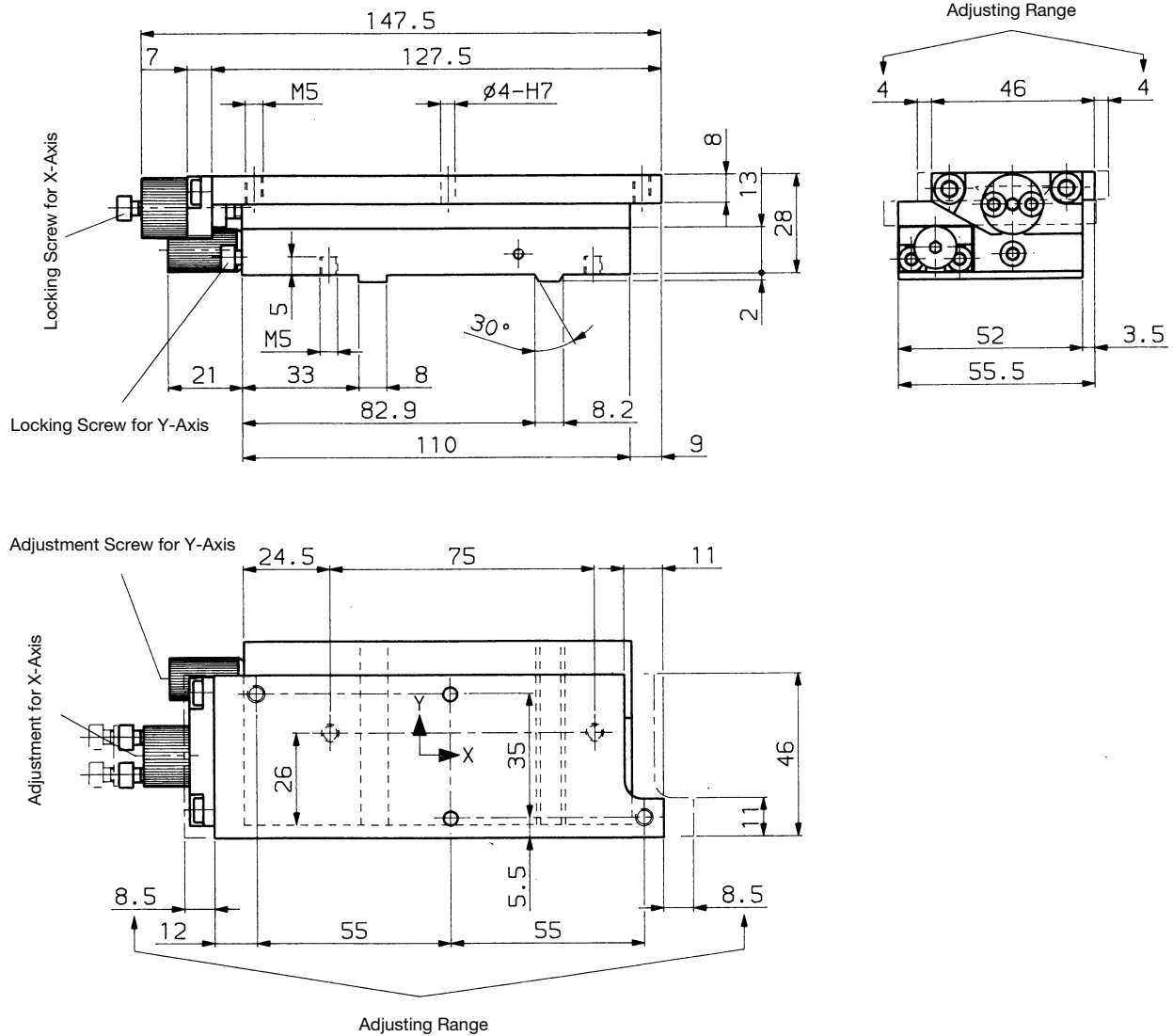

**Order No:** KK-8.5-4.0

**Adjusting Range:** X-Axis  $\pm 8.5$ mm    1mm per one revolution  
Y-Axis  $\pm 4.0$ mm    1mm per one revolution

**Max Load:** F=200N  
Mx=1.5Nm  
My=0.5Nm  
Mz=1.0Nm

**Angularity:** Z-Axis  $\pm 3^\circ$

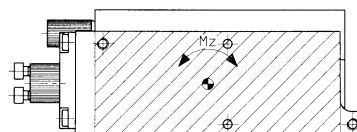
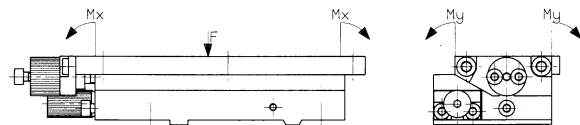

**STANDS & MODULAR MOUNTING BRACKETS & ADAPTER PLATES**

**SECTION 6**



**Your complete source for industrial automation and electronics**

**mf automation, inc.**

[www.meto-fer.com](http://www.meto-fer.com)

1-888-638-6337



# Stands and Modular Mounting Brackets and Adapter Plates

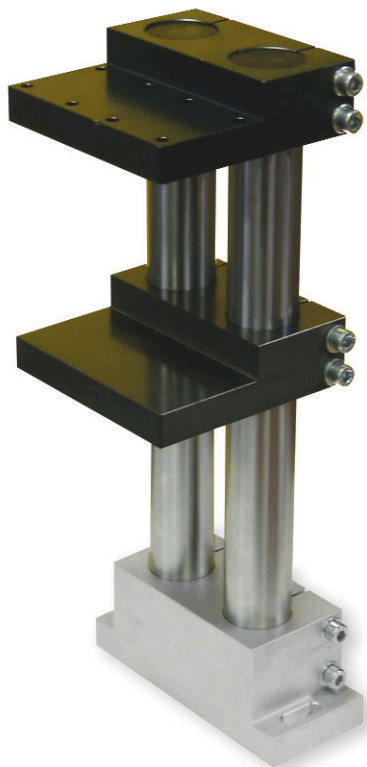

To achieve peak operation of precise, dynamic handling systems, a robust, vibration resistant supporting structure is essential. Only with such a structure is it possible to exploit the high repeat accuracies and speeds of the individual elements.

Our ground, chromium plated single and double columns allow precise, simple clamping and adjustment of mounting plates and transverse connectors. Through the use of these standard modular components, a wide range of mounting arrangements can be easily configured.

## Product features:

- Chrome-Plated Shafting, diameter 40 mm
- Standard Lengths or custom lengths available
- Simple, Precise and Secure
- Easy height adjustment
- No need to design; use standard modular assembly blocks
- Precision components
- Grey anodized mounting blocks  
Order 20 pc. or more choose your color; black, red, green, blue, purple, or gold)

## Application:

SE01.002

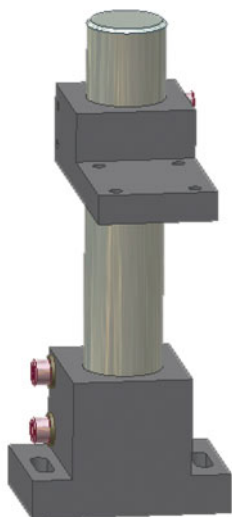

SE01.001

SE01.010

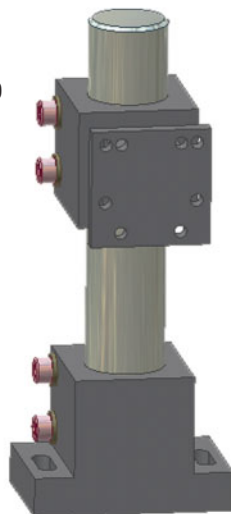

SE01.001

SD01.002

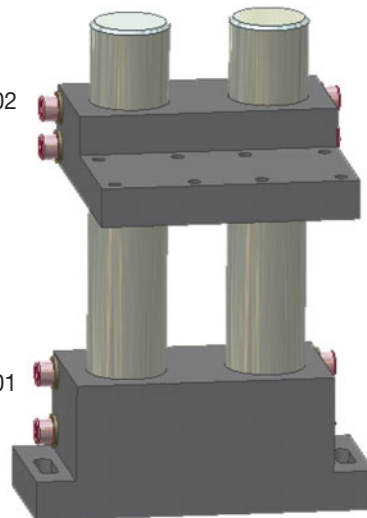

SD01.001



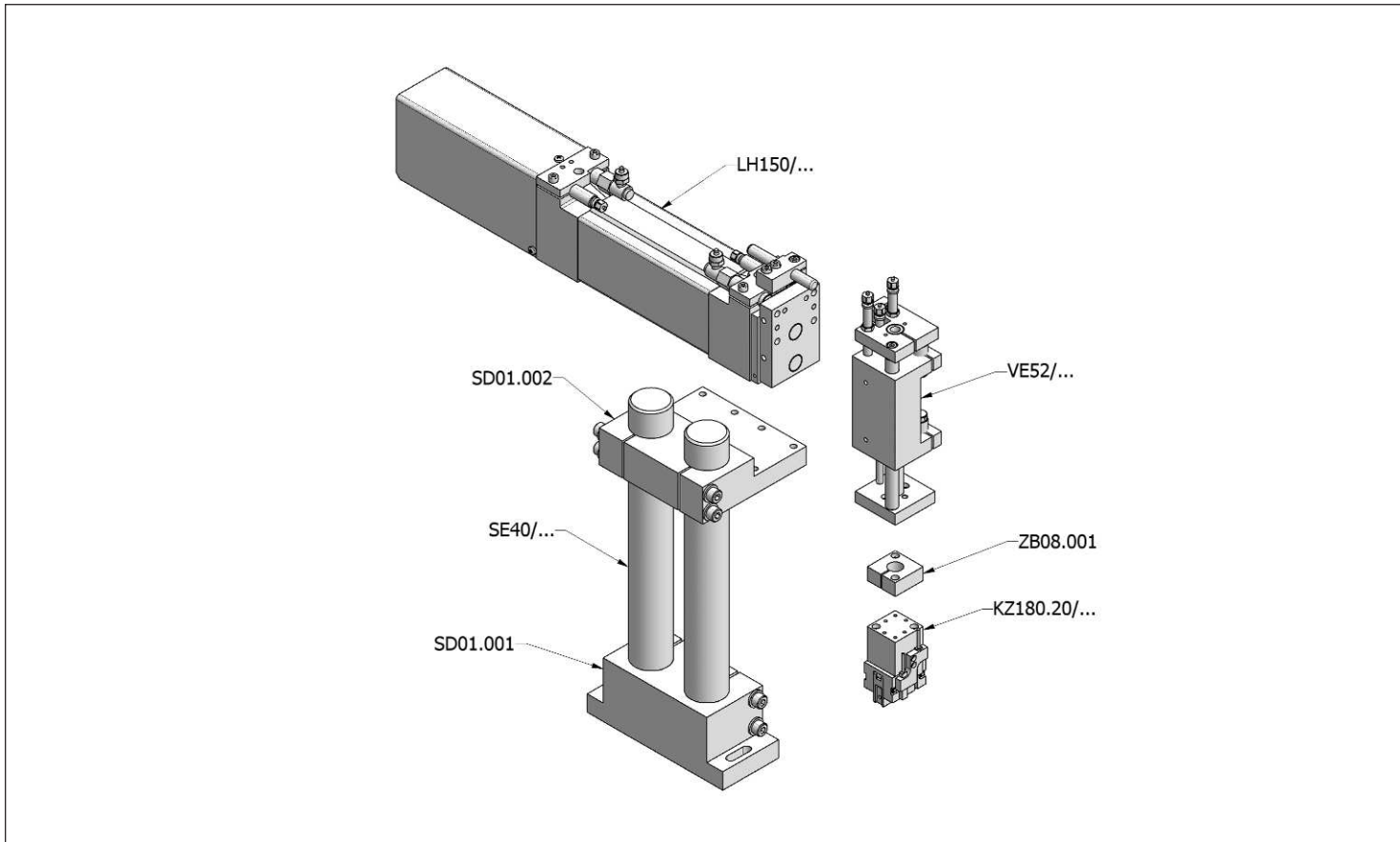
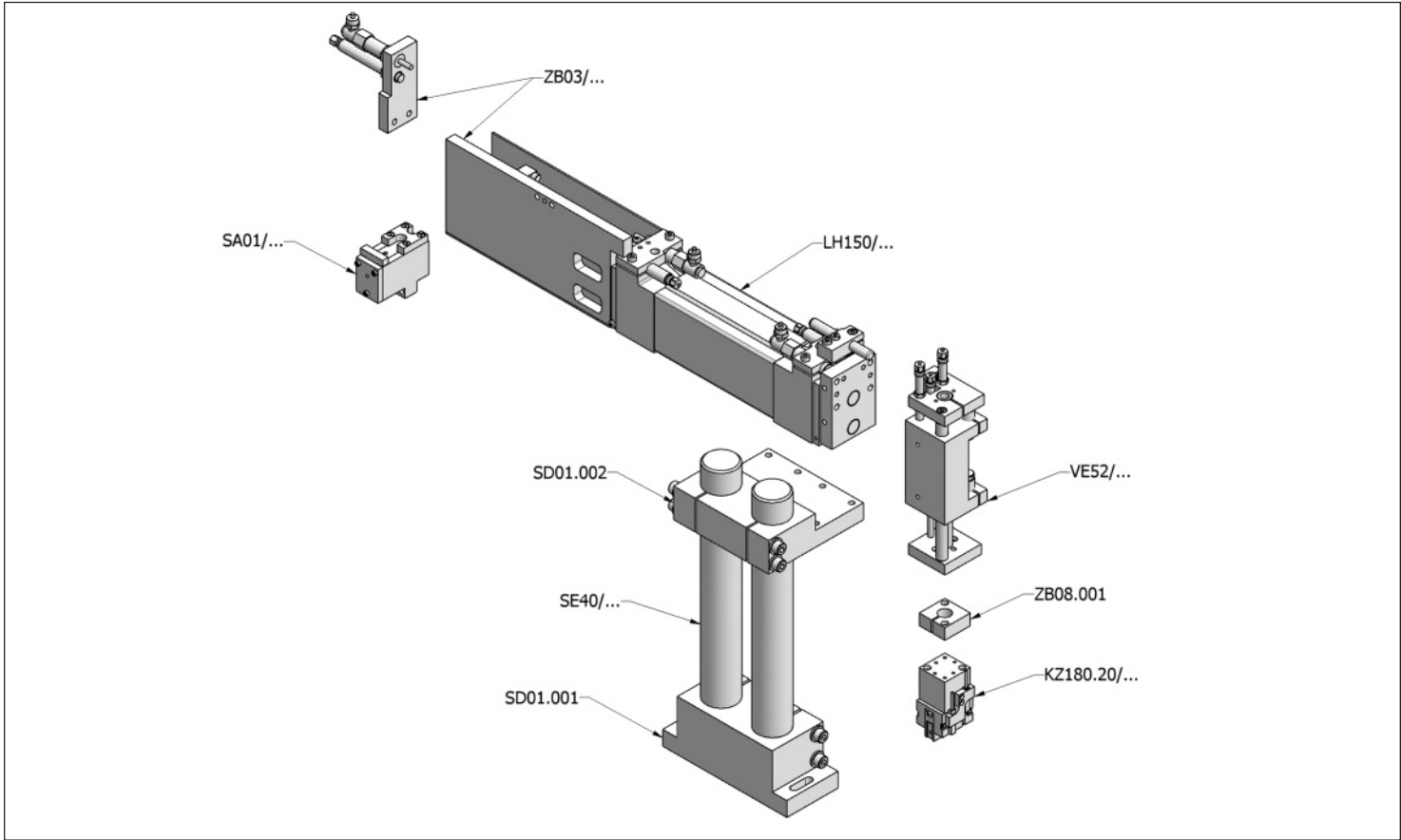

# Stands and Mounting Brackets – Examples of Application

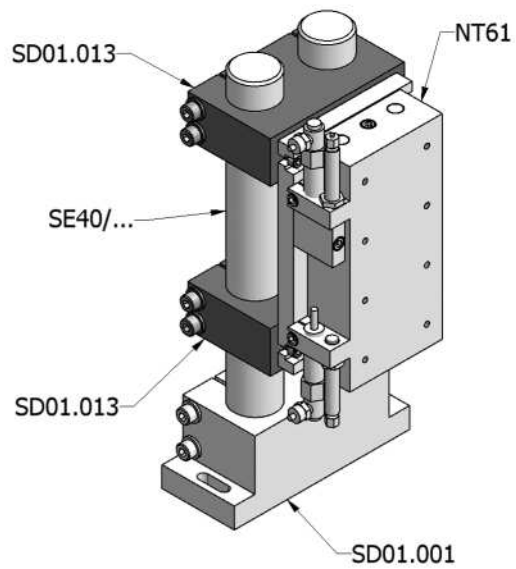
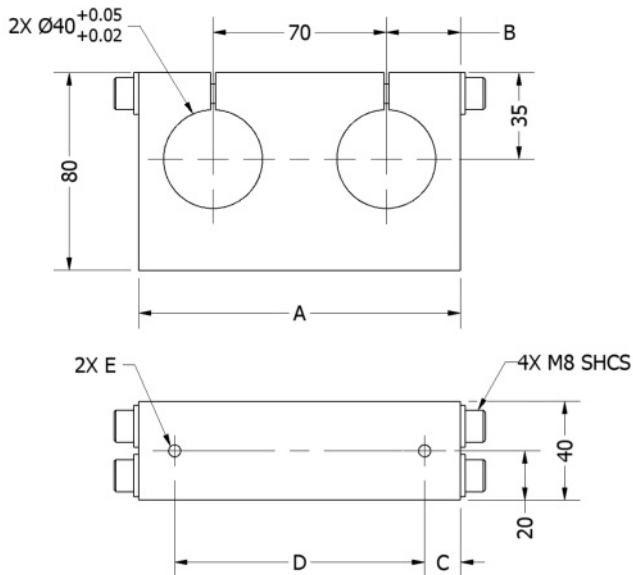
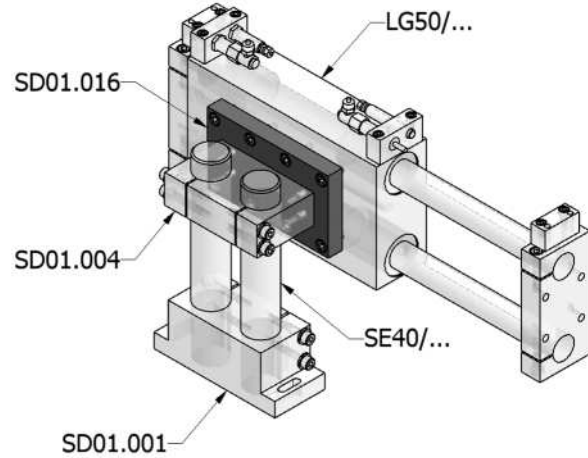
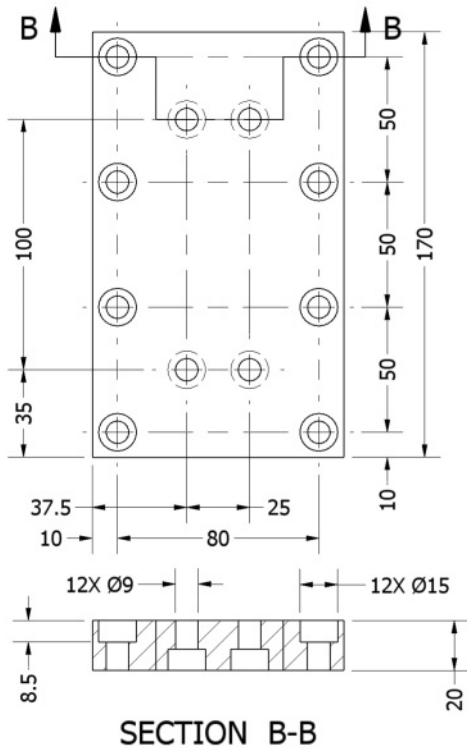

# Stands and Mounting Brackets – Examples of Application

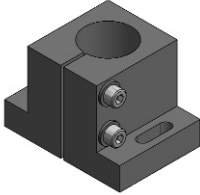
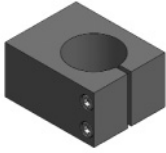
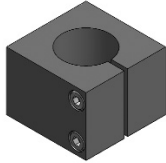
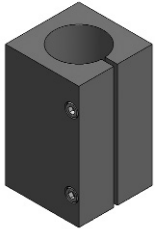
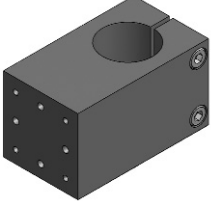
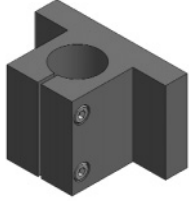
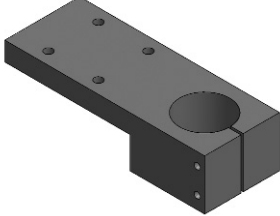
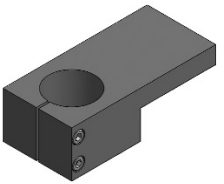

# Stands & Modular Mounting Brackets & Adapter Plates

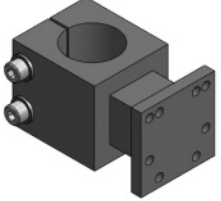
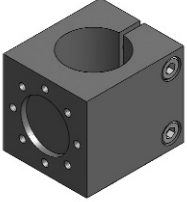
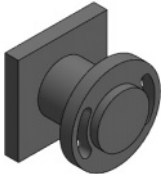
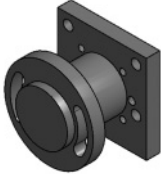
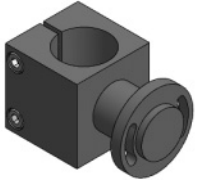
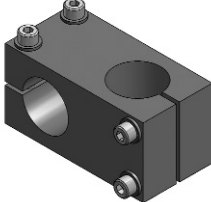
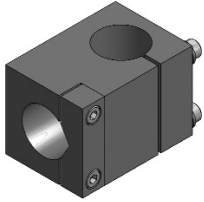
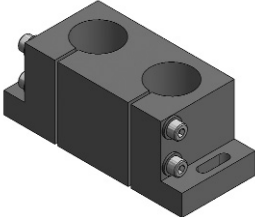
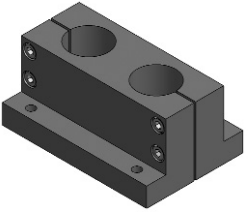
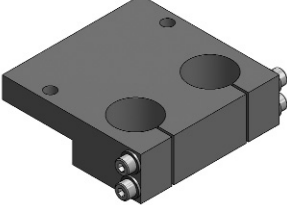
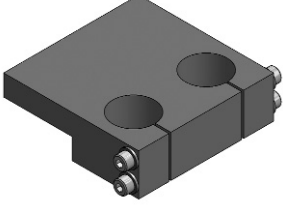
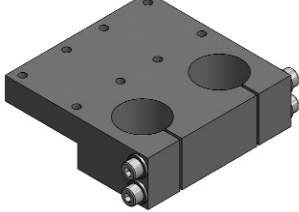
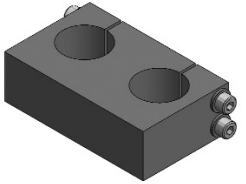
<p><b>SE01.001</b></p> 	<p><b>SE01.017</b></p> 	<p><b>SE01.068</b></p> 	<p><b>SE01.007</b></p> 
<p><b>SE01.060</b></p> 	<p><b>SE03.001</b></p> 	<p><b>SE01.027</b></p> 	<p><b>SE01.008</b></p> 
<p><b>SE01.014</b></p> 	<p><b>SE01.023</b></p> 	<p><b>SE01.024</b></p> 	<p><b>SE01.010</b></p> 
<p><b>SE01.018</b></p> 	<p><b>SE01.055</b></p> 	<p><b>SE01.054</b></p> 	<p><b>SE01.019</b></p> 
<p><b>SE01.003</b></p> 	<p><b>SE01.030</b></p> 	<p><b>SD01.001</b></p> 	<p><b>SD03.001</b></p> 
<p><b>SD01.005</b></p> 	<p><b>SD01.003</b></p> 	<p><b>SD01.002</b></p> 	<p><b>SD01.006</b></p> 

# Stands & Modular Mounting Brackets & Adapter Plates

SD01.004

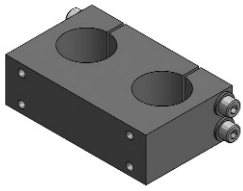

SD01.013

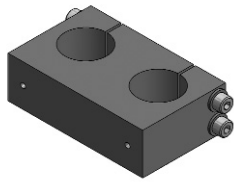

SD01.032

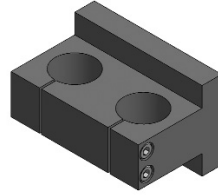

SD01.008

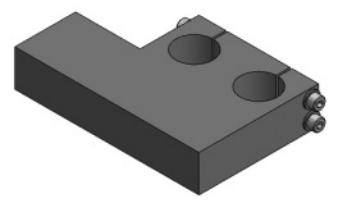

SD01.009

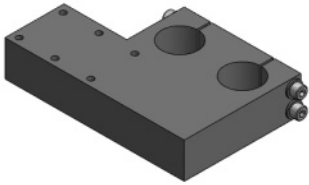

SD01.025

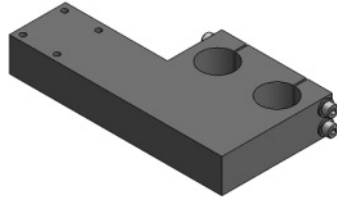

SD01.200

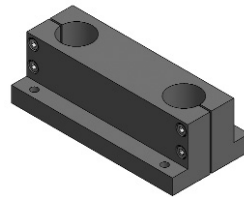

SD01.201

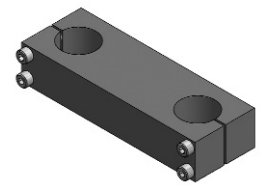

SD01.202

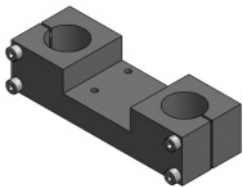

SD01.190

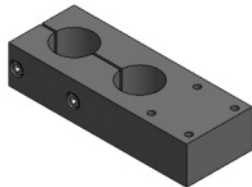

SD01.011

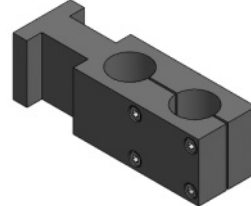

SD01.012

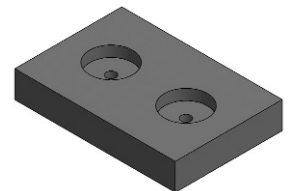

SD01.016

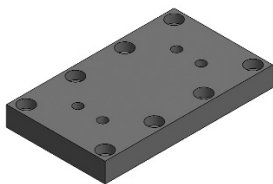

SE03.300

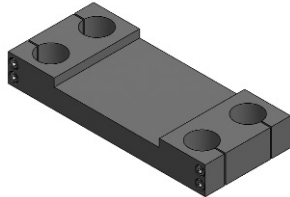

SD50.001

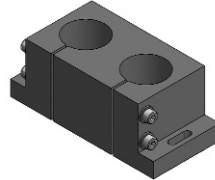

SD50.140

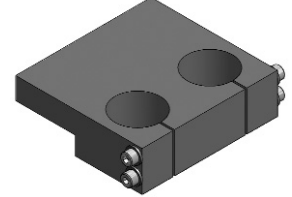

SE40.300



SE40.M06

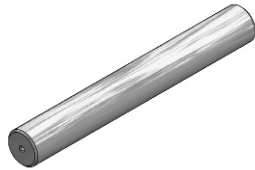

SE50.300



N003.008

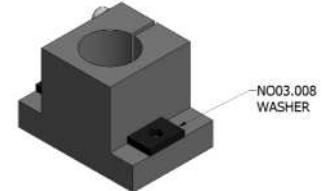

# Stands and Modular Mounting Brackets

## Stand Base

Order Number	Dimension
SE 01.001	100 X 70 mm

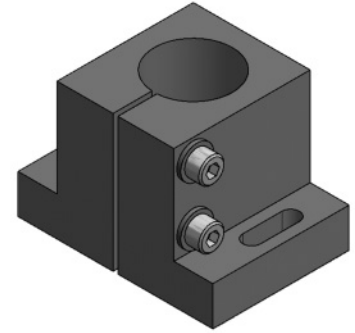
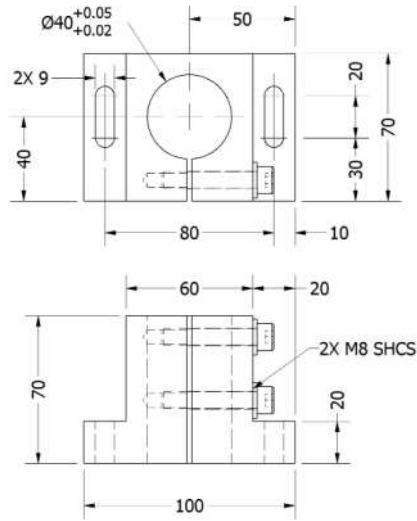

## Mounting Bracket

Order Number	Dimension
SE 01.017	75 x 60 mm

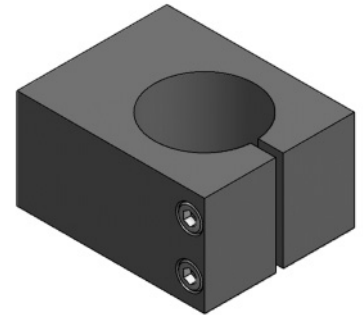
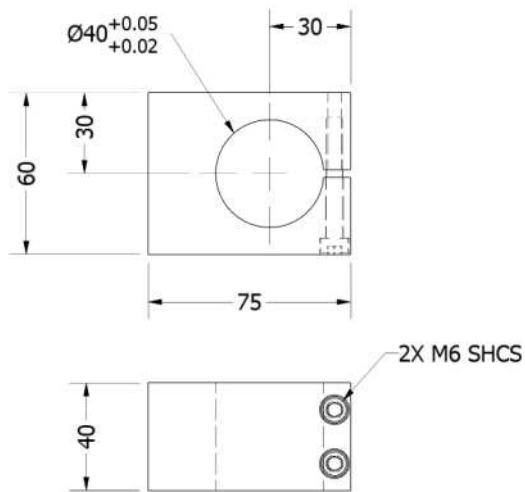

## Mounting Block

Order Number	Dimension
SE 01.068	68 x 68 mm
SE 01.088	88 x 68 mm

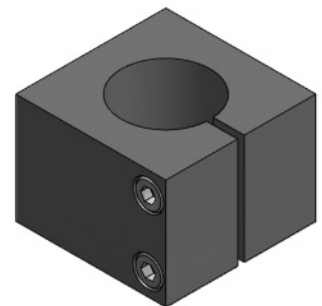
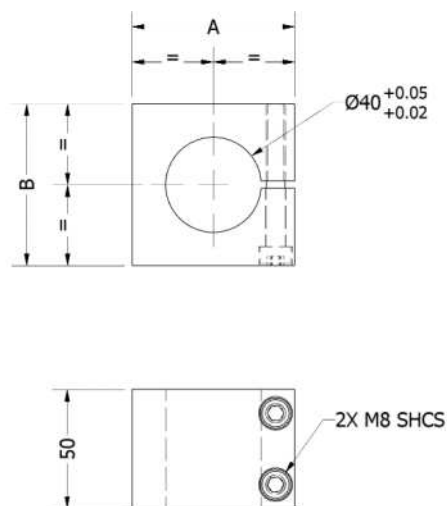

# Stands and Modular Mounting Brackets

## Mounting Bracket

Order Number	Dimension
SE 01.007	60 x 60 mm

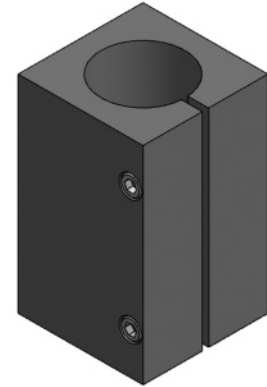
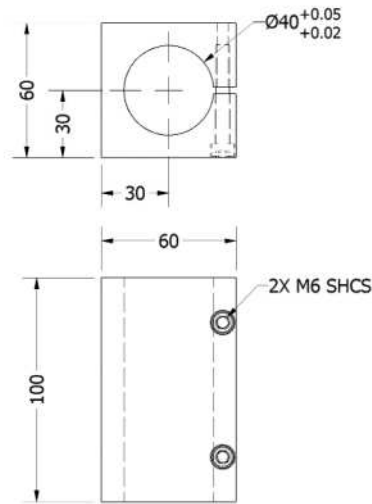

## Mounting Bracket

Order Number	Dimension
SE 01.060	105 x 60 mm

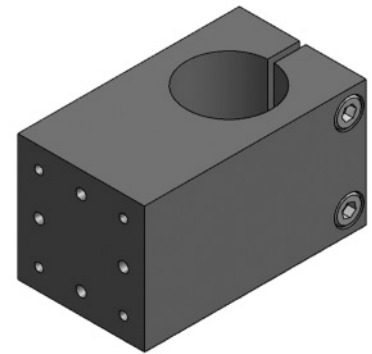
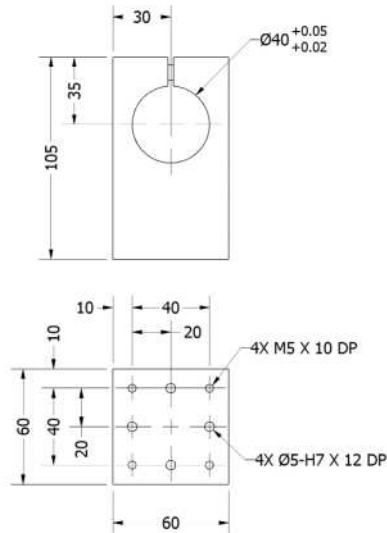

## Mounting Bracket

Order Number	Dimension A
SE 03.001	100 mm
SE 03.002	120 mm
SE 03.003	140 mm

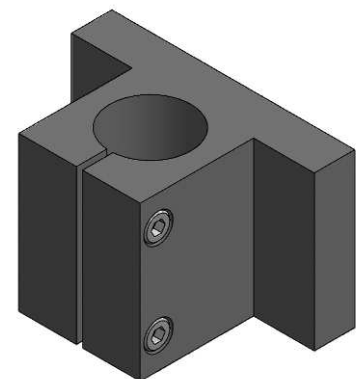
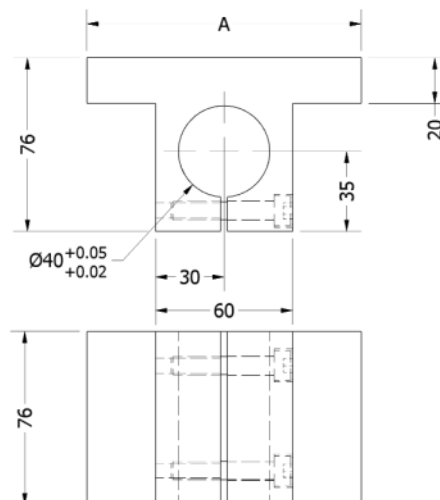

# Stands and Modular Mounting Brackets

## Mounting Bracket for ML 26

Order Number	Dimension
SE 01.027	160 x 60 mm

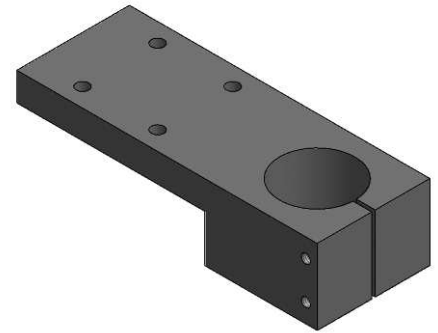
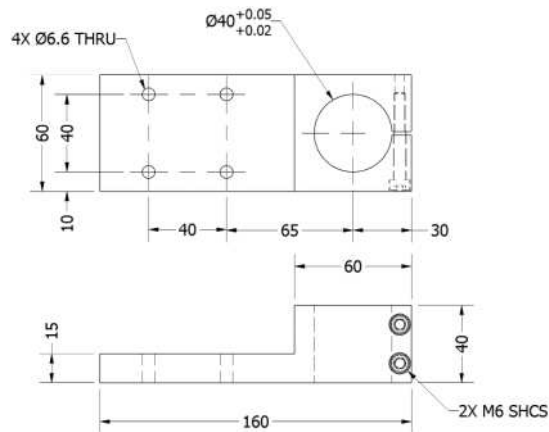

## Mounting Bracket

Order Number	Dimension
SE 01.008	126 x 60 mm

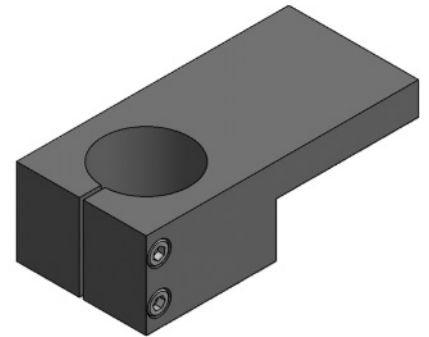
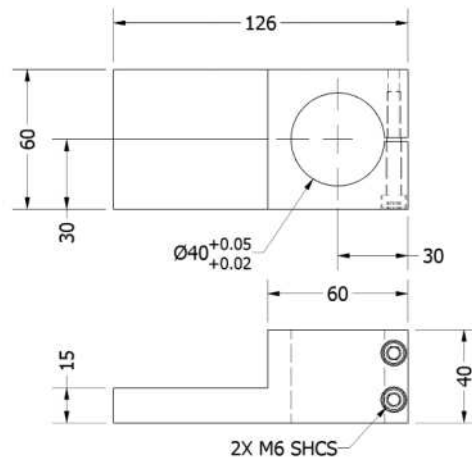

## Mounting Plate for KOB50

Order Number	Dimension
SE 01.014	160 x 50 mm

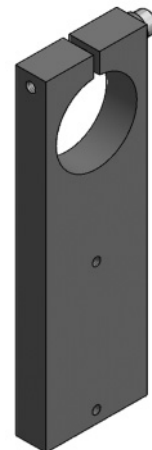
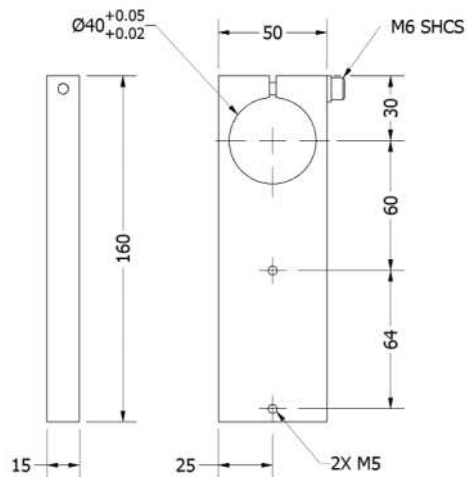



# Stands and Modular Mounting Brackets

## Mounting Plate

Order Number	Dimension A
SE 01.023	100 mm
SE 01.022	160 mm
SE 01.021	200 mm
SE 01.020	250 mm
SE 01.012	278 mm

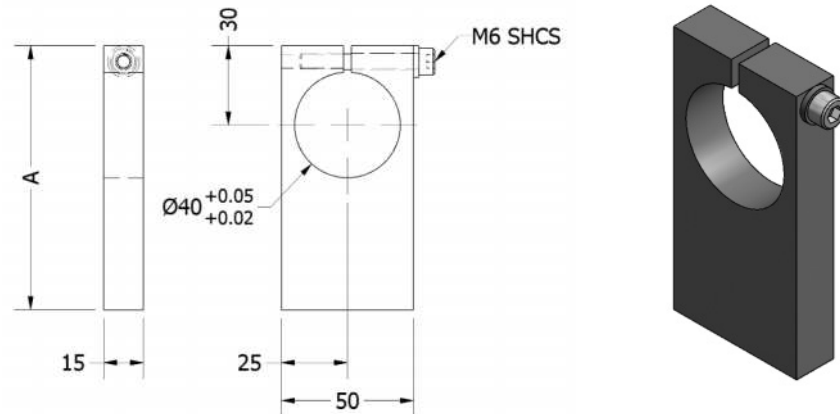

## Mounting Plate

Order Number	Dimension A
SE 01.024	100 mm
SE 01.025	160 mm
SE 01.026	200 mm

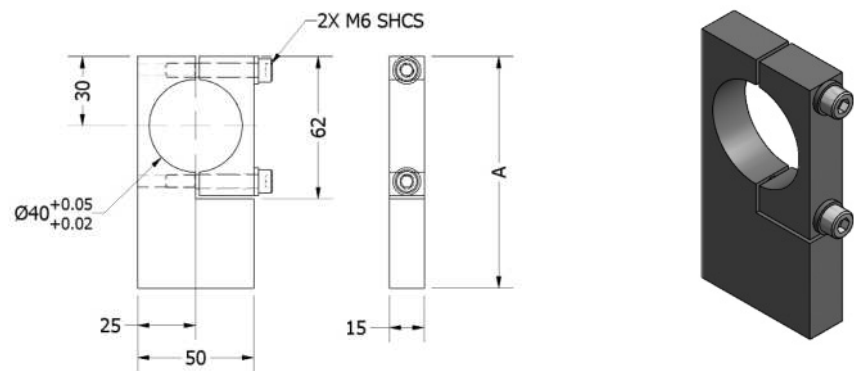

## Mounting Bracket for VE

Order Number	Dimension A
SE 01.010	105 mm
SE 01.016	180 mm

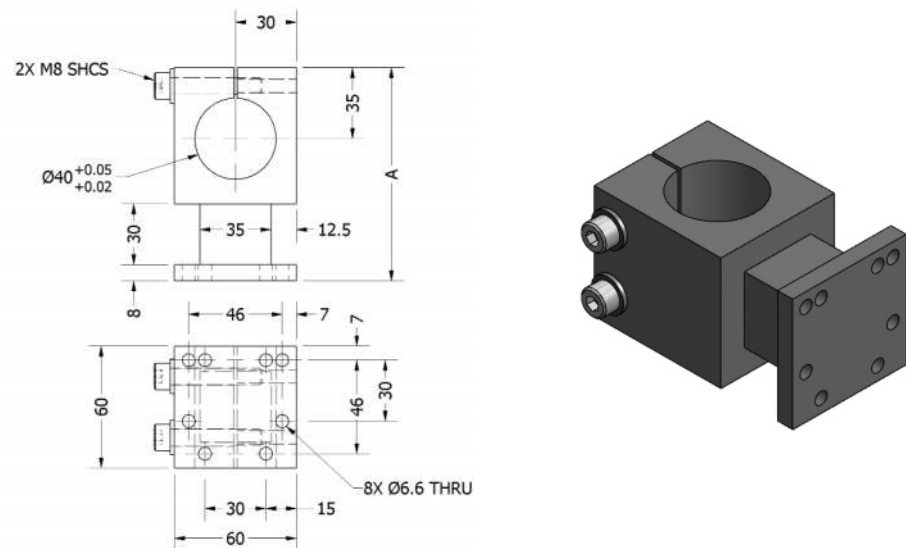

# Stands and Modular Mounting Brackets

## Support Block

Order Number	Dimension
SE 01.018	70 X 60 mm

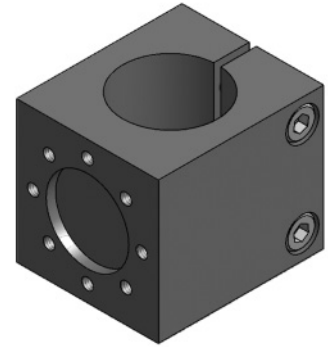
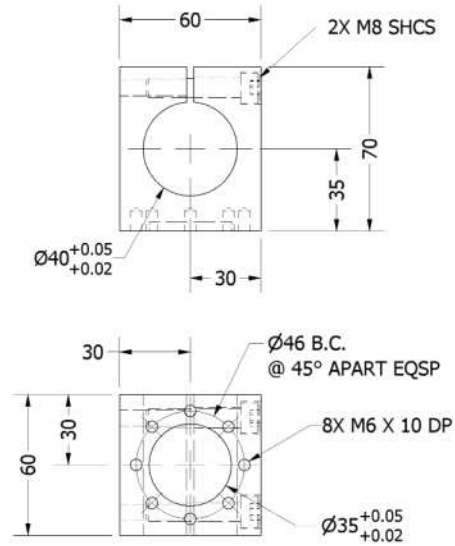

## Mounting Bracket

Order Number	Dimension
SE 01.055	50 X 60 mm

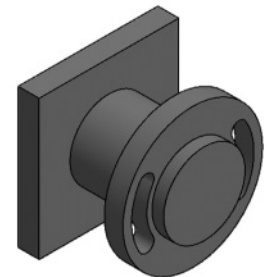
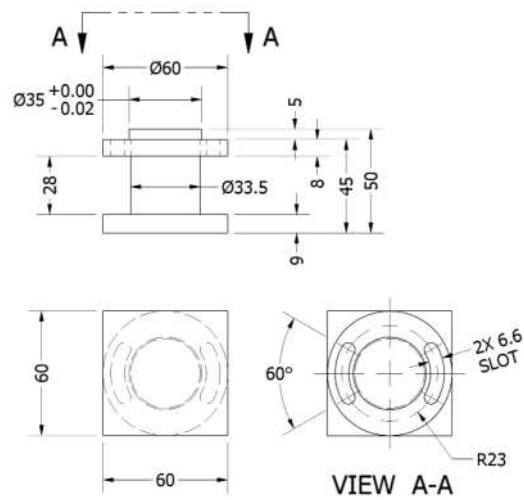

## Mounting Bracket

Order Number	Dimension
SE 01.054	50 X 60 mm

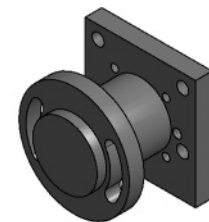
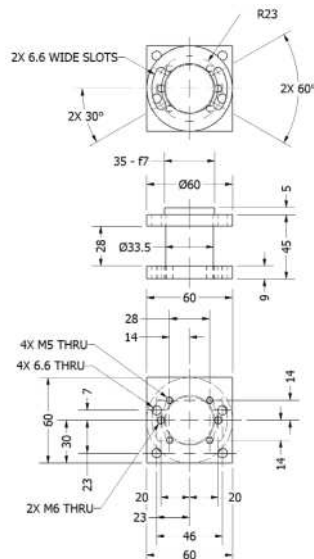

# Stands and Modular Mounting Brackets

## Mounting Bracket

Order Number	Dimension
SE 01.019	100 x 60 mm

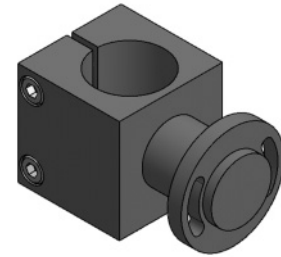
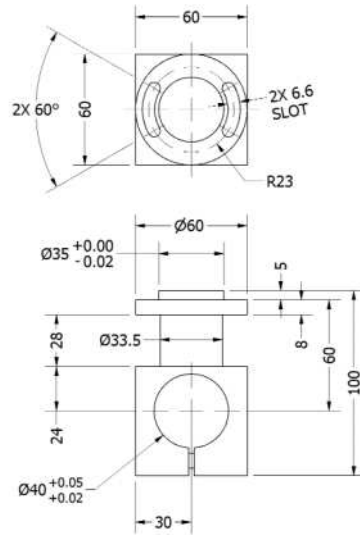

## Mounting Bracket

Order Number	Dimension
SE 01.003	120 X 60 mm

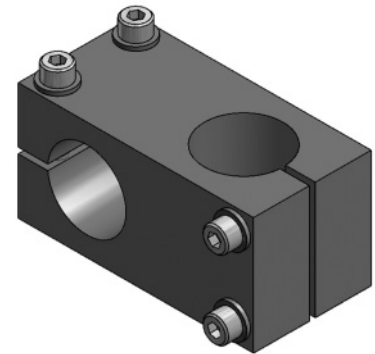
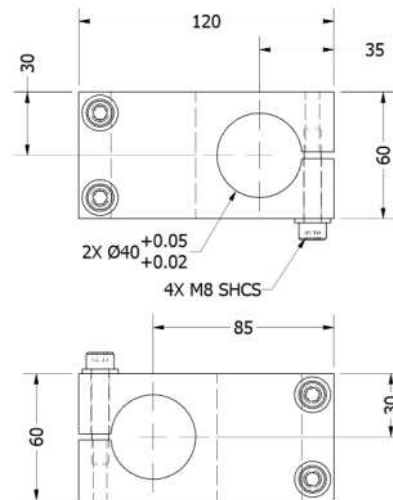

## Mounting Bracket

Order Number	Dimension
SE 01.030	160 X 70 mm

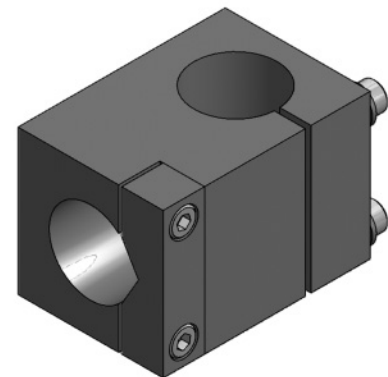
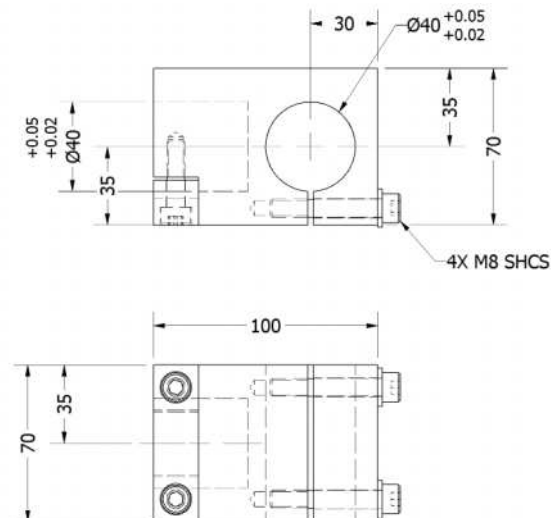

# Stands and Modular Mounting Brackets

## Stand Base

Order Number	Dimension
SD 01.001	170 x 70 mm

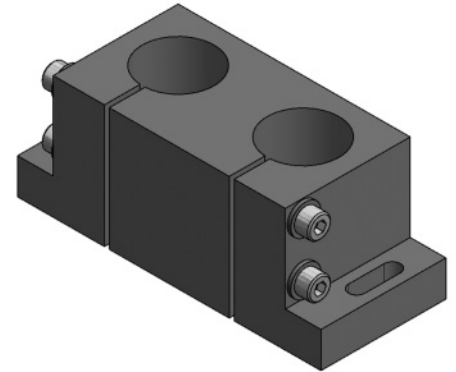
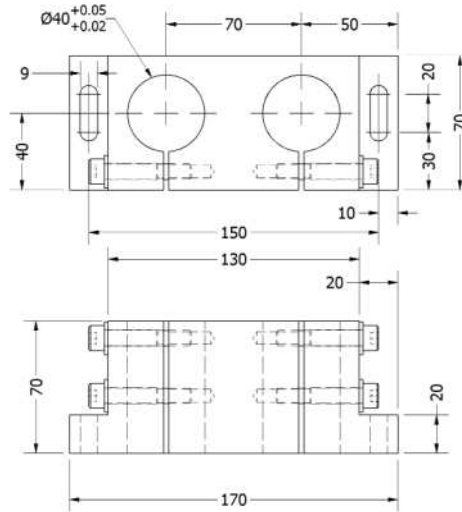

## Stand Base

Order Number	Dimension
SD 03.001	140 X 88 mm

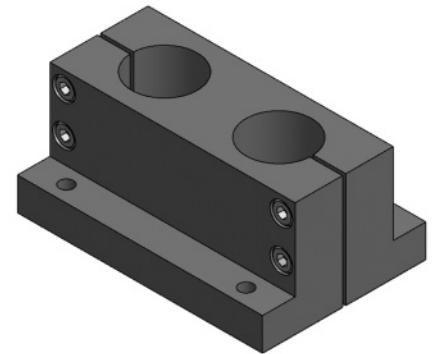
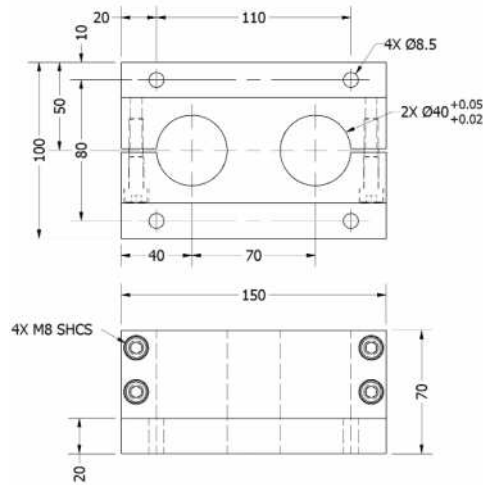

## Mounting Plate for Angle Loader

Order Number	Dimension
SD 01.005	130 x 130 mm

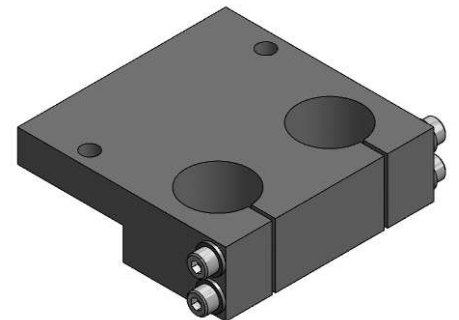
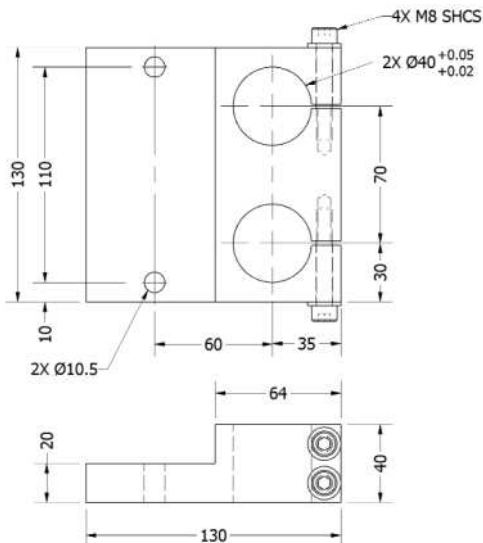

# Stands and Modular Mounting Brackets

## Mounting Plate

Order Number	Dimension A
SD 01.003	130 mm
SD 01.010	160 mm
SD 01.007	200 mm

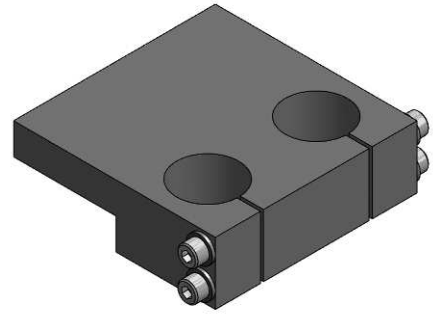
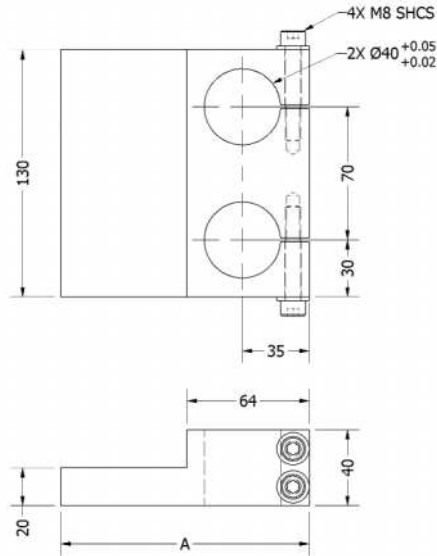

## Mounting Plate for LH

Order Number	Dimension
SD 01.002	130 x 130 mm

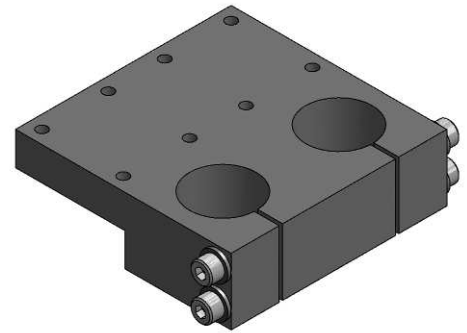
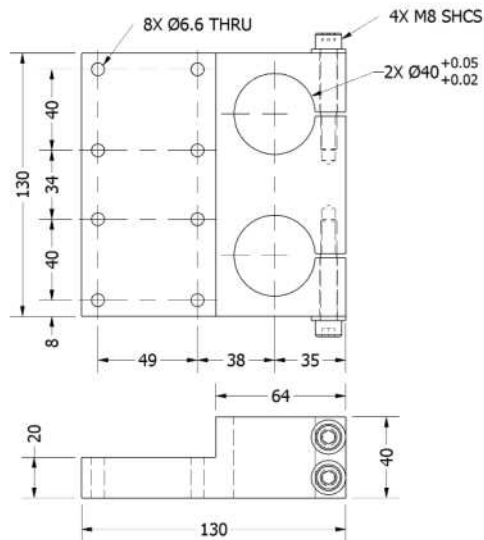

## Mounting Bracket

Order Number	Dimension A
SD 01.006	80 mm
SD 01.060	100 mm
SD 01.066	120 mm

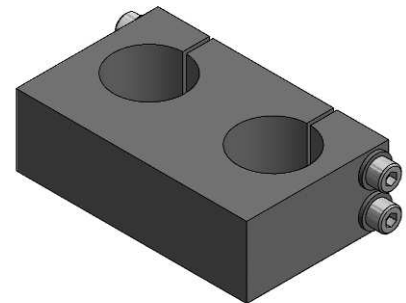
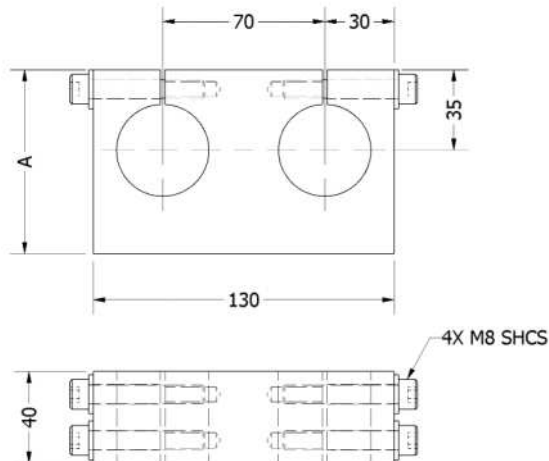

# Stands and Modular Mounting Brackets

## Mounting Block

Order Number	Dimension
SD 01.004	130 X 80 mm

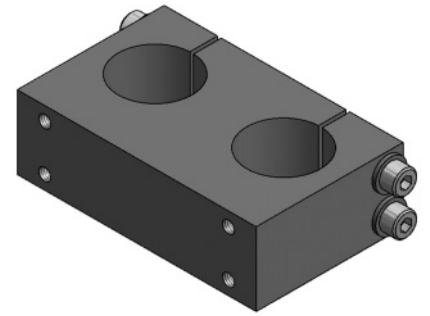
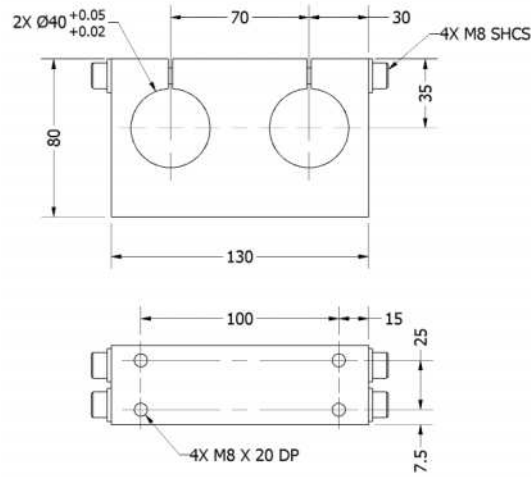

## Mounting Bracket

Order Number	Dimension				
	A	B	C	D	E
SD 01.013					
NT 61	130	30	14.5	101	M6/18
SD 01.014					
NT 120	150	40	8	134	M8/20

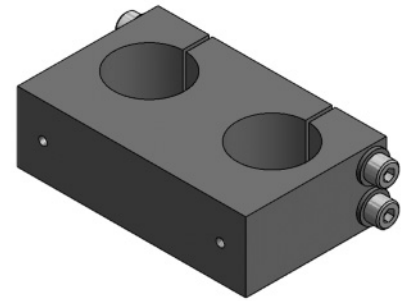
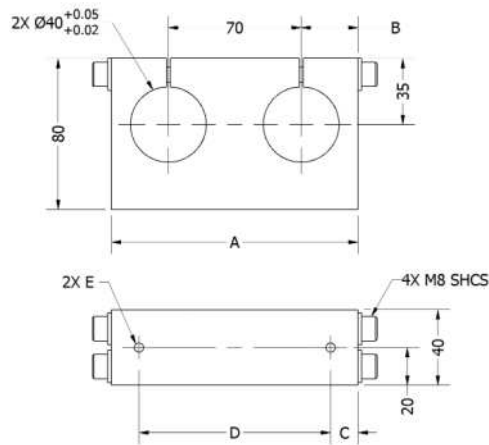

## Mounting Block

Order Number	Dimension
SD 01.032	130 x 85 mm

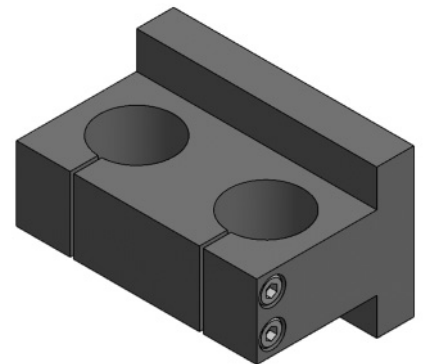
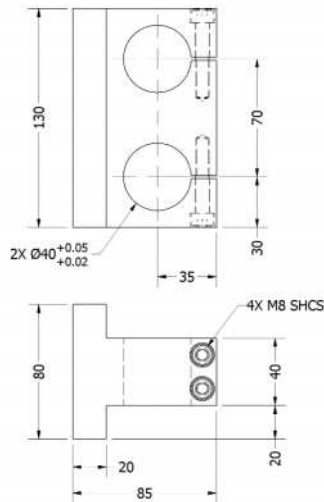

# Stands and Modular Mounting Brackets

## Mounting Plate

Order Number	Dimension
SD 01.008	130 x 200 mm

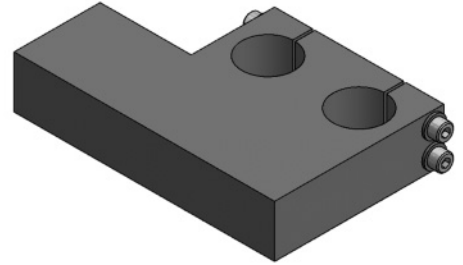
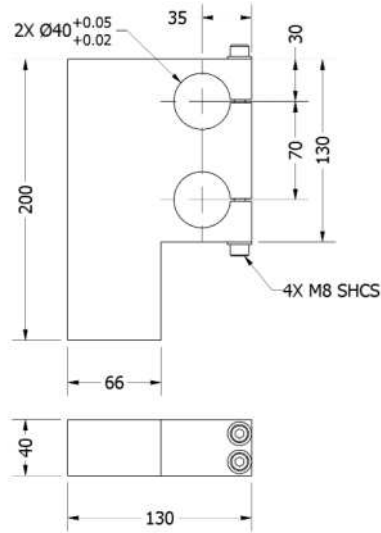

## Mounting Plate / LH

Order Number	Dimension
SD 01.009	200 mm

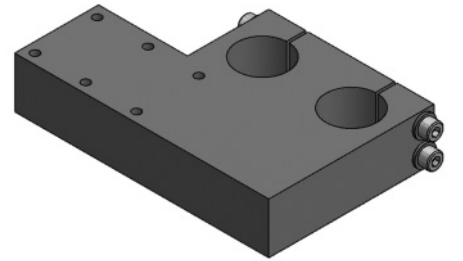
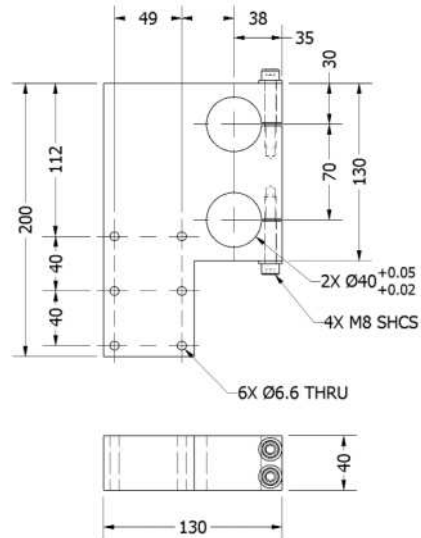

## Mounting Plate / LH

Order Number	Dimension
SD 01.025	130 X 250

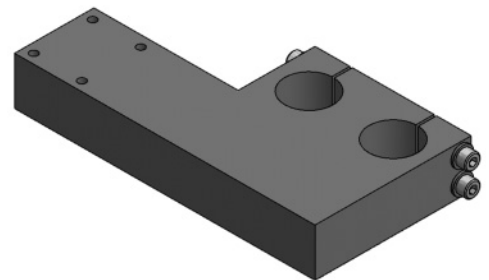
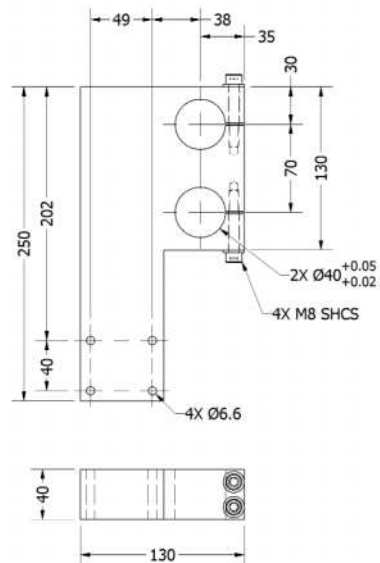

# Stands and Modular Mounting Brackets

## Stand Base

Order Number	Dimension
SD 01.200	204 X 88 mm

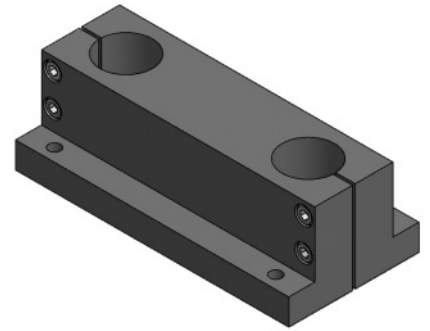
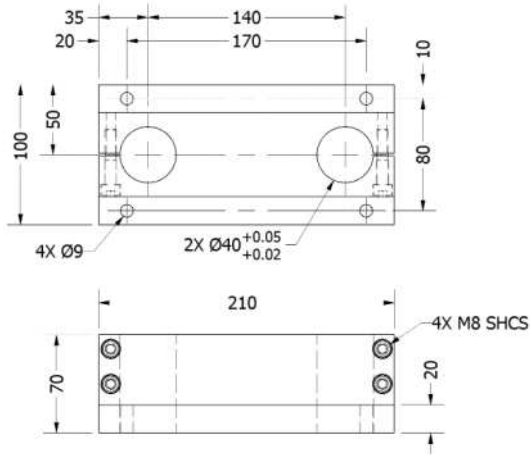

## Mounting Bracket

Order Number	Dimension
SD 01.201	204 X 70 mm

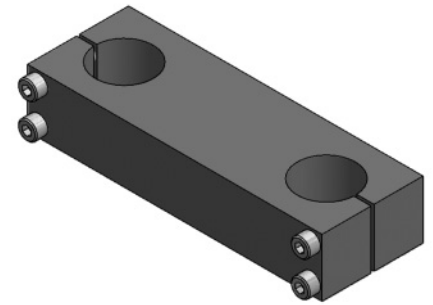
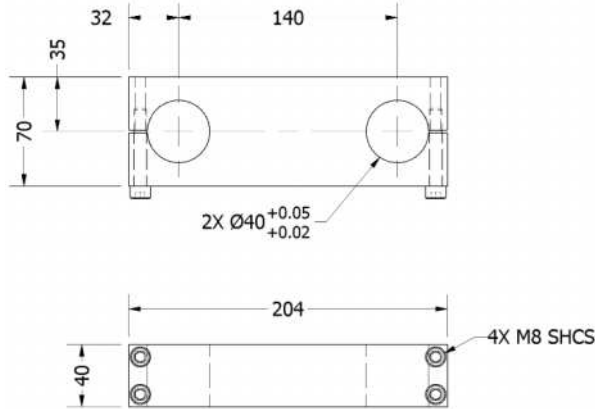

## Mounting Block / LH

Order Number	Dimension
SD 01.202	204 X 70 mm

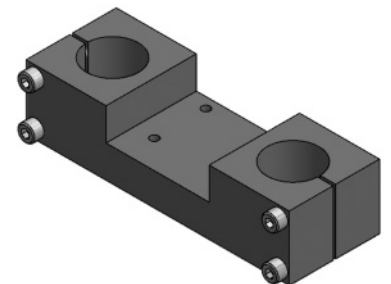
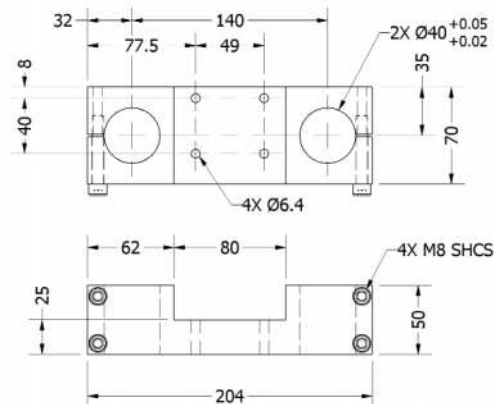



# Stands and Modular Mounting Brackets

## Mounting Block / LH

Order Number	Dimension A
SD 01.190	190 mm
SD 01.220	220 mm
SD 01.250	250 mm

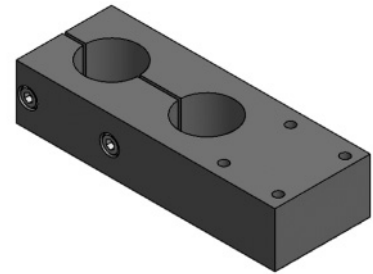
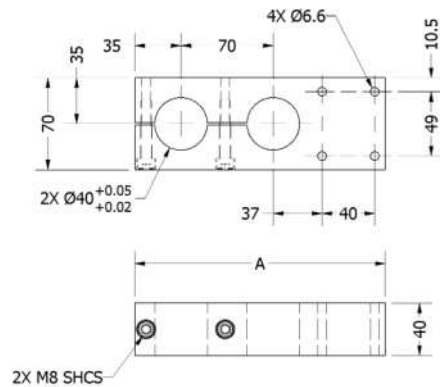

## Mounting Block

Order Number	Dimension
SD 01.011	200 X 62 mm

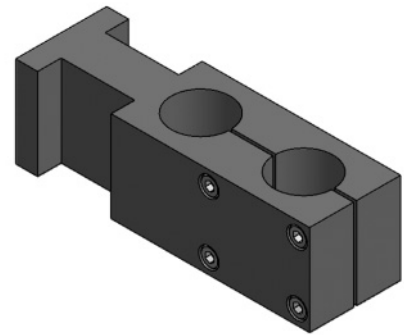
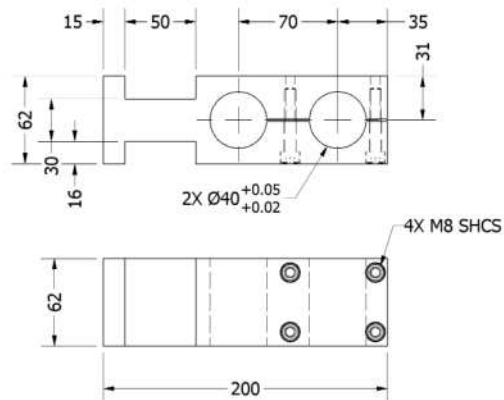

## Mounting Plate

Order Number	Dimension
SD 01.012	150 x 100 mm

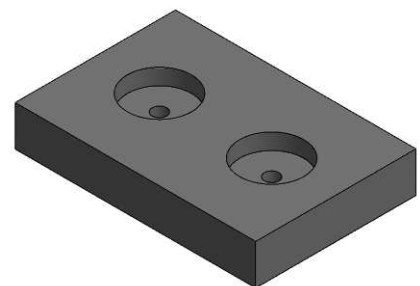
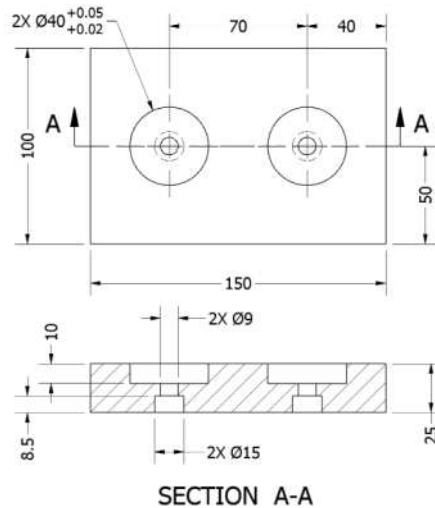

# Stands and Modular Mounting Brackets

## Mounting Plate / LG

Order Number	Dimension
SD 01.016	170 x 100 mm

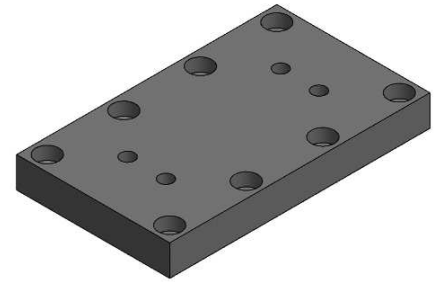
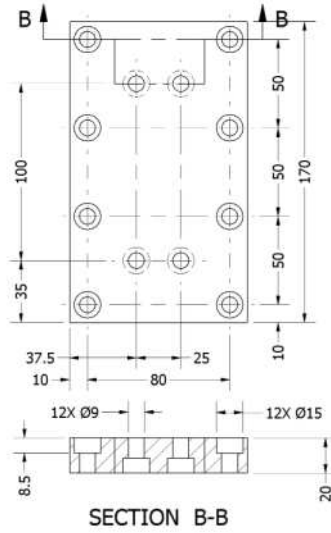

## Mounting Plate

Order Number	Dimension	
	A	B
SE 03.300	300 mm	160 mm
SE 03.400	400 mm	260 mm
SE 03.500	500 mm	360 mm

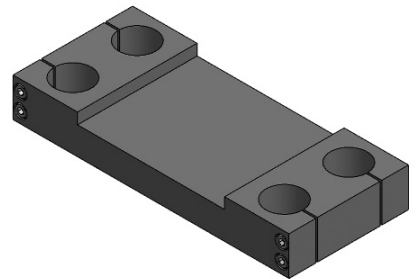
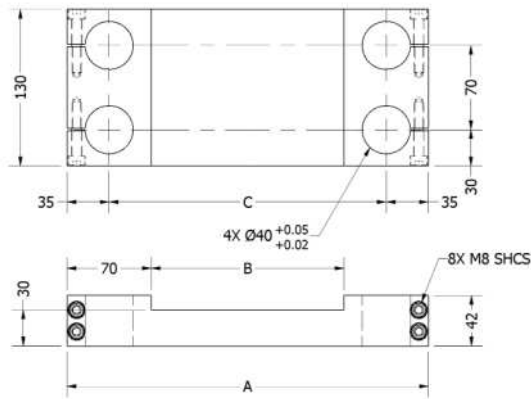

## Mounting Plate

Order Number	Dimension
SD 50.001	190 x 88 mm

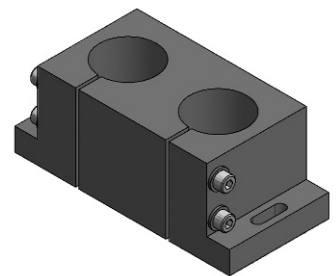
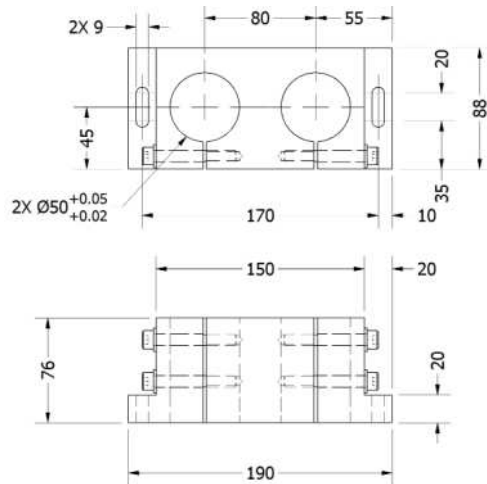

# Stands and Modular Mounting Brackets

## Mounting Plate

Order Number	Dimension A
SD 50.140	140 mm
SD 50.180	180 mm
SD 50.220	220 mm
SD 50.260	260 mm

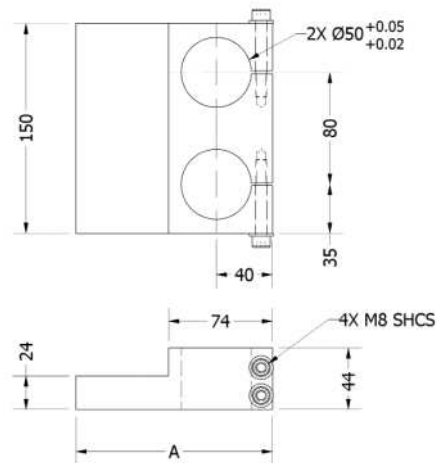

## Pillar

Order Number	
SE 40 x .....	any custom length

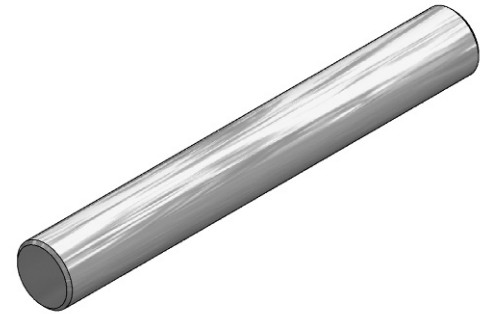
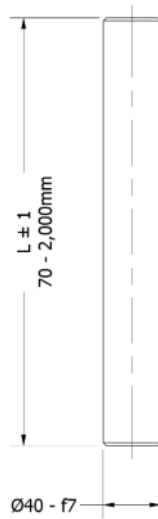

## M6, M8, M12

Order Number	
SE 40M06-	
SE 40M08-	
SE 40M12-	

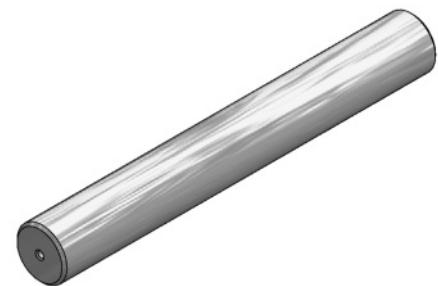
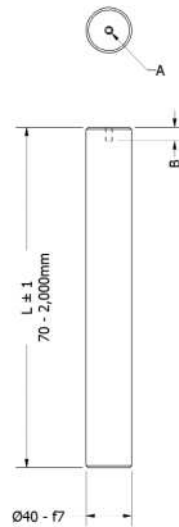

# Stands and Modular Mounting Brackets

## Pillar

Order Number	L
SE 50 x 300	300 mm
SE 50 x ...	Custom

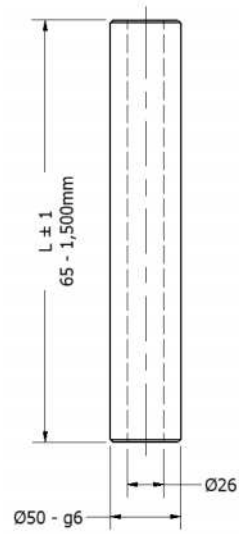

## Washer

Order Number
NO 03.008

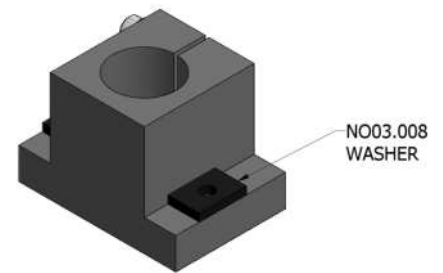
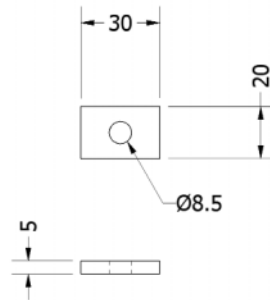

## HANDLING SYSTEMS AND SPRING FEEDER

SECTION 7

**meto-fer®**  
**automation**

Your complete source for industrial automation and electronics

**mf automation, inc.**

[www.meto-fer.com](http://www.meto-fer.com)

1-888-638-6337

# Automated Tray Changer

## (Transfer and tray storage unit AP)

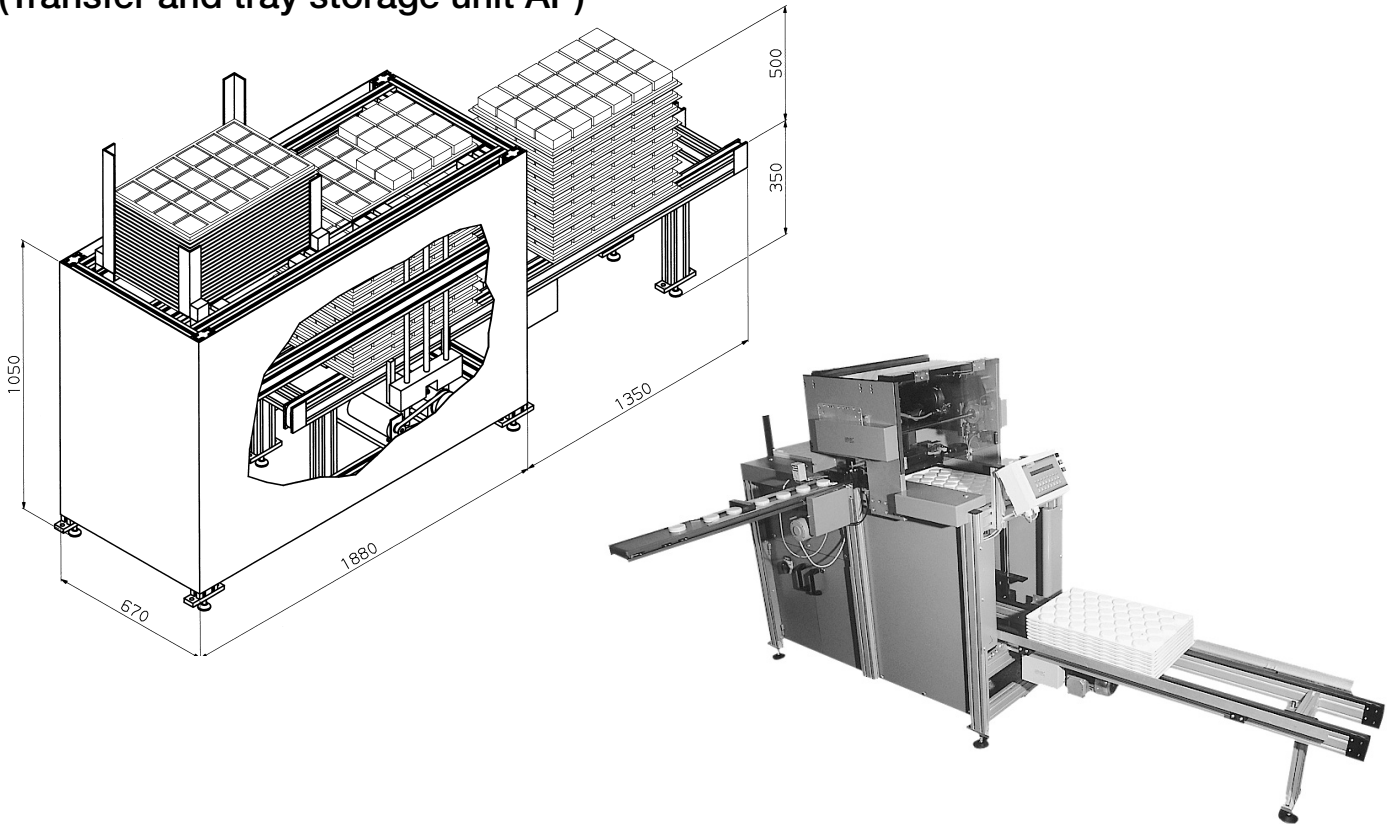

### Description

The transfer and tray storage unit is used for automatic loading/unloading of trays.

The tray to be loaded is singled out on the tray stack downward and is brought into the loading position by the electrical drive unit.

The advance of the trays is programmable to your choice and programs can be stored in the controller unit.

The loaded trays are stacked onto each other and lowered within the unit downward to the transfer unit.

This transfer unit moves the whole stack of trays out of the system.

This unit is designed to allow the procedure described above also to be carried out in reverse order.

This unit is equipped with an individual controller, which also allows the controlling of the handling unit.

In addition, this transfer and tray storage unit can be equipped with any automation component of modular design within our range of products. The parts can then be loaded/unloaded individually or serially.

Typical applications are: difficult parts to sort out, or parts which must not be scratched, e.g. cosmetic products.

### Technical Data:

- Tray size 400 x 600 mm (other dimensions are also possible)
- Tray changing time approx.. 5 seconds
- Stack height 400 mm
- Total weight of tray stack approx.. 30 kgs

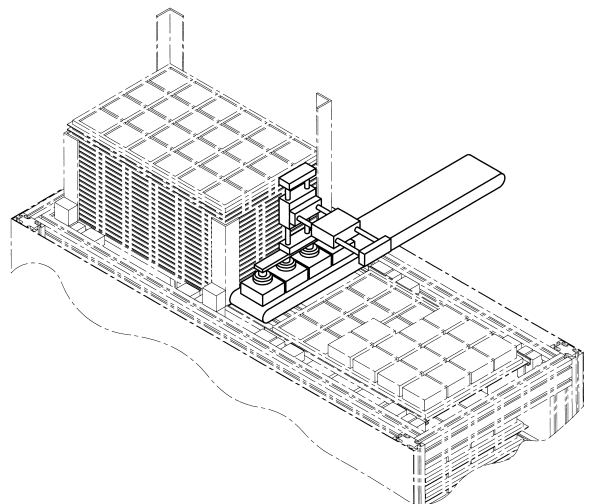
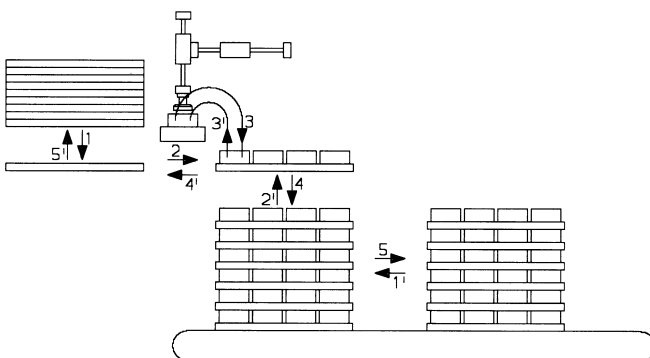

# Shaft Hopper WM-01

Order No. WM-01 - . . .

O = No sensors  
 N = Sensors NPN (M8x1)  
 P = Sensors PNP (M8x1)

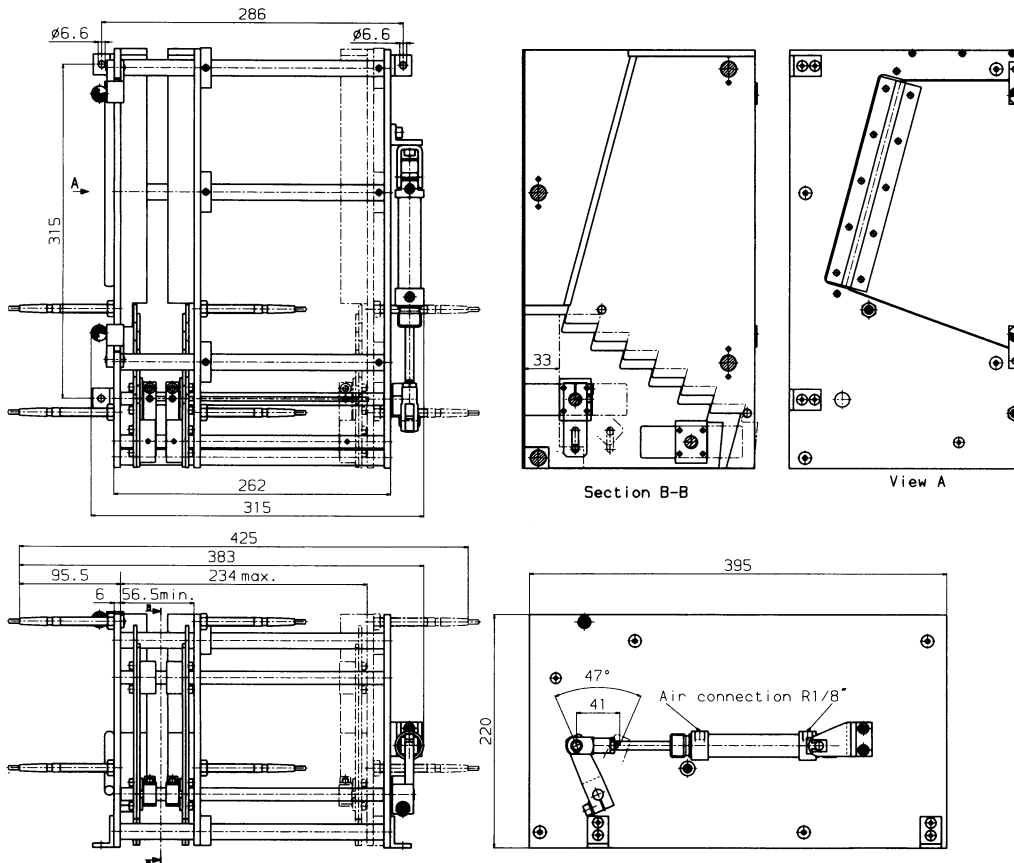
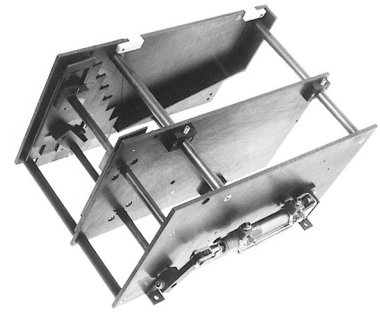

The shaft hopper separates and prepositions shafts with a diameter from 6 to 26mm. The length of the work pieces can range from 56 to 254mm. (2,2" to 10")

Parts must have the same length and the same orientation. A simple shifting of the internal partitioning adjusts to a different work piece length.

A stepped mechanic that moves up and down separates the shafts. It is driven by a pneumatic cylinder. The uppermost step can be used as an unloading position for the parts; but it is also possible to convey the shafts to another suited installation (for example transport device) without using an unloading device.

The shaft hopper is equipped with a level measuring device and a control for the unloading position. A flap at the side allows to magazine even short shafts without problems.

Weight of the hopper approx. 44 lb (20 kg)

# Spring feeder FG

For disentangling and feeding of cylindrical springs with air.

**NOTE:** Each spring must be checked out individually for feed suitability. About 0.3 liter (.33 quarts) of regular production springs are needed for evaluation.

## SPRING:

- Outer spring diameter 2-8mm (0.0788" - 0,3152")
- Length up to 30mm (1,182")
- Special version up to  $\varnothing$  18mm (0.708")
- Length 5-45mm (0.196" - 1,771")

## Technical data:

- Simple and quick refill of springs
- *Hopper for additional bulk quantity of springs (see back page)*
- 1-6 outputs (dependant on feed rate, dimension and form of spring)
- Rate per output: up to 100 PCS/ min.
- Air connection: R 1/8"
- Operating medium: compressed air / oil free
- Operating pressure: 2-6 bar (30-90 psi)
- Air consumption: per operating cycle at 72.5 psi (5 bar): .883 scf (25 NL)
- Volume: 0,5 litre (.55 quarts)
- Weight: 30 kg (66.2 lb)

The unit is supplied with a matching nozzle, tube mount and 2-meter tube.

## CONTROL UNIT:

The control unit is equipped with an automatic on / off (FG will switch on only as required)  
Voltage: 24 volts DC

## Order No.

- FG - -
- A = valves, regulator, compl. with tubing, without ring initiator
  - B = valves, regulator, compl. with tubing with control unit, with ring initiator (1 pc. per output)
- Number of outputs 1-6

Ring initiator version PNP

Order No. IR\_\_PSK-IBS

Ring Diameter (I.D.)

## Single escapement EF for springs and cylindrical pins

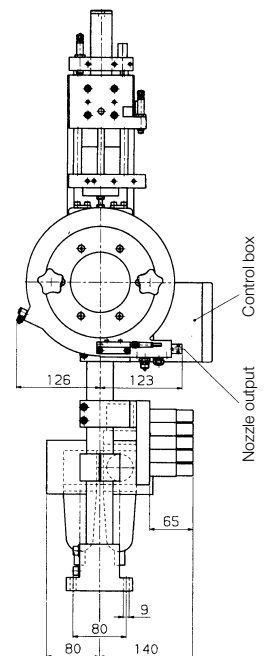
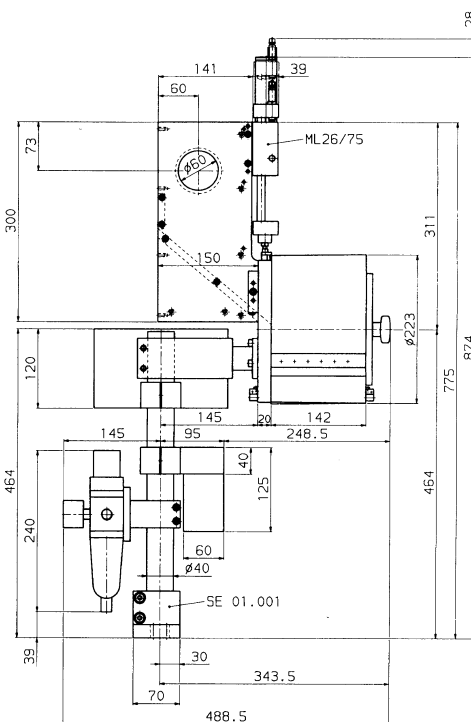
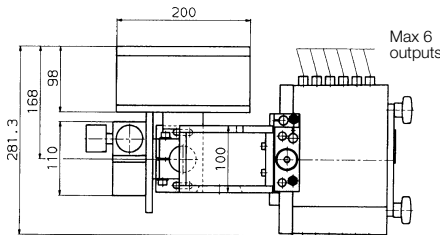
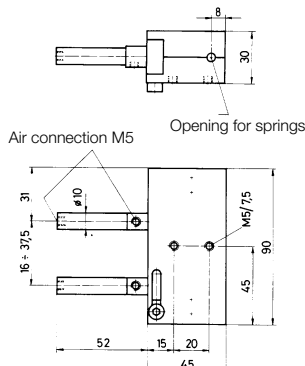

The single escapement must be matched to the spring diameter.

## Technical data:

- Outer spring diameter 2-8mm (0,078" - 0,315")
- Spring length 5 to 40mm (.196"-1,574")
- Call us for details about your custom size
- Air connection M5 Operating medium: compressed air/ oil free
- Operating pressure: 2-6 bar (30-90 psi)
- Air Consumption: per operating cycle at 72.5 psi: 0.014 NL
- Weight: 0,85 kg (1.87lb)

Order No. EF 01.000



# Hopper FG

Available in two models, the Hopper holds a bulk quantity of springs and easily facilitates automatic refilling of the Spring Feeder.

## MODEL – S

This model does not have a quick empty feature.

Order No.: FG-Hopper-S

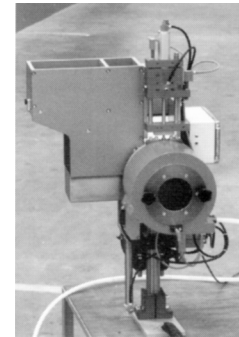
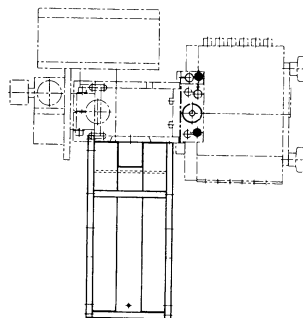
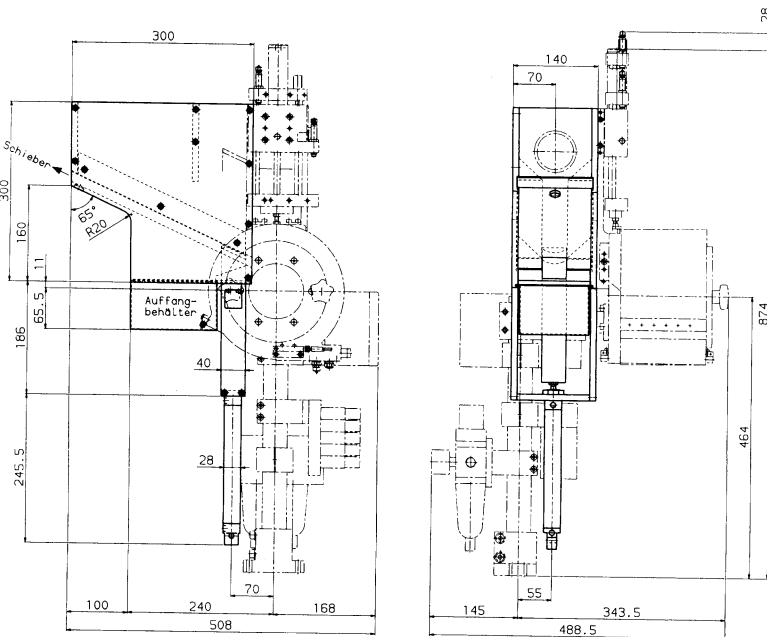
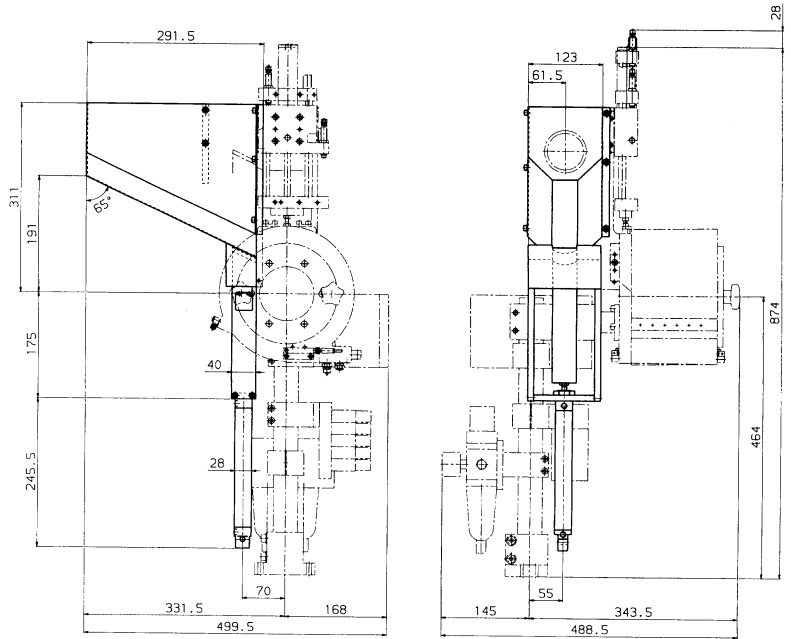

## MODEL – L

FG-Hopper-L is recommended when your application requires feeding various types of springs with the same spring feeder. Model – L also provides a Quick-Empty feature, by simply pulling the drawer.

Order No.: FG-Hopper-L

# NC-Winding Machine FW-01

for spiral torque springs

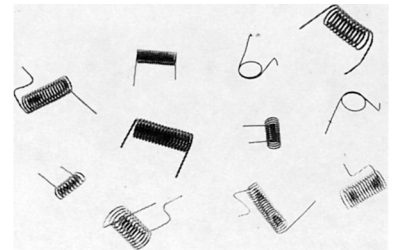
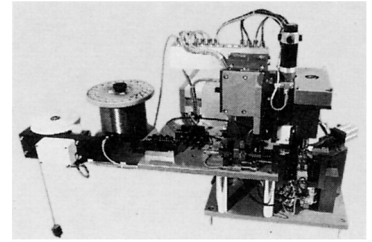
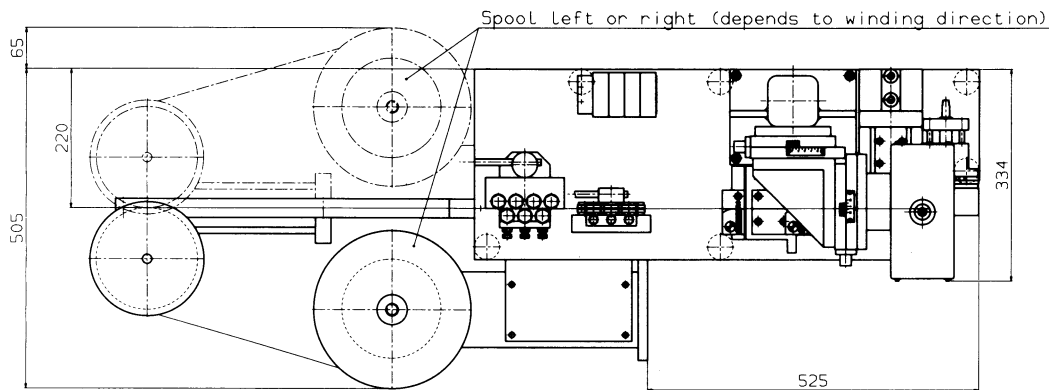

Example of a stripped coil

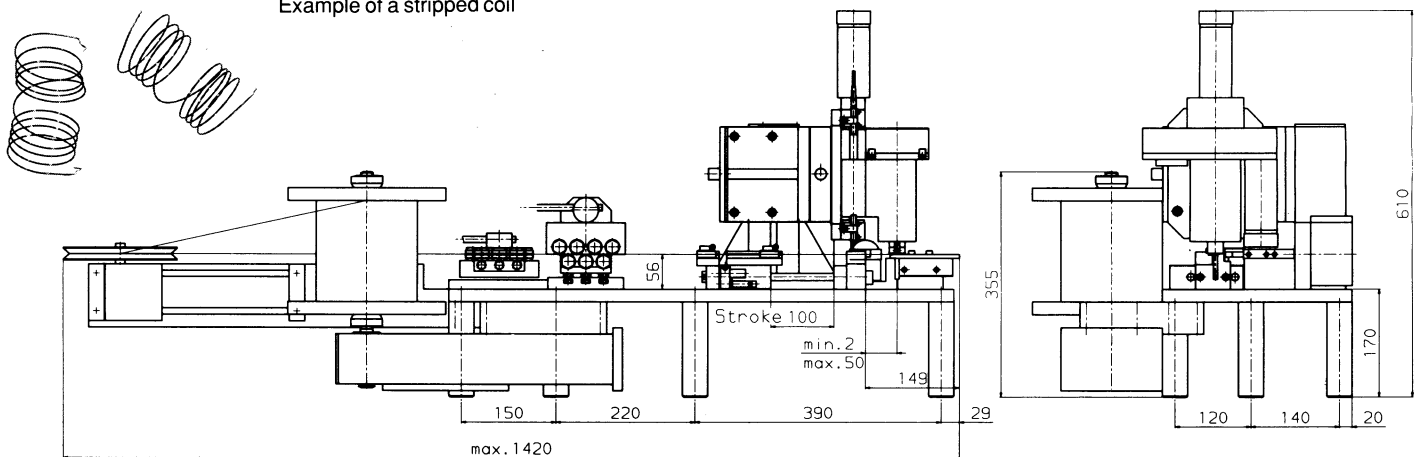

The Meto-Fer NC-winding machine produces spiral springs with legs, for use in torquing applications, and coiled resistance wires directly from a spool. The machine can be integrated directly into an assembly installation, or used as a stand-alone machine.

A traversing spindle is used to wind the springs. Two programmable DC motor driven CNC-axes drive the winding process. All other movements are controlled pneumatically. The CNC control unit is an integral part of the spring winding machine.

Tooling adjusts to accommodate different coil lengths. Simple tooling changes accommodate different coil diameters and leg lengths. If necessary, additional tools can be used to bend and form the legs of the springs. Please note that this standard machine is optimized to produce spiral springs with legs, and is not intended to be used to produce compression springs or tension springs.

<b>Technical Data:</b>	Smallest wire diameter	approx.	0.2	mm
	Largest wire diameter	approx.	1.5	mm (depends on torque)
	Smallest coil diameter (centerline to centerline)	approx.	2	mm
	Largest coil diameter (centerline to centerline)	approx.	30	mm (depends on torque)
	Minimum length of legs		1/2	of outside diameter
	Maximum length of legs		50	mm
	Maximum total length of both legs		100	mm (legs 2 x 50 mm)
	Maximum length of coil		42	mm
	Nominal RPM of winding spindle		300	RPM
	Nominal torque		33.6	lb.in (3.8 Nm)
	Fast vertical motion of winding spindle		49.2	ft/min (15 m/min )
	Force of cutting tool		562	lb at 72.5 psi (2500 N at 5 bar)
	Pneumatic operating pressure		58 - 116	psi (4 - 8 bar)
	Electrical power requirements	approx.	1.341	hp (1 kW)
	Overall dimensions (Length x Width x Height)		1420 x 505 x 610	mm
	Weight	approx.	200	lb (90 kg)

# Pick and Place Load Station

(with Vibratory Bowl Feeder)

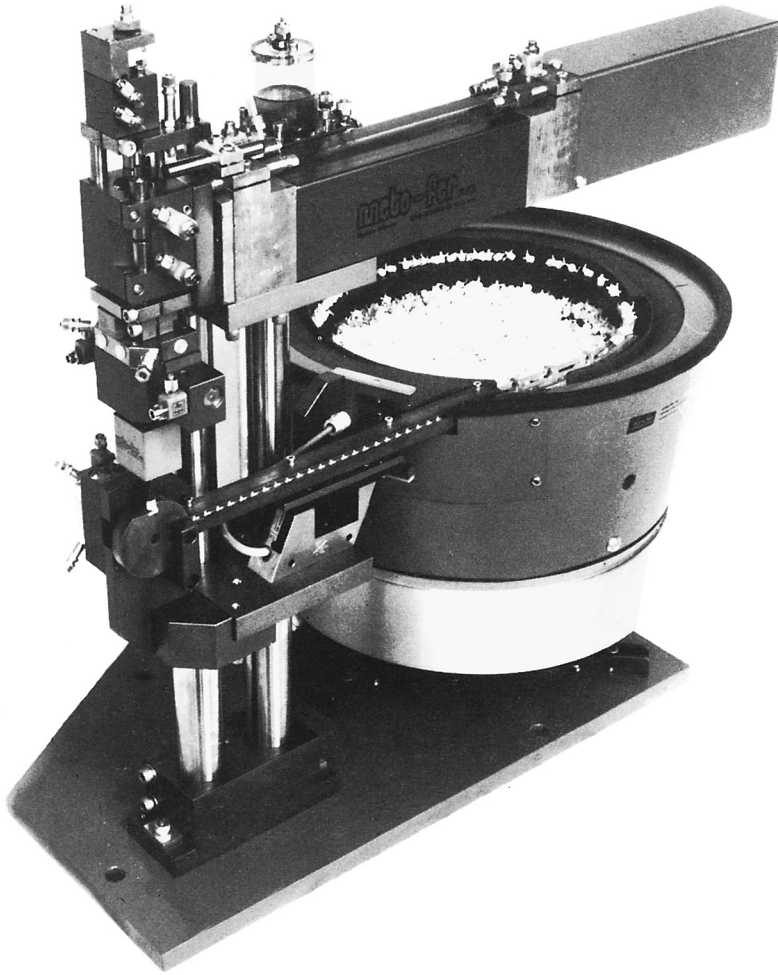

## Complete Pick and Place Station

- Linear Unit (LH), Vertical Unit (VE), Rotary Actuator (ZD12/180), Mechanical Gripper (ZZ12, MZ 12)
- Vibratory Feeder with incline track and Rotary Actuator with single escapement
- Standard modular components (no custom adapter plates needed)
- Stroke and rotation adjustable with stop screws (also used for output signal)
- Up to 25 million cycle times
- Seal / Bearing Kits available for all meto-fer components
- PLC for Pick and Place available

**For more information, call 412-488-3488; 1-888-METO-FER (1-888-638-6337)  
or visit our website: [www.meto-fer.com](http://www.meto-fer.com)**

**STOP SCREWS, SENSORS, CABLES, AND HEIGHT GAUGES**

**SECTION 8**

**meto-fer®**  
**automation**

Your complete source for industrial automation and electronics

**mf automation, inc.**

[www.meto-fer.com](http://www.meto-fer.com)

1-888-638-6337

# Table of Contents

	PAGE
<b>Sensor and Cable Reference Codes</b> .....	.1
<b>Namur, PNP, and NPN Information</b> .....	.2
<b>Precision Stop System with Sensing Element</b> .....	.3
<b>Marking of Cables and Connectors</b> .....	.4
<b>Inductive Proximity Switches</b>	
Size	
$\varnothing$ 3mm .....	.5
$\varnothing$ 4mm / 4mm x 4mm .....	.6
M5 x 0.5mm .....	.7
6mm x 6mm / $\varnothing$ 6.5 mm .....	.8
M8 x 1mm .....	.9
8mm x 8mm / M12 x 1mm .....	.10
M18 x 1mm .....	.11
<b>Sensing Elements</b>	
Type	
Electronic NAMUR (QE-AX)/Electronic LOGIC (QE-NS/ PS) .....	.12
Electo-mechanical (QE-EB)/Pneumatic (P) .....	.13
Stop Screws for Sensing Elements .....	.13
Stop Screws with Extended Stroke for Sensing Elements .....	.14
<b>Height Gauge</b> .....	.15

## Sensor reference codes

Designation	Casing form	Output technique	Switching function	Cable or connector	Status indicator	Option
<b>XX - XXX</b>	<b>X</b>	<b>X - XX</b>	<b>X - X</b>			
<b>IR</b> Inductive round <b>IM</b> Inductive quadratic <b>QE</b> Sensing elements <b>RL</b> Reflex light barrier	<b>003</b> Ø 3 mm <b>004</b> Ø 4 mm 4x4 mm <b>005</b> M5 <b>006</b> 6 x 6 mm <b>065</b> Ø 6.5 mm <b>008</b> 8 x 8 mm M8 x 1 <b>010</b> Ø 10 mm <b>012</b> M12 x 1 <b>018</b> M18 x 1 <b>022</b> 12 x 22 mm <b>812</b> 8 x 12 mm <b>525</b>	<b>A</b> Analog <b>N</b> NPN Output <b>P</b> PNP Output <b>E</b> Electromechanical <b>R</b> Controllable extern <b>D</b> Digital	<b>S</b> Normally open <b>O</b> Normally closed <b>H</b> Light on <b>D</b> Dark on <b>B</b> Normally open and Normally closed <b>X</b> Vacant	<b>U2</b> Cable PUR 2 meter <b>U5</b> Cable PUR 5 meter <b>U9</b> Cable PUR 9 meter <b>01</b> Connector Meto-Fer <b>02</b> Connector Meto-Fer threaded connection <b>10</b> 3-Channel connector <b>11</b> 3-Channel connector threaded connection <b>30</b> 4-Channel connector threaded connection	<b>L</b> with LED <b>0</b> without LED	<b>A</b> without corporate name Meto-FerElektronik AG

## Cable reference codes

Designation	Connector form	Number of leads	Cable cross section	Cable and length	Status indicator
<b>XX - XXX</b>	<b>-</b>	<b>X</b>	<b>X - XX</b>		<b>X</b>
<b>ST</b> Cable <b>01G</b> Meto-Fer connector straight <b>02G</b> Meto-Fer connector straight threaded connection <b>10G</b> 3 Channel connector straight <b>10W</b> 3 Channel connector right angle <b>11G</b> 3 Channel connector straight threaded connection <b>11W</b> 3 Channel connector right angle threaded connection <b>30G</b> 4 Channel connector straight threaded connection <b>30W</b> 4 Channel connector right angle threaded connection		<b>2</b> Lead <b>3</b> Lead <b>4</b> Lead	<b>A</b> 0.14 mm <b>B</b> 0.25 mm	<b>U2</b> Cable PUR 2 meter <b>U5</b> Cable PUR 5 meter <b>U9</b> Cable PUR 9 meter	<b>X</b> without LED

# NAMUR, PNP and NPN Information

NAMUR Proximity Switch:

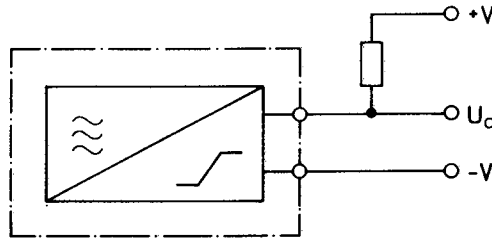

NAMUR-proximity switches have 2 wires which are connected to the supply with a current limiting resistor. The value of the limiting resistor depends on the supply voltage. According to NAMUR, the limiting resistor has a value of 1kOhm at a supply voltage of 8.2V (Temp = +20°C (+68°F)).

When the load is activated, the current consumption of the proximity switch is small; i.e. the voltage drop over the sensor element is large.

When the load is not activated, the current consumption of the proximity switch is large; i.e. the voltage drop over the sensor element is small.

Caution: A serial mounting of NAMUR proximity switches is not allowed!

LOGIC Proximity Switch:

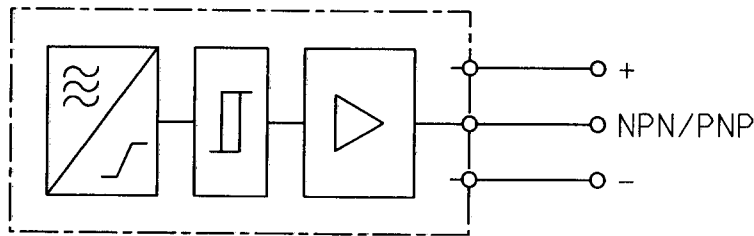

All logic proximity switches that are alternatively available in PNP or NPN version have 3 wires. The PNP-output signal is measured between the PNP-output wire and the negative-voltage supply-wire (blue). The NPN-output signal is measured between the NPN-output wire and the positive-voltage supply-wire (brown).

The parallel-, as well as the serial mounting of 3-wire or 4-wire proximity switches is allowed. The maximum number of serial mounted proximity switches varies depending on the value of the supply voltage and is limited by the value of the respective voltage drop of the elements.

# Precision Stop System With Sensing Element

For monitoring mechanical motions, Meto-Fer has a patented Stop System that provides fine stroke adjustment of the stop position and simultaneously provides an output in electrical, electronic, or pneumatic form to confirm that the stop position has been met.

Stop screw with locknut



Plug-in sensing element



## Functional Principle

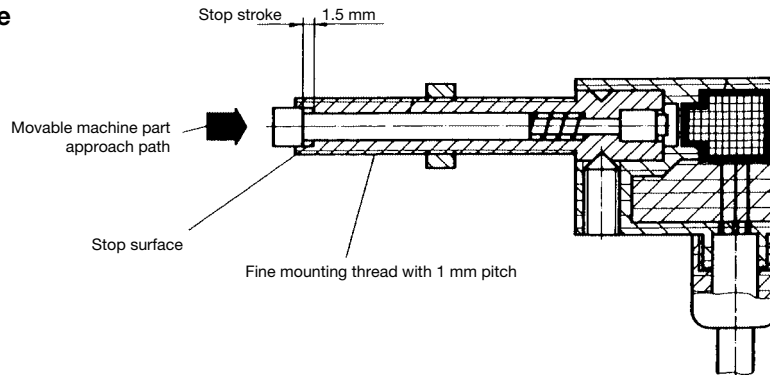

\* Please note additional information on page 12 / 13

- The stop screw is used to adjust the mechanical end-position of the motion.
- The fine thread of the stop screw allows exact adjustment of the mechanical end position. The locknut secures the adjusted position.
- The stop screw contains a spring and hardened stop pin, which operates the attached sensing element when the pin is driven to the end position.
- The stroke of the hardened stop striker is 1.5 mm.
- This combination eliminates the need for a secondary sensor adjustment after the hard stop adjustment has been made.
- They come standard on all our rotary and linear actuators, or they can be integrated into your design as stand alone products whenever precision feedback and adjustment are required.

## Stop Screw AS

Dimension					Part No.
A	B	C	L	LB (N)	
M8x1	5.5	1.5	15	450 (2,000 N)	AS 08/15
M8x1	5.5	1.5	40	450 (2,000 N)	AS 08/40
M10x1	7.5	2.5	50	2,135 (9,500 N)	AS 10/50
M12x1	9	2.5	60	4,600 (20,500 N)	AS 12/60
M12x1	9	2.5	80	4,600 (20,500 N)	AS 12/80
M18x1	14	2.5	100	10,100 (45,000 N)	AS 18/100
1/2-20	9	2.5	60	4,600 (20,500 N)	AS 1/2-20
5/16-24	5.5	1.5	40	450 (2,000 N)	AS 5/16-20

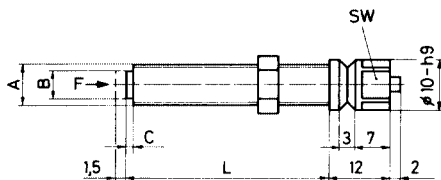

F = force or load (N)  $F = m \times a$   
 M = mass (kg)  $a = \text{acceleration (m/s)}$



# Marking of cables and connectors

Important: Sensors and cables have to be ordered separately. All the indicated part numbers of the sensors in the catalogue which do not have an incorporated cable refer only to the sensor - the corresponding cable is not included in this part-number

The corresponding cable has to be ordered separately according the following table.

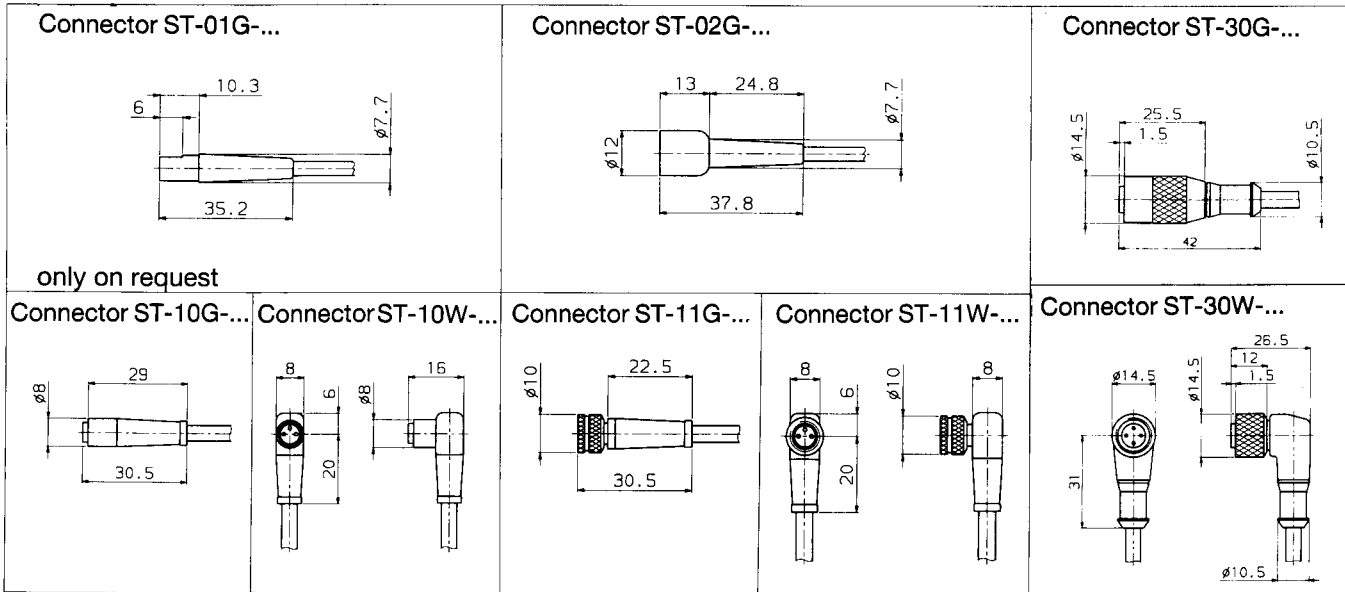

Part-Number of cables which correspond to the Meto-Fer connector 01 and 02 (cable cross section: 0.14mm<sub>2</sub>)

straight plug	
ST-02G-3A-U2X	U2X=2m
ST-02G-3A-U5X	U5X=5m
ST-02G-3A-U9X	U9X=9m

Part-Number of cables which correspond to the Standard-Connector 10 (cable cross section: 0.25mm<sub>2</sub>)

straight plug (NAMUR / LOGIC)	right angle plug (90°) (NAMUR / LOGIC)	Length
ST-10G-3B-U2X	ST-10W-3B-U2X	U2X=2m
ST-10G-3B-U5X	ST-10W-3B-U5X	U5X=5m
ST-10G-3B-U9X	ST-10W-3B-U9X	U9X=9m

Part-Number of cables which correspond to the Standard-Connector 11 (cable cross section: 0.25mm<sub>2</sub>)

straight plug (NAMUR / LOGIC)	right angle plug (90°) (NAMUR / LOGIC)	Length
ST-11G-3B-U2X	ST-11W-3B-U2X	U2X=2m
ST-11G-3B-U5X	ST-11W-3B-U5X	U5X=5m
ST-11G-3B-U9X	ST-11W-3B-U9X	U9X=9m

Part-Number of cables which correspond to the Standard-Connector 30 (cable cross section: 0.25mm<sub>2</sub>)

straight plug (NAMUR / LOGIC)	right angle plug (90°) (NAMUR / LOGIC)	Length
ST-30G-4B-U2X	ST-30W-4B-U2X	U2X=2m
ST-30G-4B-U5X	ST-30W-4B-U5X	U5X=5m
ST-30G-4B-U9X	ST-30W-4B-U9X	U9X=9m

- for non-contact detection of all ferrous- and non-ferrous metals
- highest precision
- smallest size
- flush mount
- easily mounted
- IP 67 system of protection
- LED status indicator

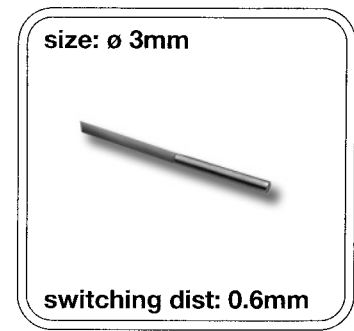

<p>Meto-Fer sensors meet and in most cases exceed the required minimal switching distances per DIN EN 50010</p>	<p><b>ø 3mm LOGIC</b></p>
<p>wiring diagram br = brown      sw = black bl = blue</p> <p>wires are color coded according to EN 50044</p>	 
<b>TECHNICAL DATA</b>	
switching hysteresis	<10%
repeatability	<0.01mm
supply voltage	10V.....30V DC
residual ripple per DIN 41755	20%
load current (-10%, +25%)	100mA
current drain, activated	<10mA
current drain, not activated	<2mA
overvoltage spike protection	yes
polarity protection	yes
short circuit protection / overvoltage protection	yes
switching function	normally open
output type	NPN or PNP
LED status indicator	yes
switching rate	3 kHz
operating temperature range	-20°C.....+70°C
casing material	metal
cable cross section	0.14mm <sup>2</sup>
cable: -standard PUR cable -special length on request	cable integral molded
system of protection per DIN 40050	IP 67
color of active surface	black

<p>remarks to the part-number</p>	<p><b>Part Number</b></p>
<p><b>Reference codes see page 1</b></p>	<p><b>IR-003-NS-U2L</b> <b>IR-003-PS-U2L</b></p>

size:  $\varnothing$  4mm



switching distance: 0.8mm

size: 4mm x 4mm



switching distance: 0.8mm

$\varnothing$ 4mm NAMUR	$\varnothing$ 4mm LOGIC	4 x 4mm NAMUR	4 x 4mm LOGIC
	<10%		<10%
<0.01mm	<0.01mm	<0.01mm	<0.01mm
5V.....24 V DC	8V.....30V DC	5V.....24V DC	8V.....30V DC
10%	10%	10%	10%
	200mA		200mA
<1mA	<15mA	<1mA	<15mA
<4mA	<2mA	<4mA	<2mA
	yes		yes
	yes		yes
	yes		yes
analog	normally open	analog	normally open
Namur per DIN 19234	NPN or PNP	Namur per DIN 19234	NPN or PNP
	yes		yes
2 kHz	2 kHz	2 kHz	2 kHz
-20°C.....+70°C	-20°C.....+70°C	-20°C.....+70°C	-20°C.....+70°C
metal	metal	metal	metal
0.14mm <sup>2</sup>	0.14mm <sup>2</sup>	0.14mm <sup>2</sup>	0.14mm <sup>2</sup>
cable integral molded	cable integral molded	cable integral molded	cable integral molded
IP 67	IP 67	IP 67	IP 67
NAMUR = blue	NPN = red / PNP = green	NAMUR = blue	NPN = red / PNP = green

Part Number	Part Number	Part Number	Part Number
IR-004-AX-U20	IR-004-NS-U2L IR-004-PS-U2L	IM-004-AX-U20	IM-004-NS-U2L IM-004-PS-U2L

Reference codes see page 1

- for non-contact detection of all ferrous- and non-ferrous metals
- highest precision
- smallest size
- large switching distances
- easily mounted
- IP 67 system of protection (plug: IP 65)
- LED status indicator

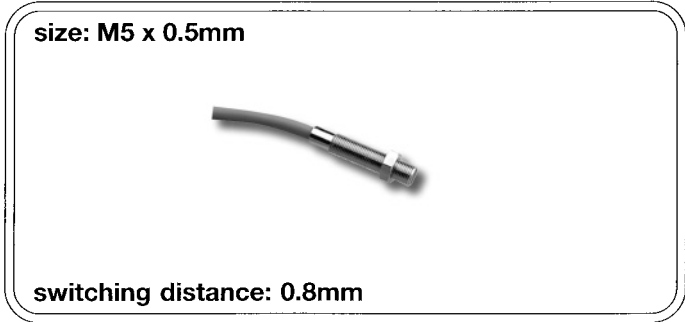

	M5 x 0.5mm NAMUR	M5 x 0.5mm LOGIC
Meto-Fer sensors meet and in most cases exceed the required minimal switching distances per DIN EN 50010		
wiring diagram br = brown sw = black we = white bl = blue  wires are color coded according to EN 50044		
<b>TECHNICAL DATA</b>		
switching hysteresis		<10%
repeatability	<0.01mm	<0.01mm
supply voltage	5V.....24V DC	8V.....30V DC
residual ripple per DIN 41755	10%	10%
load current (-10%, +20%)		200mA
current drain, activated	<1mA	<15mA
current drain, not activated	<4mA	<2mA
overvoltage spike protection		yes
polarity protection		yes
short circuit protection / overvoltage protection		yes
switching rate	analog	normally open (NO)
output type	NAMUR per DIN 19234	NPN or PNP
LED status indicator		yes
switching rate	2 kHz	2 kHz
operating temperature range	-20°C.....+70°C	-20°C.....+70°C
casing material	metal	metal
cable cross section	0.14mm <sup>2</sup>	0.14mm <sup>2</sup>
cable: -PUR cable is standard -cable has to be ordered separately (page 12)	integral molded cable	integral molded cable
system of protection per DIN 40050	IP 67	IP 67
color of the active surface	NAMUR = blue	NPN = red / PNP = green

remarks to the part number	Part Number	Part Number
<b>Reference codes see page 1</b>	<b>IR-005-AX-U20</b>	<b>IR-005-NS-U2L IR-005-PS-U2L</b>

size: 6 x 6mm



switching distance: NAMUR 1.5mm / Logic 2mm

size: ø 6.5mm



switching distance: NAMUR 1.5mm / Logic 2mm

6 x 6mm NAMUR	6 x 6mm LOGIC	ø 6.5mm NAMUR	ø 6.5mm LOGIC
	<10%		<10%
<0.01mm	<0.01mm	<0.01mm	<0.01mm
5V.....24V DC	8V.....30V DC	5V.....24V DC	8V.....30V DC
10%	10%	10%	10%
	200mA		200mA
<1mA	<15mA	<1mA	<15mA
<4mA	<2mA	<4mA	<2mA
	yes		yes
	yes		yes
	yes		yes
analog	normally open	analog	normally open
Namur per DIN 19234	NPN or PNP	Namur per DIN 19234	NPN or PNP
			yes (plug version only)
2 kHz	2 kHz	2 kHz	2 kHz
-20°C.....+70°C	-20°C.....+70°C	-20°C.....+70°C	-20°C.....+70°C
metal	metal	metal	metal
0.14mm <sup>2</sup>	0.14mm <sup>2</sup>	0.14mm <sup>2</sup>	0.14mm <sup>2</sup>
integral molded cable	integral molded cable	integral molded cable or connector (see page 12)	integral molded cable or connector (see page 12)
IP 67	IP 67	IP 67 (with plug = IP 65)	IP 67 (with plug = IP 65)
Namur = blue	NPN = red / PNP = green	Namur = blue	NPN = red / PNP=green

Part Number	Part Number	Part Number	Part Number
IM-006-AX-U20	IM-006-NS-U2L IM-006-PS-U2L	IR-065-AX-U20 IR-065-AX-010 IR-065-AX-100	IR-065-NS-10L IR-065-PS-10L IR-065-NS-01L IR-065-PS-01L IR-065-NS-U2L IR-065-PS-U2L

Reference codes see page 1

- for non-contact detection of all ferrous- and non-ferrous metals
- highest precision
- easily mounted
- large switching distances
- cable- and plug version
- IP 67 system of protection (plug version: IP 65)
- LED status indicator

size: M8 x 1mm



switching dist: NAMUR = 1.5mm / Logic = 2mm

	M8 x 1mm NAMUR	M8 x 1mm LOGIC
Meto-Fer sensors meet and in most cases exceed the required minimal switching distances per DIN EN 50010		
wiring diagram br = brown    sw = black we = white    bl = blue		
wires are color coded according to EN 50044		
<b>TECHNICAL DATA</b>		
switching hysteresis		<10%
repeatability	<0.01mm	<0.01mm
supply voltage	5V.....24V DC	8V.....30V DC
residual ripple per DIN 41755	10%	10%
load current (-10%, +20%)		200mA
current drain, activated	<1mA	<15mA
current drain, not activated	<4mA	<2mA
overvoltage spike protection		yes
polarity protection		yes
short circuit protection / overvoltage protection		yes
switching protection	analog	normally open
output type	NAMUR per DIN 19234	NPN or PNP
LED status indicator		yes (plug version)
switching rate	2 kHz	2 kHz
operating temperature range	-20°C.....+70°C	-20°C.....+70°C
casing material	metal	metal
cable cross section	0.14mm <sup>2</sup>	0.14mm <sup>2</sup>
cable: -PUR cable is standard -cable has to be ordered separately ( page4 )	integral molded cable or connector (see page 4 )	integral molded cable or connector (see page 4 )
system of protection per DIN 40050	IP 67 (plug version =IP 65)	IP 67 (plug version =IP 65)
color of the active surface	NAMUR = blue	NPN = red / PNP = green
remarks to the part number	<b>Part Number</b>	<b>Part Number</b>
<b>Reference codes see page 1</b>	IR-008-AX-U20 IR-008-AX-010 IR-008-AX-110	IR-008-NS-11L IR-008-PS-11L IR-008-NS-01L IR-008-PS-01L IR-008-NS-U2L IR-008-PS-U2L

size: 8 x 8mm

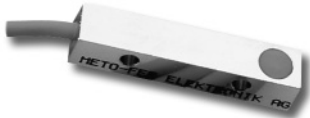

switching distance: NAMUR = 1.5mm / Logic = 2mm

size: M12 x 1mm



switching distance: NAMUR = 3mm / Logic = 3mm

8 x 8mm NAMUR		8 x 8mm LOGIC		M12 x 1mm NAMUR		M12 x 1mm LOGIC	
U20		U20		U20		U20	
01		01		02		02	
10		10		30		30	
		<10%				<10%	
<0.02mm		<0.02mm		<0.05mm		<0.05mm	
5V.....24VDC		8V.....30V DC		5V.....24V DC		8V.....30V DC	
10%		10%		10%		10%	
		200mA				200mA	
<1mA		<15mA		<1mA		<15mA	
<4mA		<2mA		<4mA		<2mA	
		yes				yes	
		yes				yes	
		yes				yes	
analog		normally open		analog		normally open/closed	
Namur per DIN 19234		NPN or PNP		Namur per DIN 19234		NPN or PNP	
		yes (plug version)				yes (plug version)	
1 kHz		1 kHz		1 kHz		1 kHz	
-20°C.....+70°C		-20°C.....+70°C		-20°C.....+70°C		-20°C.....+70°C	
metal		metal		metal		metal	
0.14mm <sup>2</sup>		0.14mm <sup>2</sup>		0.14mm <sup>2</sup>		0.14mm <sup>2</sup>	
integral cable or cable with connector (see page 4 )		integral cable or cable with connector (see page 4 )		integral cable or cable with connector (see page 4 )		integral cable or cable with connector (see page 4 )	
IP 67 (with plug = IP 65)		IP 67 (with plug = IP 65)		IP 67 (with plug = IP 65)		IP 65 (with plug = IP 65)	
NAMUR = blue		NPN = red / PNP = green		NAMUR = blue		NPN = red / PNP = green	

Part Number	Part Number	Part Number	Part Number
IM-008-AX-100	IM-008-NS-10L	IR-012-AX-U20	IR-012-NB-30L
IM-008-AX-010	IM-008-PS-10L	IR-012-AX-300	IR-012-PB-30L
IM-008-AX-U20	IM-008-NS-01L	IR-012-AX-020	IR-012-NS-02L
	IM-008-PS-01L		IR-012-PS-02L
	IM-008-NS-U2L		IR-012-NS-U2L
	IM-008-PS-U2L		IR-012-PS-U2L

Reference codes see page 1

- for non-contact detection of all ferrous- and non-ferrous metals
- highest precision
- large switching distances
- plug version (IP 65)
- easily mounted
- LED status indicator



<p>Meto-Fer sensors meet and in most cases exceed the required minimal switching distances per DIN EN 50010</p>	<b>M 18 x 1mm LOGIC</b>				
	<table border="1" style="width: 100%;"> <tr> <td style="text-align: center; vertical-align: middle;">02</td> <td style="text-align: center;"> </td> </tr> <tr> <td style="text-align: center; vertical-align: middle;">30</td> <td style="text-align: center;"> </td> </tr> </table>	02		30	
02					
30					
<p>wiring diagram                  br = brown    sw = black                  we = white    bl = blue</p> <p>wires are color coded according to EN 50044</p>	<table border="1" style="width: 100%;"> <tr> <td style="text-align: center;"> </td> <td style="text-align: center;"> </td> </tr> <tr> <td style="text-align: center;"> </td> <td style="text-align: center;"> </td> </tr> </table>				
<b>TECHNICAL DATA</b>					
switching hysteresis	<10%				
repeatability	<0.1mm				
supply voltage	8V.....30V DC				
residual ripple DIN 41755	10%				
load current (-10%, +25%)	200mA				
current drain, activated	<15mA				
current drain, not activated	<2mA				
overvoltage spike protection	yes				
polarity protection	yes				
short circuit protection / overvoltage protection	yes				
switching function	normally open/closed				
output type	NPN or PNP				
LED status indicator	yes				
switching rate	500 Hz				
operating temperature range	-20°C.....+70°C				
casing material	metal				
cable cross section					
cable: - cable has to be ordered separately (see page 4 )					
system of protection per DIN 40050	IP 65				
color of active surface (NPN = red / PNP = green)	depend on output function				
<b>remarks to the part number</b>	<b>Part-Number</b>				
<b>Reference codes see page 1</b>	<b>IR-018-NB-30L</b> <b>IR-018-PB-30L</b> <b>IR-018-NS-02L</b> <b>IR-018-PS-02L</b>				



- mechanically adjust stroke limit with electronic or pneumatic sensing device
- element can be plugged on
- Type ..-NS,-PS.: sense with inductive proximity switch
- Type ..-EB: electro-mech. switch
- Type P: 3/2 directional control valve

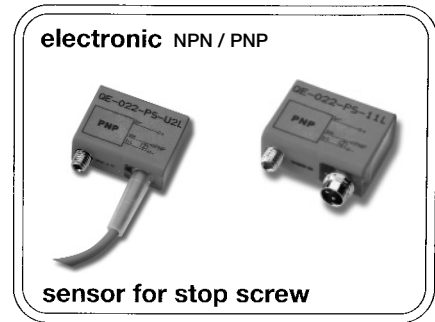
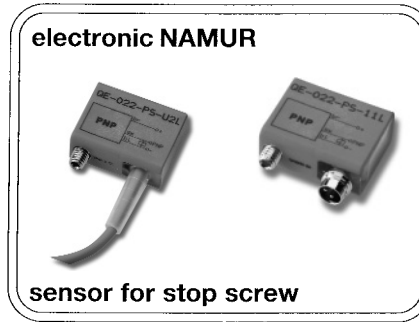

Plug on to any stop screw and secure with set screw.	22 x 12mm NAMUR	22 x 12mm LOGIC
		<p>U20</p>
wiring diagram br = brown    sw = black we = white    bl = blue  wires are color coded according to EN 50044		
<b>TECHNICAL DATA</b>		
supply voltage	5V.....24V DC	8V.....30V DC
residual ripple per DIN 41755	10%	10%
load current		200mA
current drain, activated	<1mA	<15mA
current drain, not activated	<4mA	<2mA
Max. switching current (AC and DC)		
Max. switching voltage DC		
Max. switching voltage AC		
polarity protection		yes
short circuit prot. / overvoltage prot.		yes
switching function	analog	normally open
output type	NAMUR	NPN or PNP
LED status indicator		yes
switching rate	2 kHz	2 kHz
operating temperature range	-20°C.....+70°C	-20°C.....+70°C
casing material	plastic	plastic
cable cross section	0.14mm <sup>2</sup>	0.14mm <sup>2</sup>
cable: -PUR cable is standard -cable info - (see page 4 )	integral molded cable or cable with plug (see page 4 )	integral molded cable or cable with plug (see page 4 )
system of protection per DIN 40050	IP 67 (plug version = IP 65)	IP 67 (plug version = IP 65)
signal transmitter	stop screw	stop screw

remarks to the part number	Part Number	Part Number Sensor	Cable (2m.6FT) <small>*5m and 9m also available</small>
<b>Reference codes see page 1</b>	<b>QE-022-AX-110</b> <b>QE-022-AX-020</b> <b>QE-022-AX-U20</b>	<b>QE-022-NS-11L</b> <b>QE-022-PS-11L</b> <b>QE-022-NS-02L</b> <b>QE-022-PS-02L</b> <b>QE-022-NS-U2L</b> <b>QE-022-PS-U2L</b>	<b>ST-11G-3B-U2X</b> <b>ST-02G-3A-U2X</b> <b>INTEGRAL MOLDED CABLE</b>

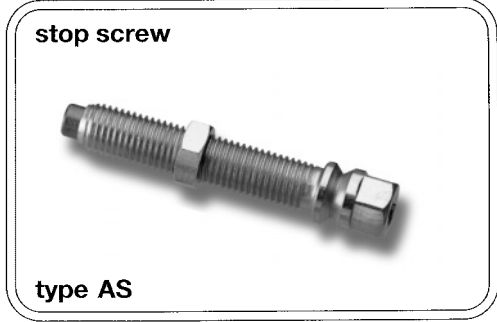
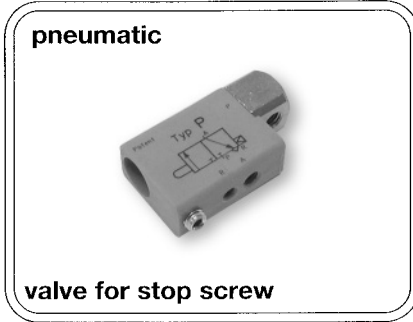
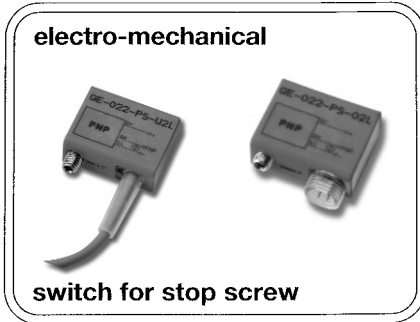

**electro-mechanical**

U20/02

1.5 A  
48 VDC  
230 VAC ( only for cable version)

change over contact  
el. mechanical change over switch

20 Hz  
-20C.....+70C

plastic

0.14mm<sup>2</sup>

3-wire cable integral molded  
or cable with plug

IP 41

stop screw

**type P = pneumatic**

supply pressure P = 1 - 8 bar  
signal pressure A = P  
nominal width NW = 2.5mm  
pneumatic connection = M5

plastic

stop screw

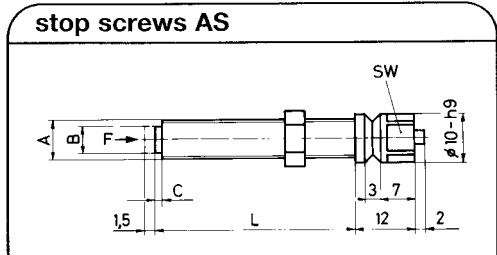

dimensionen					Part No.
A	B	C	L	F max.	
M8x1	5.5	1.5	15	2000N	<b>AS 08/15</b>
M8x1	5.5	1.5	40	2000N	<b>AS 08/40</b>
M10x1	7.5	2.5	50	9500N	<b>AS 10/50</b>
M12x1	9	2.5	60	20500N	<b>AS 12/60</b>
M12x1	9	2.5	80	20500N	<b>AS 12/80</b>
M18x1	14	2.5	100	45000N	<b>AS 18/100</b>

F = force or load (N) F = m x a  
m = mass (kg)  
a = acceleration (m/s<sup>2</sup>)

**spherical head type AK 40 for operating the stop screw AS 08/40 at an off centre angle**

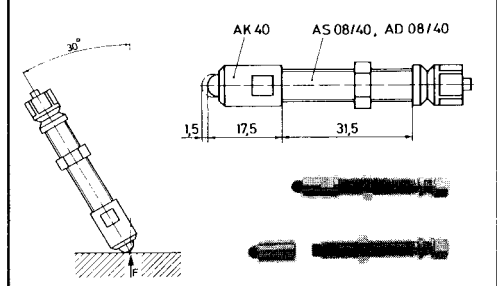

**Part Number: AK 40**

**nuts with fine-pitch thread**

dimensionen			Part No.
A	B	C	
M5x0.5	2.5	8	<b>MU 01.001</b>
M6x0.5	2.5	8	<b>MU 01.002</b>
M8x1	4	10	<b>MU 01.003</b>
M10x1	4	13	<b>MU 01.004</b>
M12x1	4	15	<b>MU 01.005</b>
M14x1	4	16	<b>MU 01.006</b>
M18x1	6	22	<b>MU 01.007</b>

Part Number	Cable (2m.6FT)	Part Number
<i>*5m and 9m also available</i>		
<b>QE-022-EB-110</b>	<b>ST-11G-3B-U2X</b>	<b>P</b> the pneumatic element is available in one type only
<b>QE-022-EB-020</b>	<b>ST-02G-3A-U2X</b>	
<b>QE-022-EB-U20</b>	<b>INTEGRAL MOLDED CABLE</b>	

Reference codes see page 1

# StopScrew AS (with extended stroke)

Use of the StopScrew with Extended Stroke and the QE-OSN-PS-11L Sensing Unit (see QE022-PS-11L data on page 12) enables achievement of shorter cycle times.

Depending on designated stroke (5, 10 or 20mm) the signal is advanced accordingly by 5, 10 or 20mm before the end stop. (The signal will be held).

Early signal compensation will be allowed for the start delay of a motion (approx. 0.1 sec.) through values and air flow.

Motion Example:

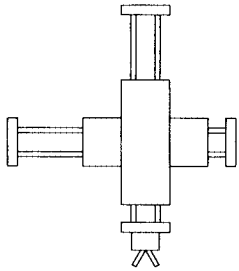

Motion Curve  
"AS Standard  
StopScrew"



Motion Curve  
"AS StopScrew with  
Extended Stroke"

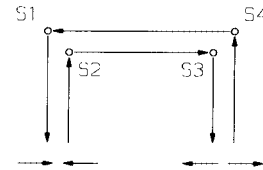

Example of 4 Cycle Positions (S1, S2, S3, S4) with time savings

**Time savings of approx. 0.5 sec.**

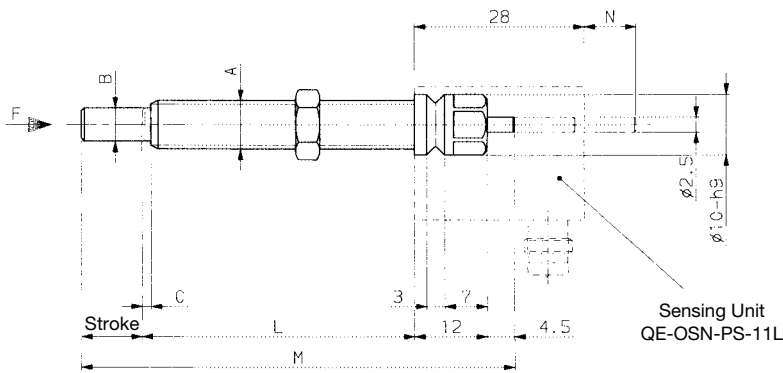

Sensing Unit  
QE-OSN-PS-11L

A	B	C	L	Stroke	M	N	F [N]		Order No.
							min.	max.	
M8x1	5.5	1.5	45	10	71.5	-	6	2000	AS08/45-10
M10x1	7.5	2.5	50	10	76.5	-	10	9500	AS10/50-10
M12x1	9.0	2.5	60	10	86.5	-	10	20500	AS12/60-10

Sensing Unit



**Order No:**  
QE-OSN-PS-11L

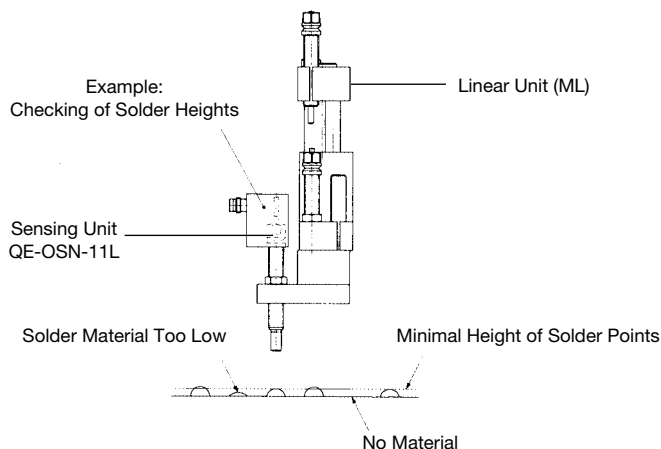

# Height Gauge KV (precision sensing unit)

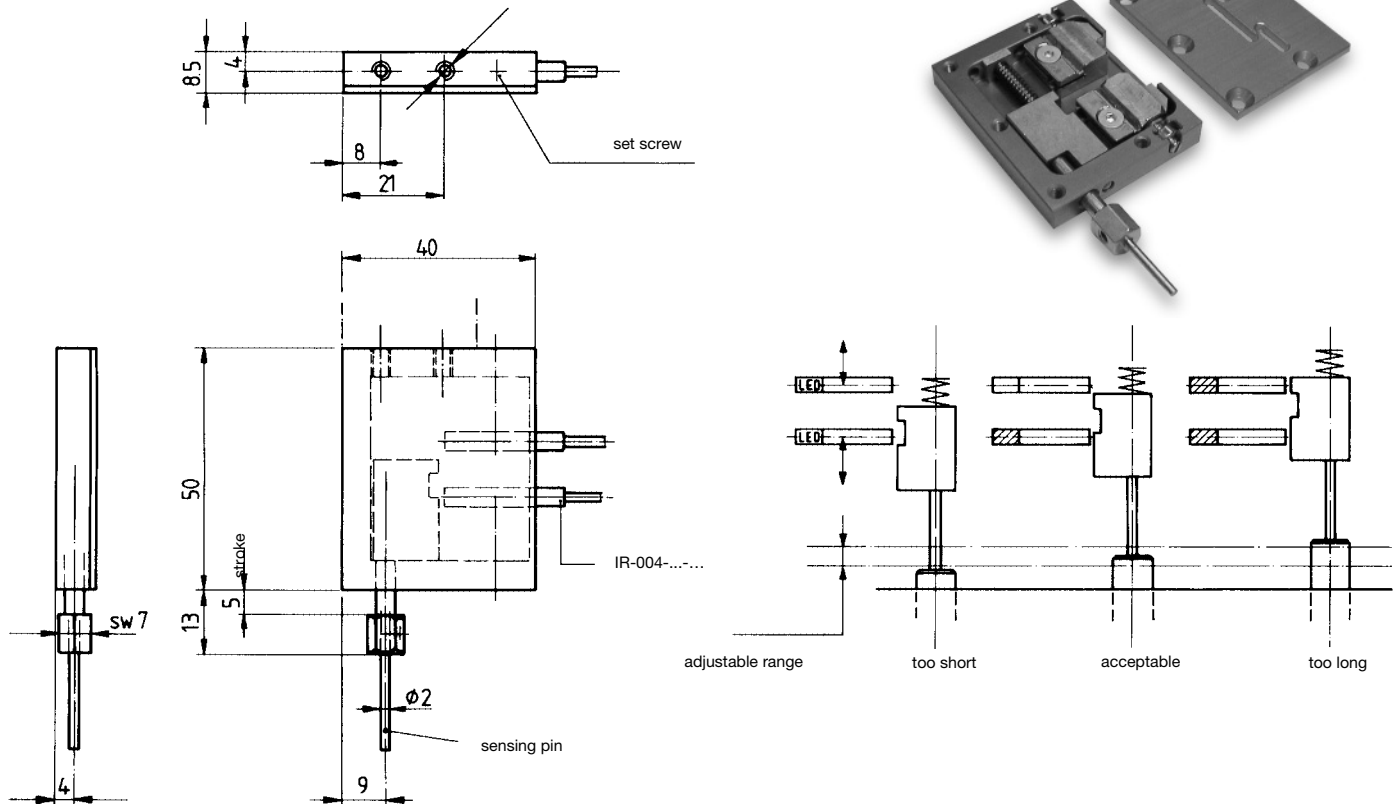

## Application:

- Tolerance control with output signal for too short, acceptable, too long
- Check for failure
- Presence control

The height gauge KV is used for the control of two adjustable positions with a range from 0.03 to 5 mm.

Whenever precision feedback and adjustment are required.  
Output signal; when the preset limiting values are reached.

## Order No.

**KV 01- ...**

O-without proximity switches

A-with 2 inductive proximity switches IR-004-NS-U2L (NPN, normally open)

B-with 2 inductive proximity switches IR-004-PS-U2L (PNP, normally open)

C-with 2 inductive proximity switches IR-004-AX-U20 (NAMUR, analog)

\*All proximity switches have molded cable, see page 6

## Technical data:

- Control range is adjustable with two set screws (sensor position 1 and 2)
- Adjustable range: 0.03 - 5 mm (0.00118-0.196 inch)
- Spring force: 140 - 210 g (0.308-0.463 lb)
- Repeatability: +/- 0.03 mm (+/-0.00118 inch)
- Weight: 0.07 kg (0.154 lb)
- For horizontal and vertical applications

# LINEAR TRANSFER SYSTEMS

SECTION 10



Your complete source for industrial automation and electronics

**mf automation, inc.**

[www.meto-fer.com](http://www.meto-fer.com)

1-888-638-6337

# Linear Transfer System MP

## Linear Pallet Transfer System Two-Belt System

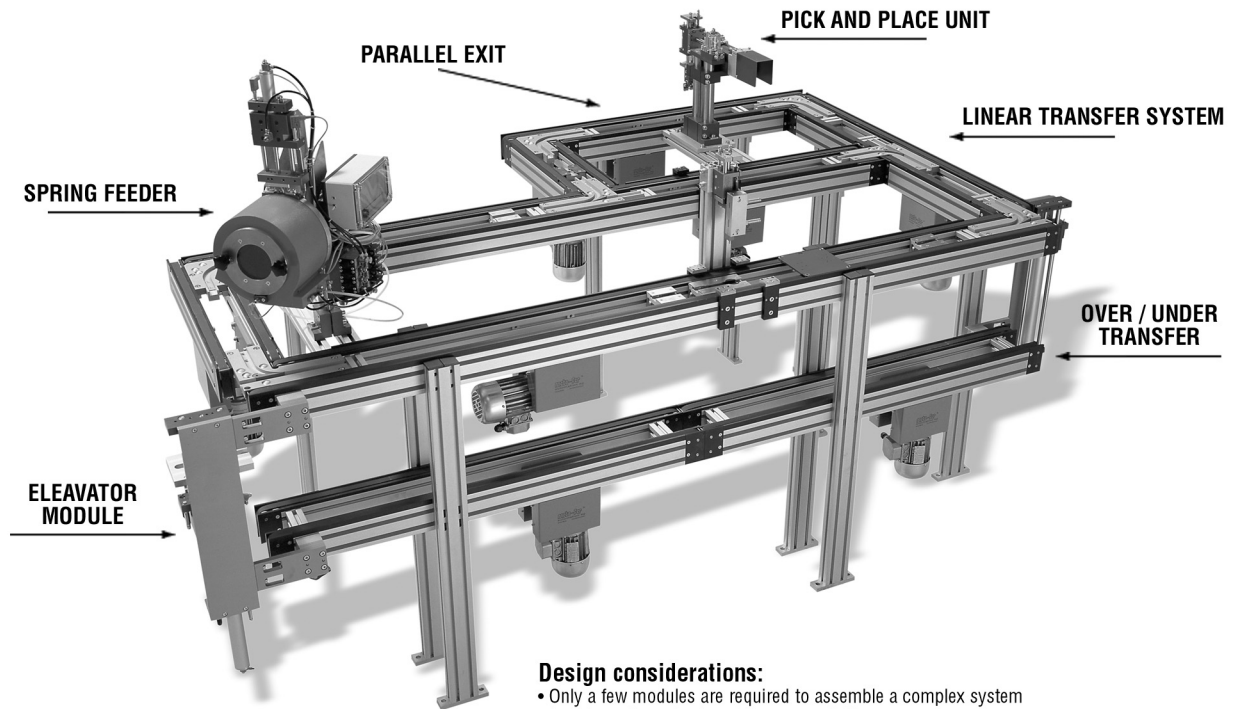

### Design considerations:

- Only a few modules are required to assemble a complex system
- A variety of standard modules are available
- The MP System supports manual, semi-automatic or fully automatic operation
- The MP System can be easily expanded and all modules can be entirely re-used
- The MP System facilitates fast and reliable transport of aluminum pallets
- Any number of manual work modules can be directly integrated into the main system



Switch Point



Partial Track Connection

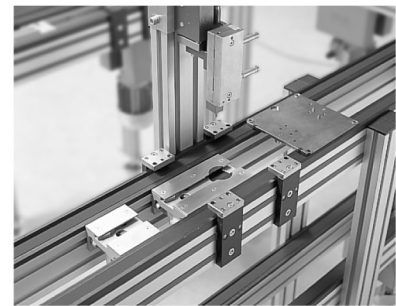

Position Station



Partial Track with Drive Unit





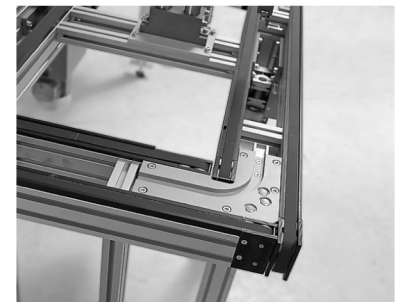

Vertical End Module with Lift



End Module

See web page: [www.meto-fer.com/2LTSSub.html](http://www.meto-fer.com/2LTSSub.html)

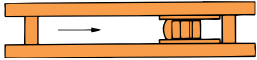
## Following is the list of components used in the Modular Assembly System:

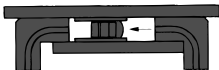
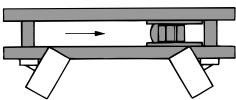
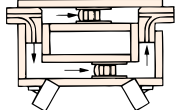
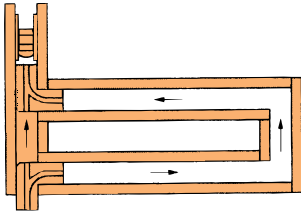
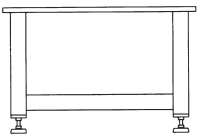
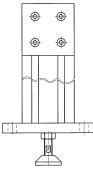
	Component No.	Page No.
Pallet (Coding "MC") 	① ② MPA-010-xxx-xxx ① = Pallet Length in mm ② = Pallet Width in mm	10.003
Positioning for automation workstation/manual workstation 	MPA-020-xxx-xxx MPA-025-xxx-xxx	10.004
Partial transport tracks 	MPA-030-xxx-xxx	10.005
Connecting transport tracks 	MPA-040-xxx-xxx MPA-045-xxx-xxx	10.005
End modules 	MPA-050-xxx-xxx MPA-051-xxx-xxx	10.006
Manual workstation A (in line) 	MPA-060-xxx-xxx	10.006
Manual workstation B (parallel exit) 	MPA-070-xxx-xxx	10.007
Manual workstation C (perpendicular exit) 	MPA-080-xxx-xxx	10.007
Base table 	MPA-090-xxx-xxx MPA-091-xxx-xxx MPA-092-xxx-xxx MPA-093-xxx	10.008
Support stands 	MPA-110-xxx	10.008

# Combination Examples of MP Systems

EXAMPLE 1

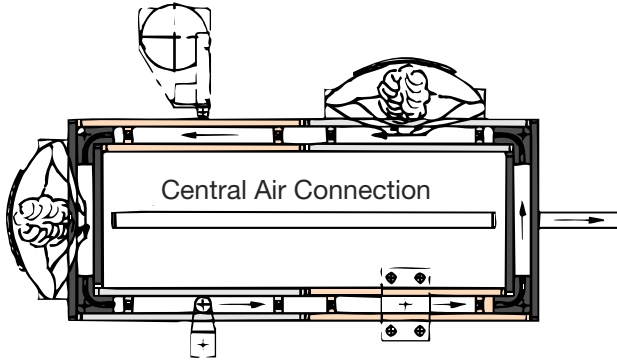

EXAMPLE 2

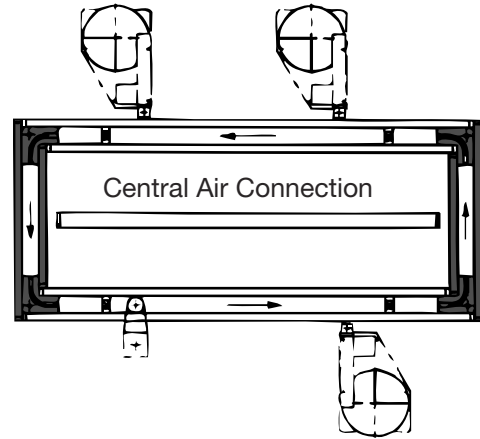

EXAMPLE 3

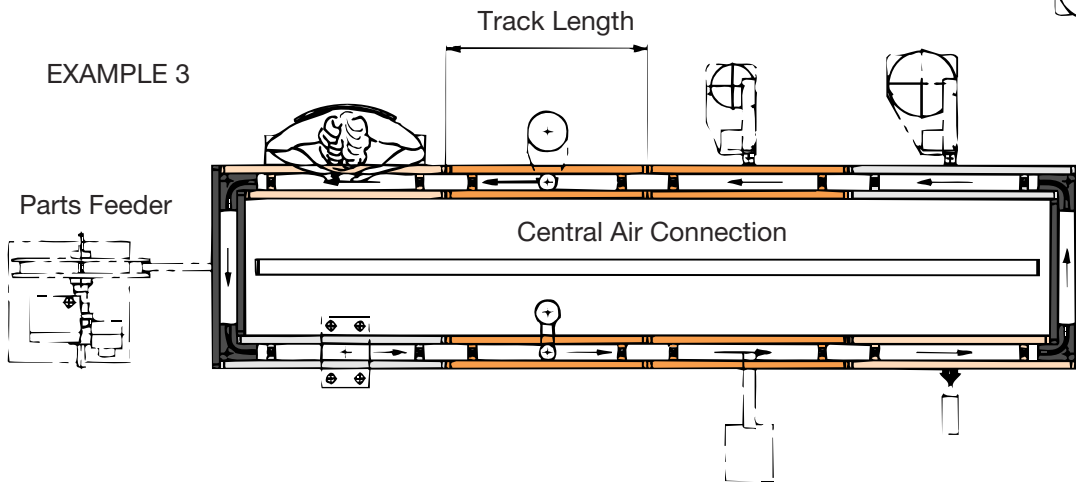

EXAMPLE 4

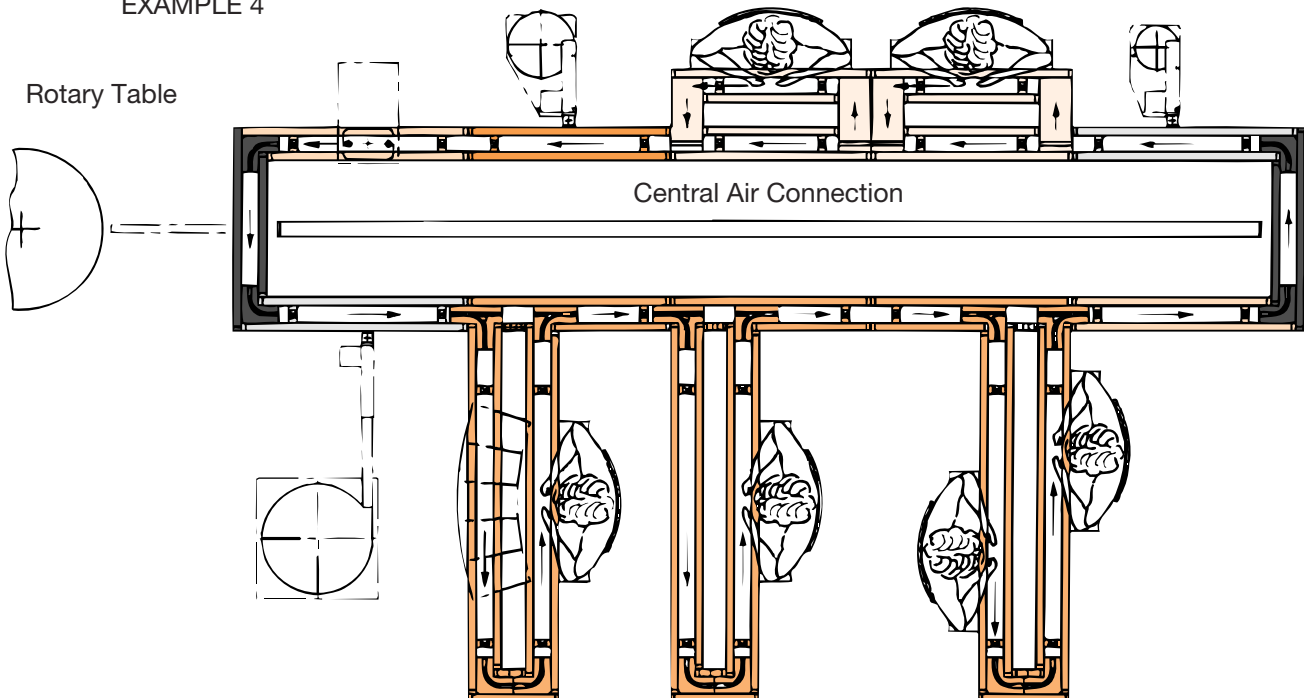



**INQUIRY SHEET: Pallet / Chain Transporter or MP-System (2 belt)**

COMPANY: \_\_\_\_\_ PHONE: \_\_\_\_\_

CONTACT NAME: \_\_\_\_\_ FAX: \_\_\_\_\_

ADDRESS: \_\_\_\_\_ EMAIL: \_\_\_\_\_

CITY / STATE / ZIP: \_\_\_\_\_

**SYSTEM DATA INFO:**

Approximate Length of system: \_\_\_\_\_

Approximate Width of system: \_\_\_\_\_

Dimensions of product to be handled:

Length: \_\_\_\_\_

Width: \_\_\_\_\_

Height: \_\_\_\_\_

Weight of product: \_\_\_\_\_

Weight of work piece holder per pallet: \_\_\_\_\_

Pallet size: Length: \_\_\_\_\_

Width: \_\_\_\_\_

Number of Pallets: \_\_\_\_\_

Chain/Belt Speed: \_\_\_\_\_

Direction of travel:  Clockwise  Counter clockwiseIncluding proximity switch:  YES  NO  NPN or  PNP

Automatic Workstation: (1pc. Pre-stop, 1pc. Stop, 1pc. lift) \_\_\_\_\_ pc. (+ / - 0.02 mm accuracy)

Manual Workstation: (1pc. Pre-stop and 1pc. Stop) \_\_\_\_\_ pc. (+ / - 0.5 mm accuracy)

Height of system: \_\_\_\_\_ (Top of Chain/Belt)

Coding systems:  YES  NO

Additional comments:

---



---



---

PLEASE SEND OR FAX INQUIRY REQUEST TO:

mf automation, Inc.  
 355 Wyoming Street • Pittsburgh, PA 15211  
 Phone: 412-488-3488  
 Fax: 412-488-3498

## Pallets

- The pallets provide a platform for fixtures and coding system.
- Meto-Fer® offers a mechanical coding system ("MC").
- The positioning accuracy of the pallets is 0.02mm (standard).  
Option: Positioning accuracy for pallet size up to 200 x 200 mm, 0.01mm.
- The wide range of pallets allows for optimal adaptation to your product.

### Standard Sizes

Pallet Size AxB	C	D	Pallet Interchange Time (sec.)	Material
150x100	82	10	1.2	Aluminum (AlMg4.5Mn No. 5083)
150x150	120	10	1.2	
200x150	120	10	1.4	
200x200	170	10	1.4	
250x200	170	10	1.6	
250x250	220	10	1.6	
300x200	170	10	1.8	
300x300	270	10	1.8	
400x300	270	10	2.2	
400x400	370	10	2.2	
500x400	370	10	2.6	
500x500	470	10	2.6	

Option up to 1,500 x 1,000mm possible

### Recommendation for number of pallets per systems:

3 pcs. per station + an additional 6 pcs.

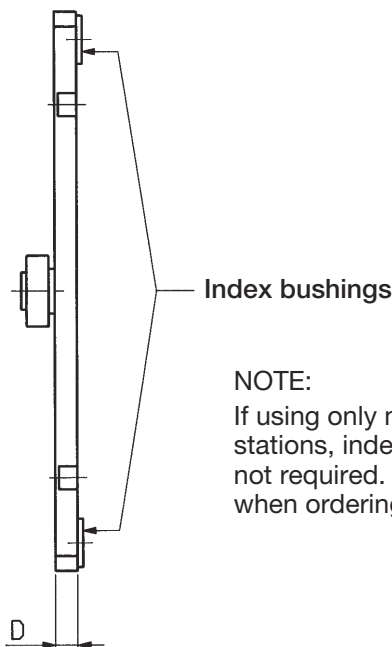

NOTE:  
If using only manual workstations, index bushings are not required. Please specify when ordering.

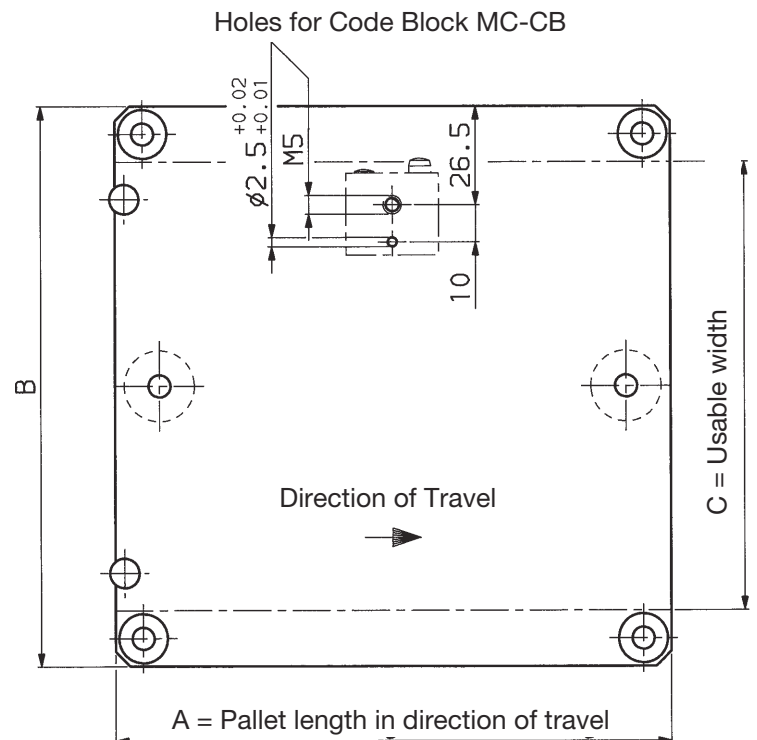

Order No.      for Pallets

MPA-010-xxx-xxx

① = Pallet Length in mm  
② = Pallet Width in mm

## Mechanical Coding System MC

The Coding System transfers information regarding the status of assembly, such as:

- acceptable / failure
- part present/not present
- status of process
- transportation destination (exit, straight forward)

### Coding Block: Type MC-CB

This is the information carrier about the status of the work piece which circulates on the MP-System from station to station. In each coding block are 2 coding pins. One pin is for the "Set", the other for the "Read" and reserve. The mechanical coding system requires that each pallet is equipped with a minimum of one coding block. Several coding blocks can be mounted next to each other.

Order No. MC-CB-01-06

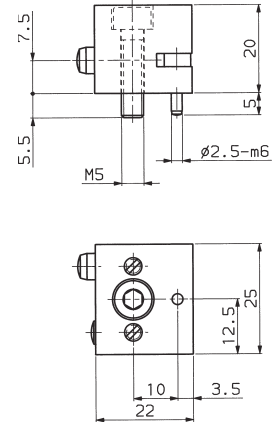

### Coding Setter: Type MC-CS

The Coding Setter serves to "Set" and "Reset" of the coding pin. It consists of a single acting cylinder which is mounted to the MP-profile by an adapter. To "Set" the coding pin, the pallets have to be stopped.

Pallet Thickness—D	L	A
10	121	61.5

Air consumption per stroke 0.1 ml

Amount: 1 pc. per station

Order No. MC-CS-01-10 (for pallet thickness 10mm)

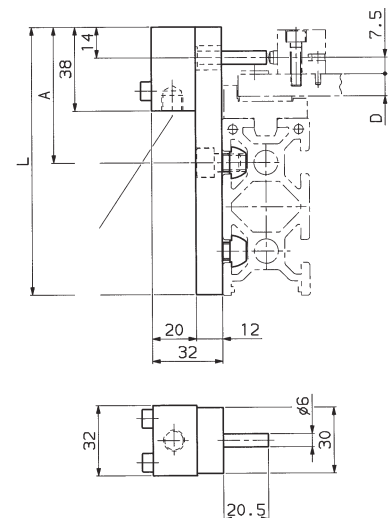

### Code Reader: Type MC-CL

The code reader is used to read the coding pins. The reading is done by inductive proximity switch with LED display.

Pallet Thickness—D	L	A
10	102	42.5

Amount: 1 pc. per station

Order No. MC-CL-01-10 (for pallet thickness 10mm)

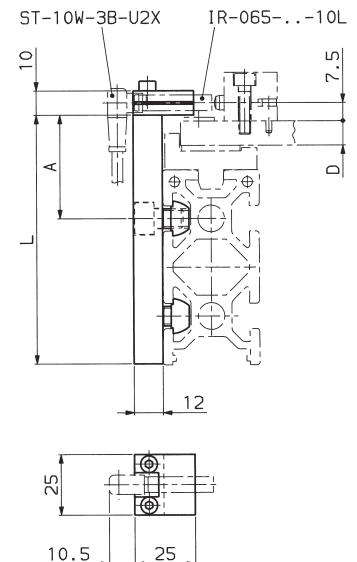

**NOTE:** Sensors and cables are not included with the pallet system and need to be ordered separately.

Sensor: Order No. IR-065-NS-10L (NPN) or IR-065-PS-10L (PNP)

Cable: Order No. ST-10W-3B-U2X (2m) ST-10W-3B-U5X (5m)

## Positioning (Automatic Workstation)

- For accurate positioning, the pallets are lifted from the transport belts and positioned with pins/cones.
- The positioning accuracy is +/- 0.02mm in the standard version. We offer options up to 200 x 200 pallet size with a positioning accuracy of +/- 0.01mm.
- The positionings can be fixed at any place over the entire length of the lateral transport without any mechanical modifications.
- 2 or more workstations can be set up per partial lateral transport.
- The pallets are cushioned in the end position.
- If required, positioning stations are available for:
  - access from underneath (working from below possible)
  - the pallet supported from underneath (press from above possible)
  - the pallet to be changed by quick exchange (short pallet changing times)

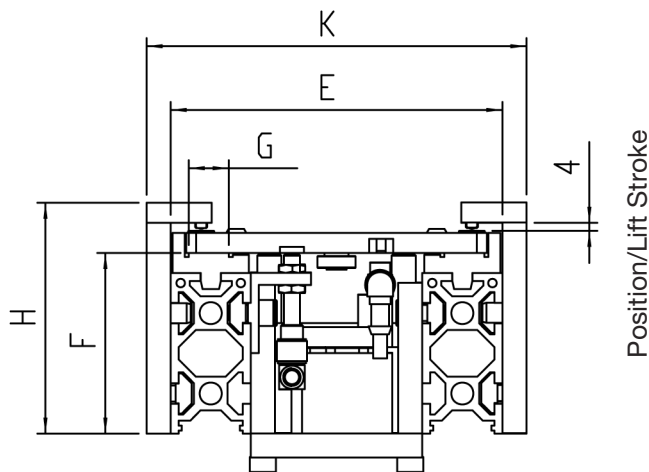
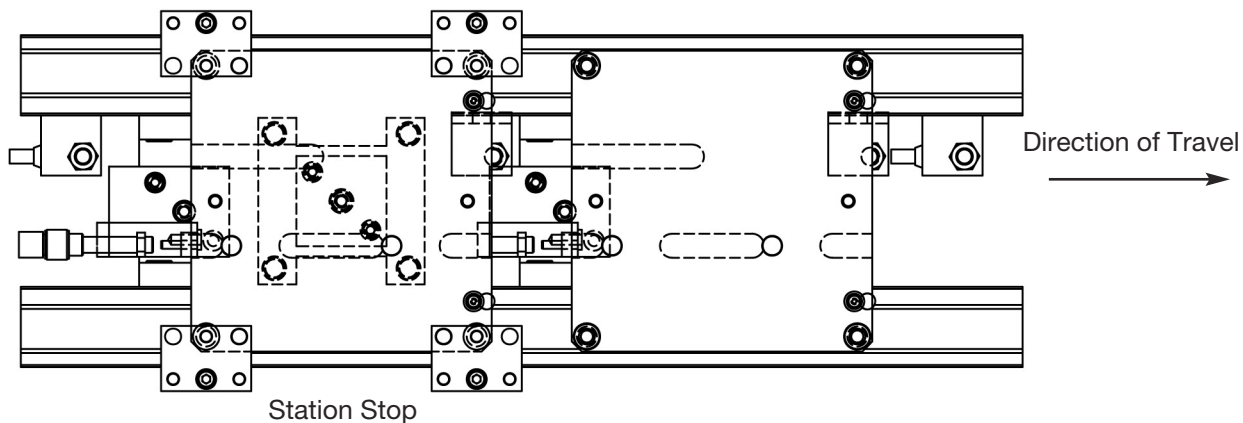

**NOTE:** Sensors (4 pieces) and cables are not included with the pallet system and need to be ordered separately.

**Sensor:** Order No. IR-008-NS-11L (NPN) or IR-008-PS-11L (PNP)

**Cable:** Order No. ST-11W-3B-U2X

Air Consumption per Stroke 0.4 NL  
3 Cyl. diameter 32 with 5mm stroke

Pallet Size AxB	E	F	G	H	K
150x100	111	60	14	80	135
150x150	165	90	20	115	189
200x150	165	90	20	115	189
200x200	215	90	20	115	239
250x200	215	90	20	115	239
250x250	265	90	20	115	289
300x200	215	90	20	115	239
300x300	315	90	20	115	339
400x300	315	90	20	115	339
400x400	415	90	20	115	439
500x400	415	90	20	115	439
500x500	515	90	20	115	539

**Order No.** for Positioning Automatic Station:

**MPA-020-xxx-xxx**

① = Pallet Length in mm  
② = Pallet Width in mm

## Positioning (Manual Workstation)

The pallets at the manual workstations are not accurately positioned as on the automatic workstations. They are individually centered with guides such that the position within approximately +/- 0.5mm can be maintained. The pallets are not lifted from the transport belt. Upon request automatic positioning can be added at any time.

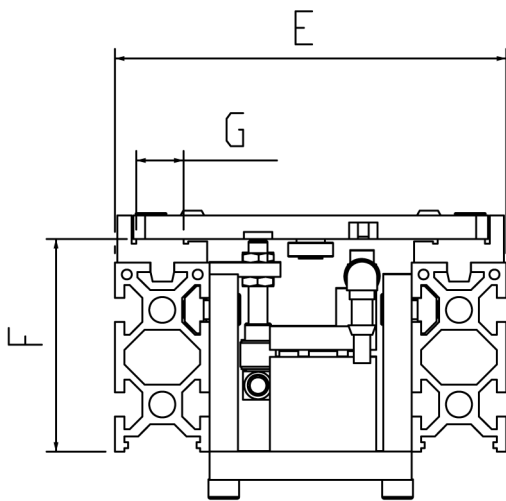
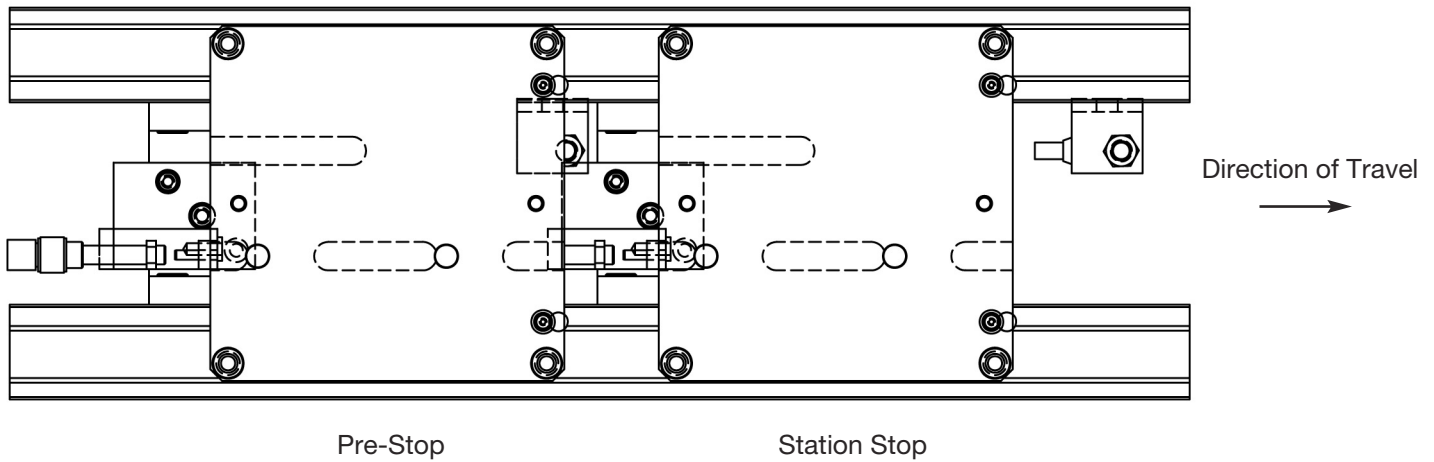
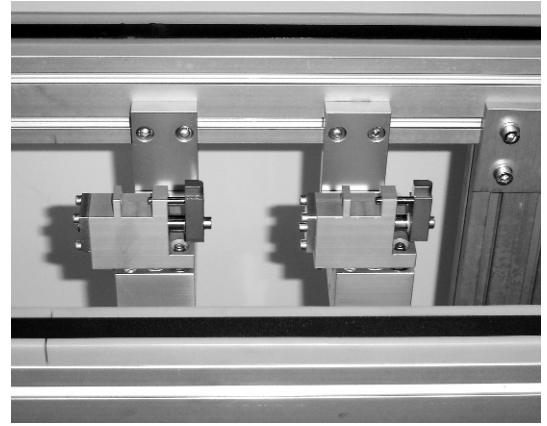

**NOTE:** Sensors (2 pcs.) and cables are not included with the MP System and must be ordered separately

**Sensor:**            **Order No.**        IR-008-NS-11L (NPN) or  
 IR-008-PS-11L

**Cable:**            **Order No.**        ST-11W-3B-U2X (2m)

Pallet Size AxB	E	F	G
150x100	111	60	14
150x150	165	90	20
200x150	165	90	20
200x200	215	90	20
250x200	215	90	20
250x250	265	90	20
300x200	215	90	20
300x300	315	90	20
400x300	315	90	20
400x400	415	90	20
500x400	415	90	20
500x500	515	90	20

**Order No.**            for Positioning Manual Workstation:        **MPA-025-<sup>①</sup>xxx-<sup>②</sup>xxx**

① = Pallet Length in mm  
 ② = Pallet Width in mm

## Partial Transport Track

- A partial transport track consists of 2 equal length transport belts and a common drive with rubber coated drive pulley. The belts of the transport tracks can be separately tightened and exchanged.
- The drive can be fixed at any place of the partial track.
- In addition to standard lengths of partial tracks, special lengths between 300mm and 5000mm are available.
- Several stations can be mounted on a partial track.

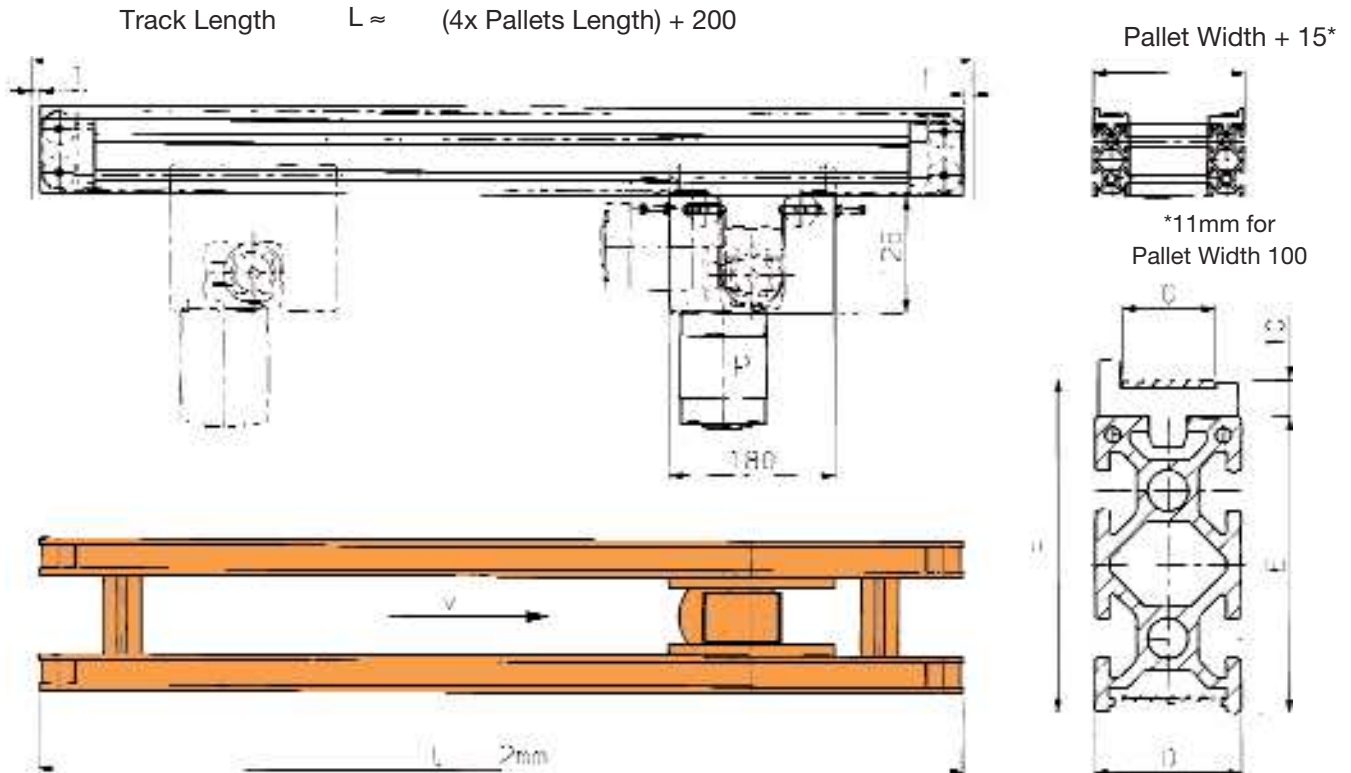

### Standard - Track Length

Pallet Length	Track Length	D	E	F	G	v* [mm/s]
100	1000	25	50	60	14	300
150	1000	40	80	90	20	300
200	1000	40	80	90	20	300
250	1200	40	80	90	20	300
300	1400	40	80	90	20	200
400	1800	40	80	90	20	200
500	2200	40	80	90	20	200

3 Phase AC Motor  
208

\* faster or slower transport speeds available (max.500mm/s, depending on transport weight)

Order No. for Partial Transport Track:

MPA-030-<sup>①</sup>xxx-<sup>②</sup>xxx

① = Pallet Length in mm  
② = Pallet Width in mm

## Connecting Transport Tracks

- Each connecting transport track consists of two transport belts of different lengths and one common drive as similar to the partial transport track.
- Two each connecting tracks are identical.
- Special lengths up to 5000 mm are available.
- Small single purpose systems can be constructed using only one drive. See example 2 on page 10.002.
- Automatic stations and manual stations can be integrated into the connecting transport tracks

### Standard Dimension:

Pallet Length	L
100	1000
150	1000
200	1000
250	1200
300	1400
400	1800
500	2200

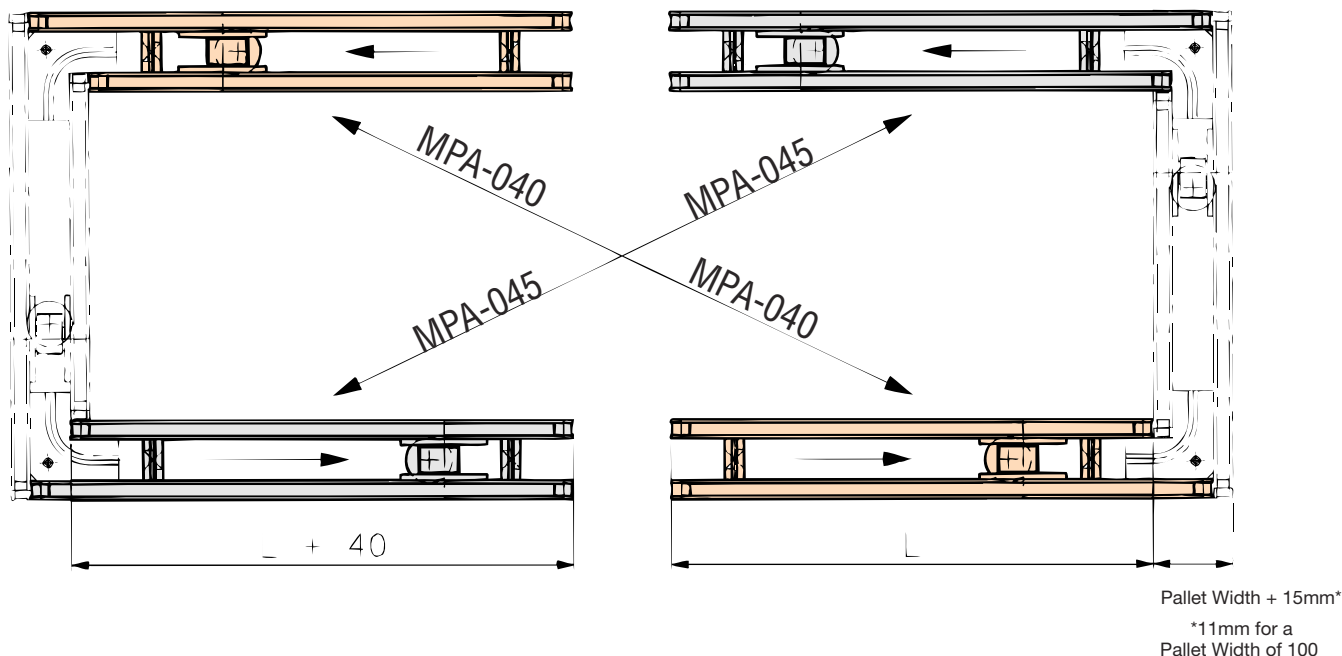
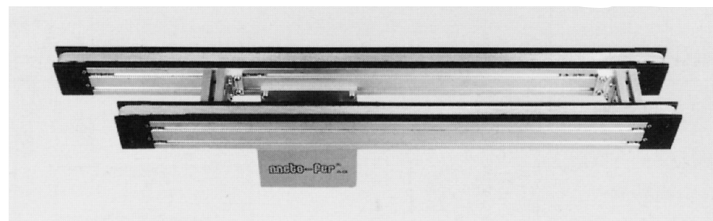

Order No. for One Connecting Transport Track:

MPA-040-<sup>①</sup>xxx-<sup>②</sup>xxx  
 MPA-045-<sup>①</sup>xxx-<sup>②</sup>xxx  
 ① = Pallet Length in mm  
 ② = Pallet Width in mm

## End Module

- Each turn-around consists of two transport belts of different lengths and a common drive as on the partial transport track.
- The turn-around to the left and right are identical.
- Each turn-around contains tow angles with guiding track and support transfers for the transport pallets.
- The End Modules are directly assembled to the connecting transport tracks.
- Automatic Stations and manual stations can be integrated into the end modules. (Dimension D; Change)

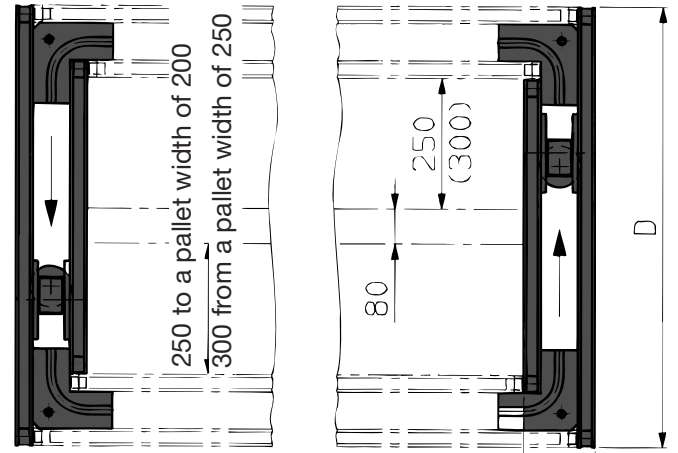
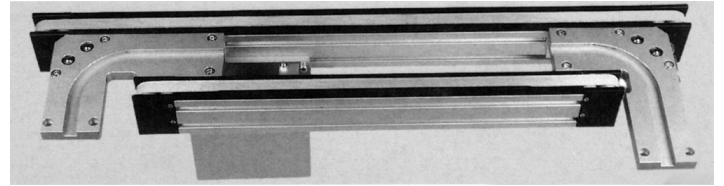

Pallet Width + 15mm\*

\*11mm for a pallet width of 100

### Standard Dimensions:

Pallet Width B	D
100	810
150	910
200	1010
250	1210
300	1310
400	1510
500	1710

Order No. for End Module:

MPA-050-<sup>①</sup>xxx-<sup>②</sup>xxx

- ① = Pallet Length in mm  
② = Pallet Width in mm

## End Module Vertical

A = Pallet Length  
B = Pallet Width

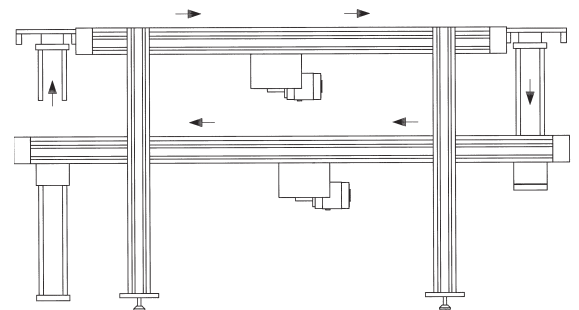
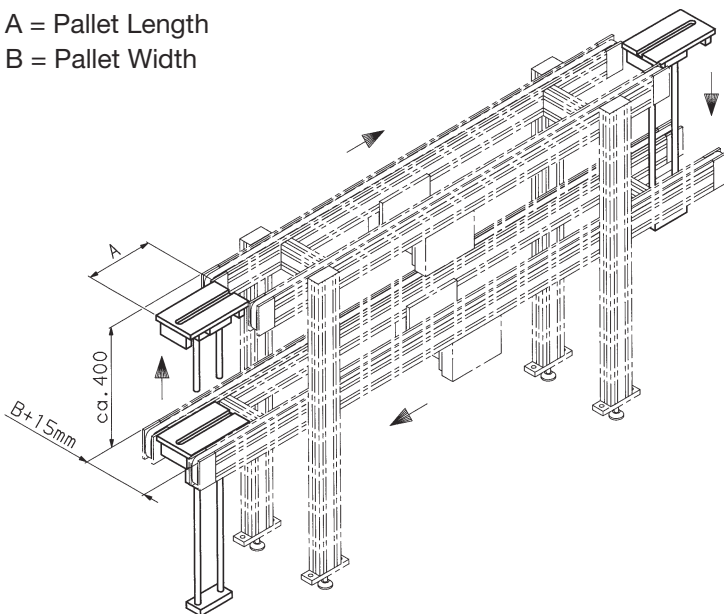

Order No. for End Module Vertical:

MPA-051-<sup>①</sup>xxx-<sup>②</sup>xxx

- ① = Pallet Length in mm  
② = Pallet Width in mm



## Manual Workstation “A”

### “In Line”

- This workstation is “in line” assembled and fulfills all ergonomic and economical requirements.
- The transport track is mounted on a stand which is directly integrated into the assembly line.
- The arm- and feet rests are adjustable. The feet rest is coated with a slip resistant, black rubber.
- The pallets can be positioned with either manual or automatic workstations (Sheet 10.004).
- The throughput of the system can be influenced with this workstation. The working content should not exceed the throughput of the slowest automatic station.

**Order No.** for Manual Workstation A:  
(without positioning)

① ②  
**MPA-060-xxx-xxx**

**Order No.** Automatic Workstation Positioning  
(Sheet 10.004)

① ②  
**MPA-020-xxx-xxx**

**Order No.** Manual Workstation Positioning  
(Sheet 10.004)

① ②  
**MPA-025-xxx-xxx**

- ① = Pallet Length in mm  
② = Pallet Width in mm

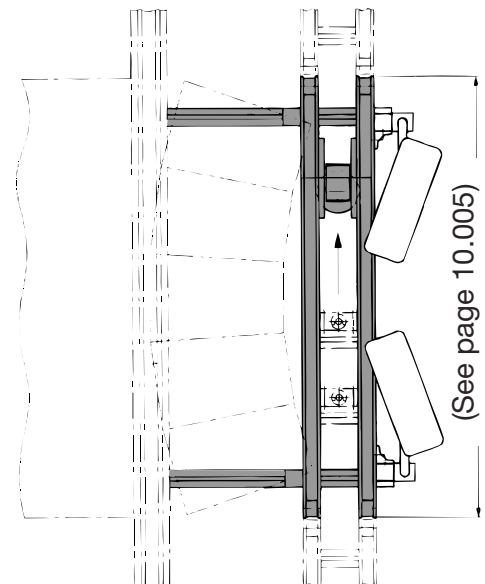
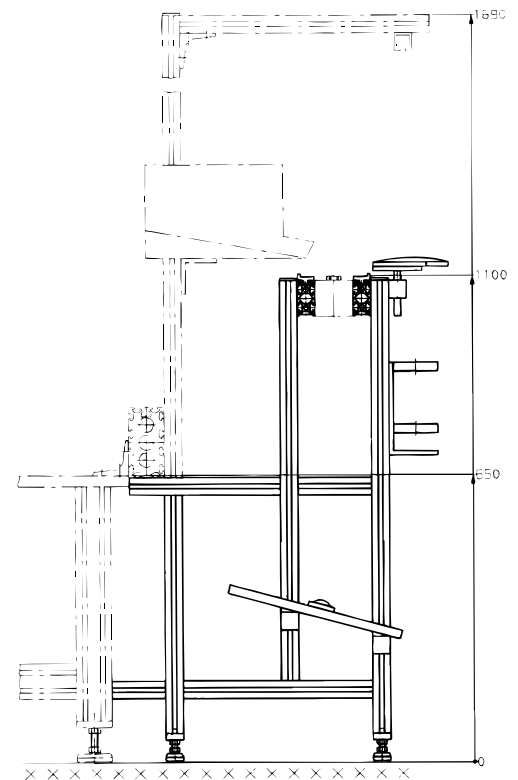

# Manual Workstation "B"

"PARALLEL EXIT"

- Ideal for repair or random check working place, or if several working places in sequence are needed.
- This requirement does not influence the throughput directly.
- Random checks/tests also can be executed with Automatic Stations. Air consumption per positioning 0.26 ml, 2 cylinders diameter 12mm with 15mm stroke

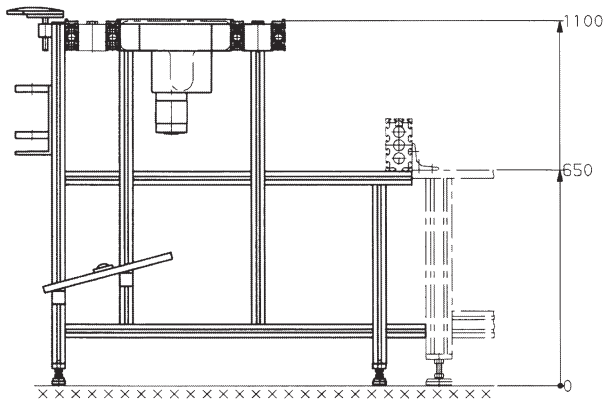
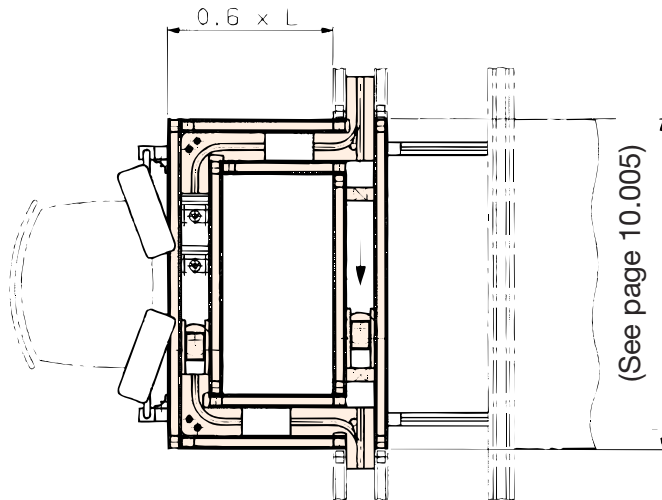

**Order No.** for Manual Workstation "B":  
(without positioning)

① ②  
**MPA-070-xxx-xxx**

**Order No.** Automatic Workstation Positioning  
(Sheet 10.004)

① ②  
**MPA-020-xxx-xxx**

**Order No.** Manual Workstation Positioning  
(Sheet 10.004)

① ②  
**MPA-025-xxx-xxx**

① = Pallet Length in mm  
② = Pallet Width in mm

# Manual Workstation "C"

## "PERPENDICULAR EXIT"

- This kind of exit can be used by manual as well as by automatic workstations.
- Length A and width B basically can be configured of any size, whereby the minimum dimension for  $B = 2 \times (\text{Pallet width} + 15) + 120\text{mm}$ .
- Standard dimensions for A = 1500 or 2000 mm.

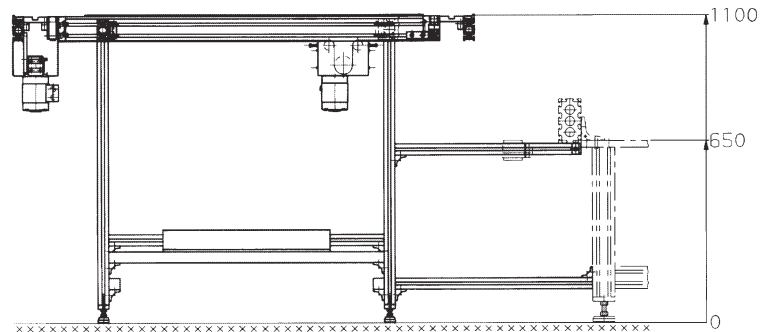
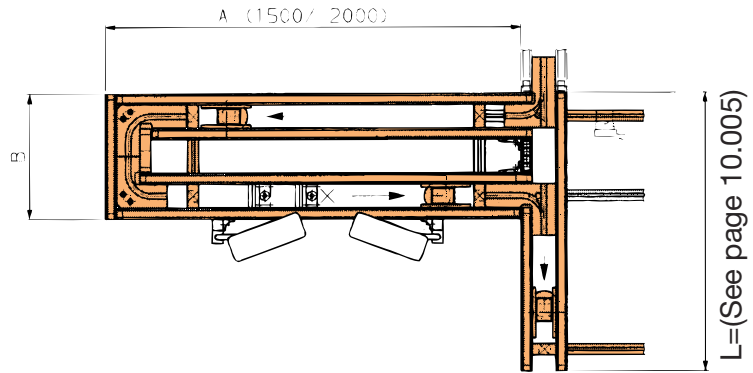
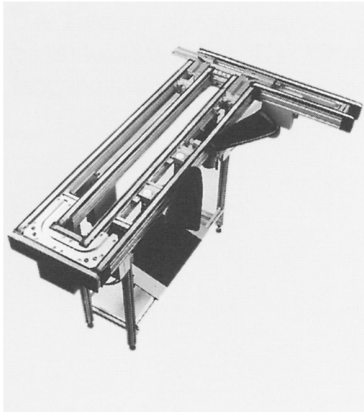

**Order No.** for Manual Workstation "C":  
(without Positioning)

MPA-080-<sup>①</sup>xxx-<sup>②</sup>xxx

**Order No.** Automatic Workstation Positioning  
(Sheet 10.004)

MPA-020-<sup>①</sup>xxx-<sup>②</sup>xxx

Air consumption per positioning  
0.26 ml, 2 Cyl. diameter 12mm with  
15mm stroke

Pallet Length	A	B
100 - 300	1500	See Text
300 - 500	2000	See Text

**Order No.** Manual Workstation Positioning  
(Sheet 10.004)

MPA-025-<sup>①</sup>xxx-<sup>②</sup>xxx

- ① = Pallet Length in mm
- ② = Pallet Width in mm

## Base Table

- The table top of the Base Table consists of a 25mm thick ground and zinc plated steel plate.
- The lower frame consists of MFP-080-080 profiles and is screw assembled.
- Two angled brackets on the rear of the plate are for the mounting and positioning of a pneumatic channel profile.

### Standard Dimension:

Pallet width	F	G	H
150 - 200	250	900	992
250 - 300	300	1050	1000
350 - 400	300	1150	1000
450 - 500	300	1300	1100

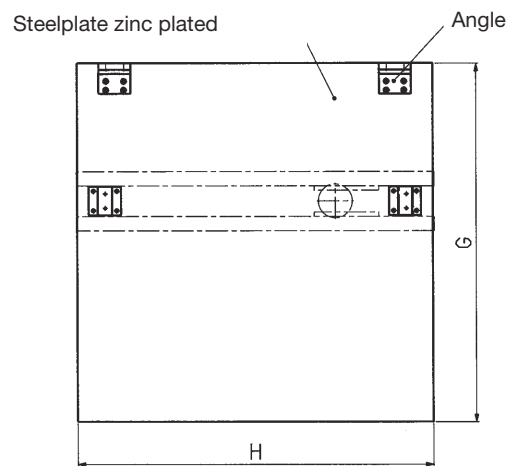

\* 11mm by a pallet width of 100

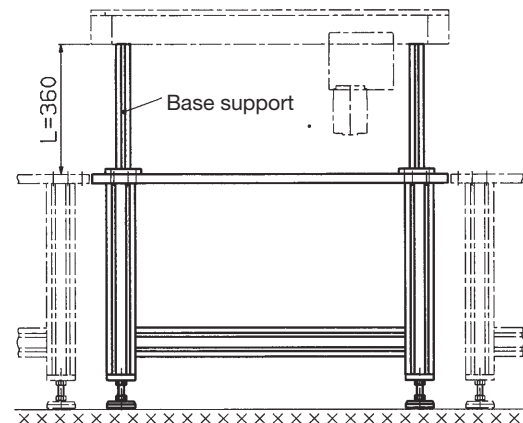
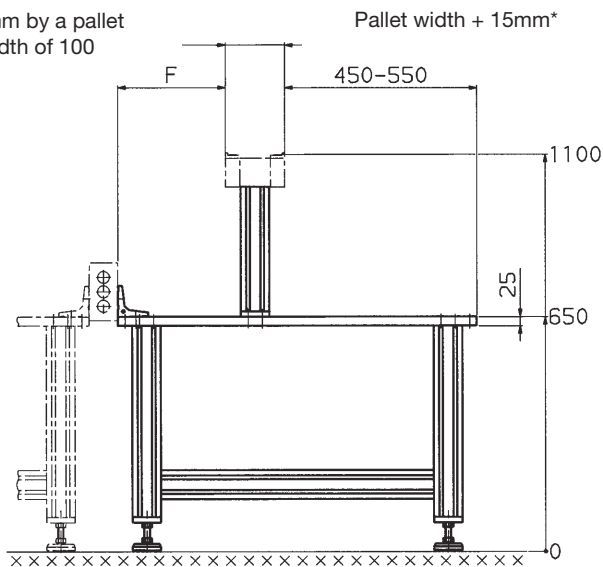

**Order No.** For Base Table with Stand:  
 For Base Table without Stand:  
 For Base Table without Steel plate,  
 with Stand:  
 For a Stand:

① ②  
**MPA-090-xxx-xxx**  
**MPA-091-xxx-xxx** ① = Pallet Length in mm  
 ② = Pallet Width in mm  
**MPA-092-xxx-xxx**  
**MPA-093-\_\_\_\_\_** — Length in mm (standard 360 mm)

## Stand

- The stands are used as support of the tracks.
- After assembly the stands can be anchored to the floor.
- The stands can be adjusted in height +/- 15mm  
Standard 945mm, top of belt

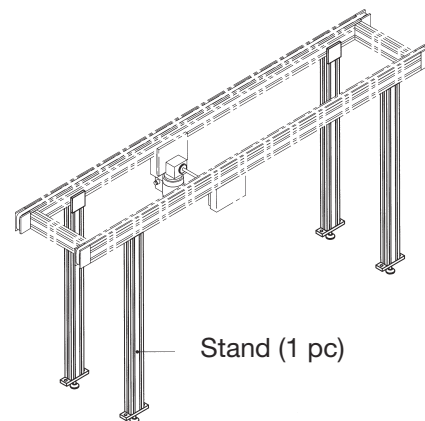
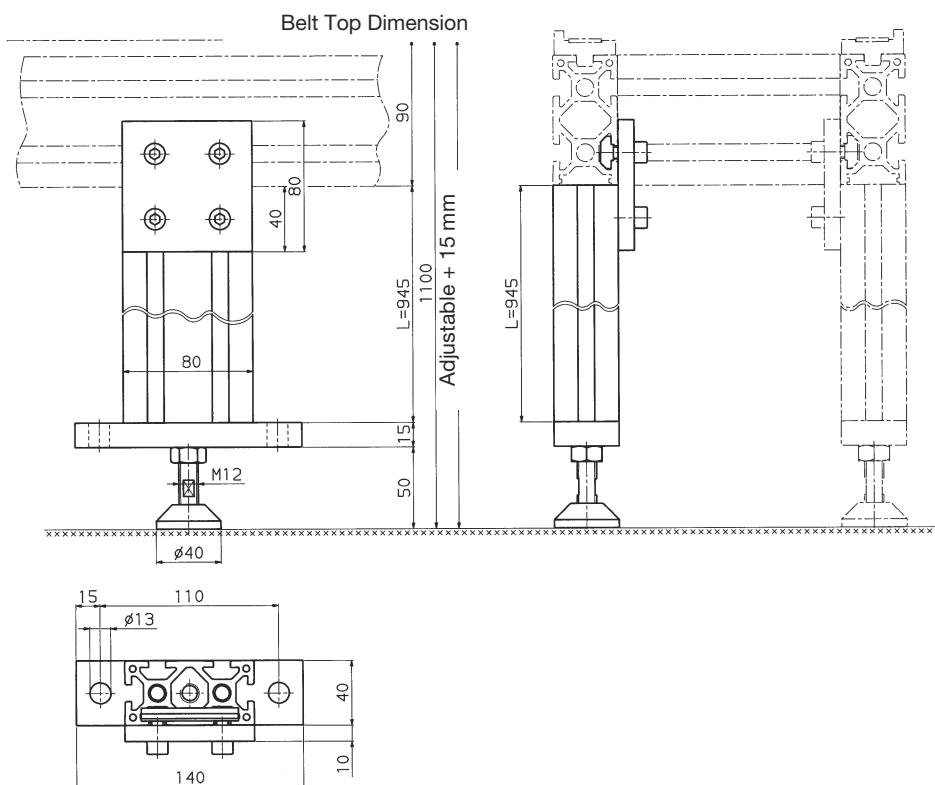

Example of Track with 4 Stands

Order No. For Stand:

MPA-110-

Length in mm (Standard 945 mm)

## Example of Pallet Transfer System OVER / UNDER (with Elevators)

Meto-Fer Automation's modular, non-synchronous Pallet Transfer Systems incorporate a dual belt conveyor with manual or fully automatic assembly stations.

Pallets, which contain the work piece, travel from assembly station to station, pallets can accumulate in front of every work place for maximum efficiency and system flexibility. Our elevators specifically designed for over / under systems, reduce your lines overall floor space requirements, and any elevator stroke is possible.

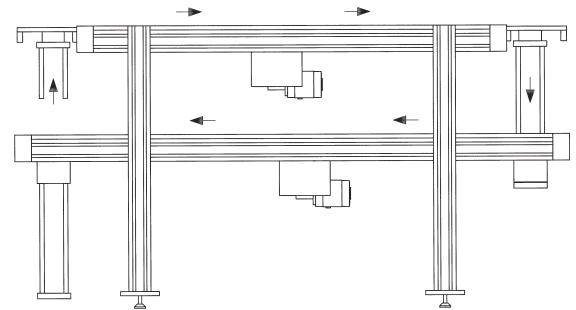
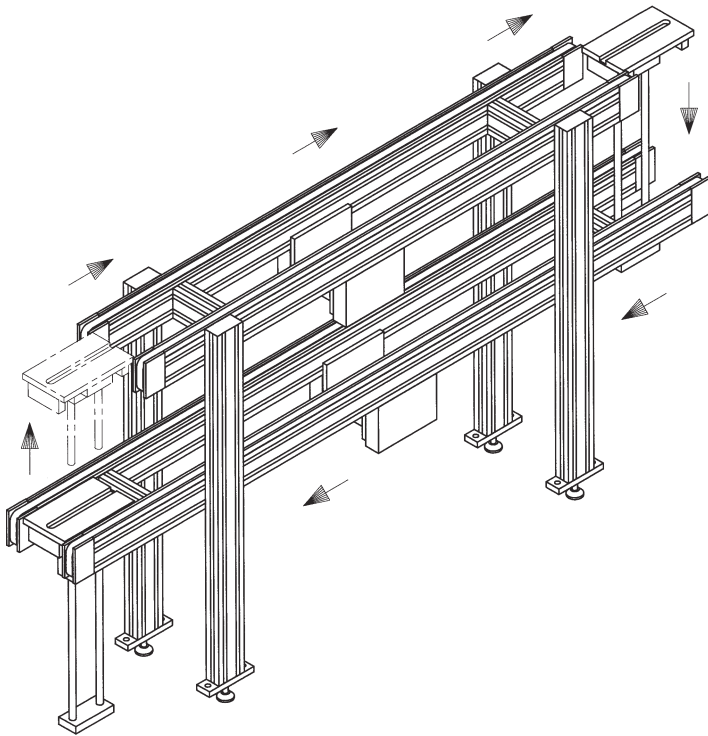

**Order No.**

Elevator

MPA-051-<sup>①</sup>xxx-<sup>②</sup>xxx

(Additional information for price: stroke length, cycle time and pallet load)

① = Pallet Length in mm  
② = Pallet Width in mm

# Large Pallet System GP (Over-Under System)

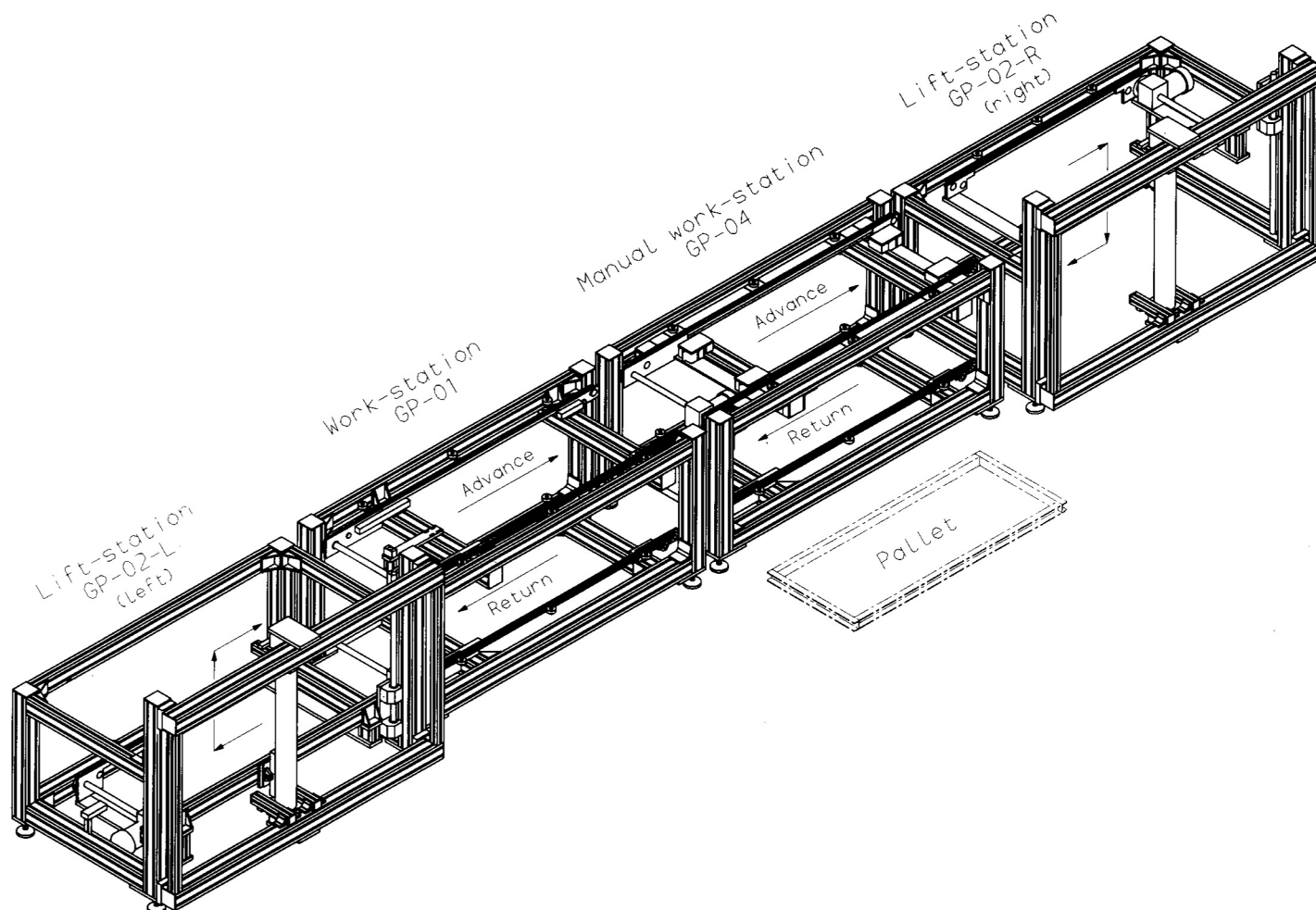

## Design and Function:

- The GP-System consists of 3 exchangeable elements:
  - GP-01 Work Station
  - GP-02 Lift Station
  - GP-04 Manual Work Station
- Length of the linear transport system: as required
- Linear travel by a two-belt-system

## Technical data:

- Size of pallets (area)
 

min.	400 x 1000 mm	
max.	1000 x 2000 mm	
- velocity, standard conveyor belt
 

	36 m/min	
--	----------	--
- Max. pallet load
 

	80 kg	(176 lb)
--	-------	----------
- Positioning accuracy (on work station GP-02)
 

	+/- 0.2 mm	
--	------------	--
- Height of transport belt from floor (standard)
 

	900 mm	
--	--------	--

(This height can be adapted to the customers requirements)

# Large Pallet System GP

## Work Station GP-01

At this station, the pallets are singled out (with initiators and pneumatic cylinders) and indexed into the work station.  
The maximum force of pressure of one station is 1000 N.

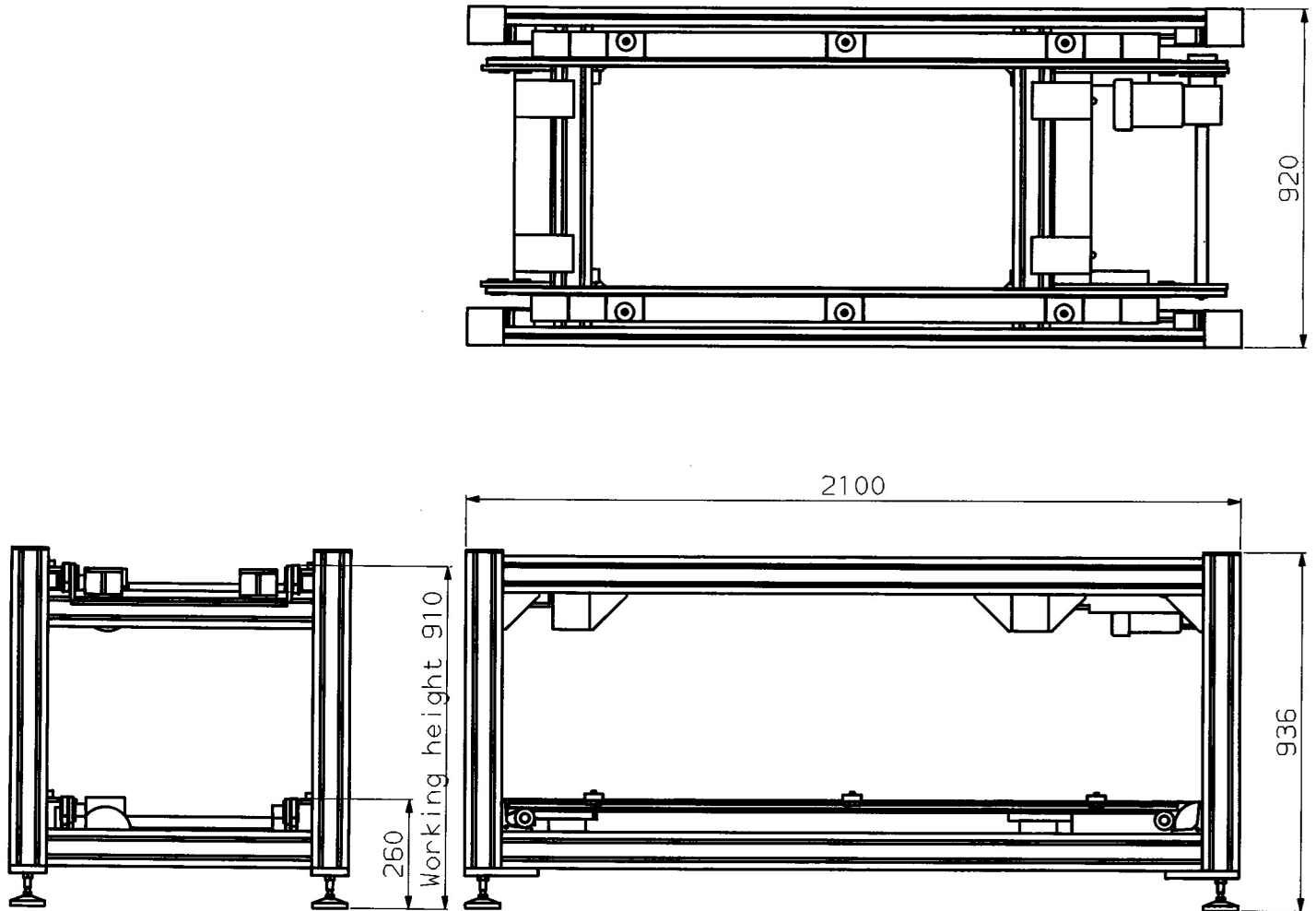

**Order No.** GP-01

### Technical data:

- Operating medium
- Operating pressure
- Air connections
- Positioning accuracy
- Electrical connection

Compressed air  
43.5 - 116 psi (3-8 bar)  
R1/4"

+/- 0.2 mm

Please specify on order: Voltage, Number of phases, and Frequency  
(Standard: 3 phase / 208 / 50 Hz)