

Горизонтальный редуктор с электродвигателем

Code -11/

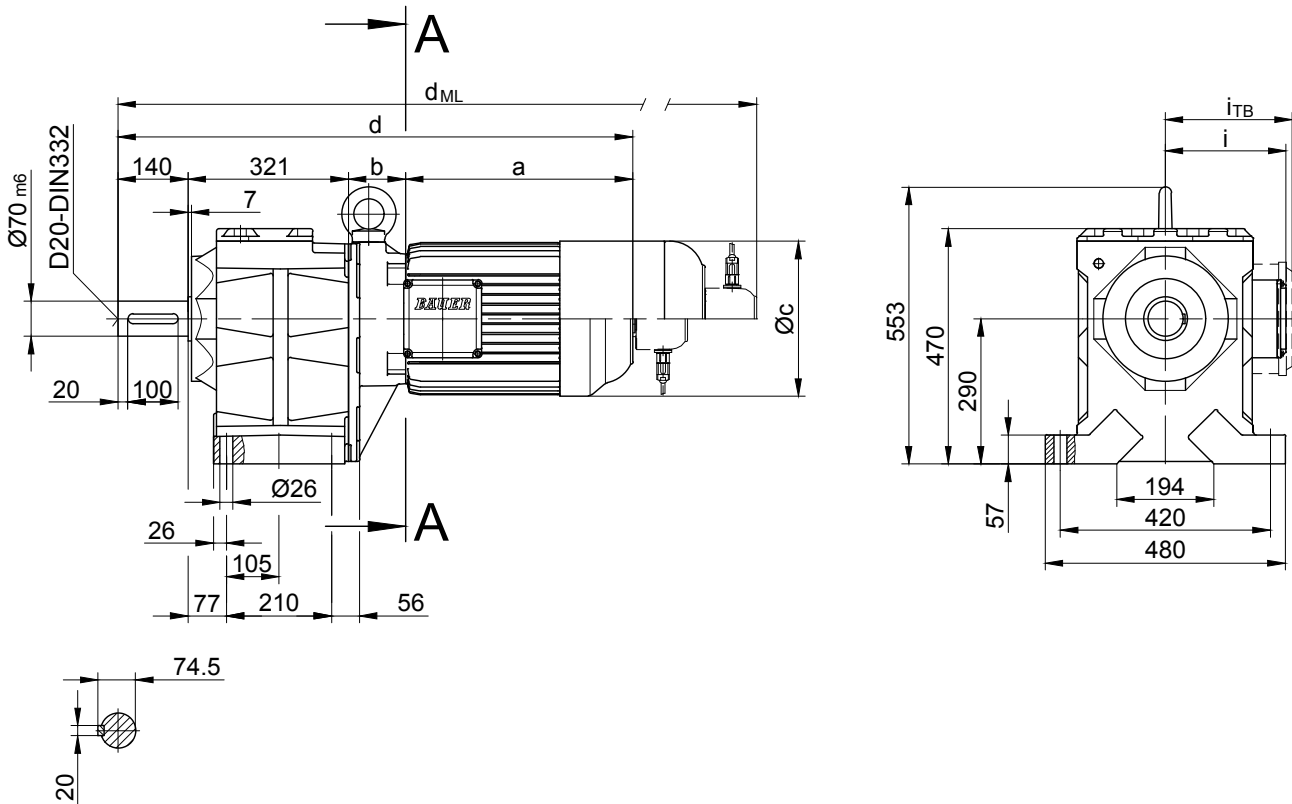

Размеры в мм

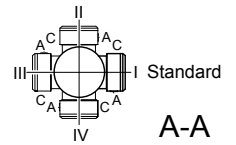

BG80(Z)	k	l	m	n	o	q	s	t	D ₇	D _{ML7}
Standard -37/	400	350	300	20	4 x 17.5	345	5	140	d+24	d _{ML} +24
Standard -27/27/	350	300	250	20	4 x 17.5	345	5	140	d+24	d _{ML} +24
Standard -74/74/	450	400	350	22	8 x 17.5	355	5	130	d+24	d _{ML} +24

Type	a	b	c	d	i	Варианты исполнений с навесными Ejector and clutch devices устройствами двигателя				
						i _{TB}	ES../ZS..	G	ES../ZS..-G	RR/RL
							d _{ML}	d _{ML}	d _{ML}	d _{ML}
BG80Z-../D..09..	251	252.5	181	964.5	124	158	1057.5	1071.5	1162	1057.5
BG80-../D..11..	319	87	228	867	181	181	965	974	1069.5	965
BG80Z-../D..11..	319	259	228	1039	181	181	1137	1146	1241.5	1137
BG80-../D..13..	393	100	258	954	218	218	1065	1061	1169.5	1065
BG80Z-../D..13..	393	272	258	1126	218	218	1237	1233	1341.5	1237
BG80-../D..16..	454.5	114	310	1029.5	244	244	1173	1136.5	1277	1173
BG80Z-../D..16..	454.5	286	310	1201.5	244	244	1345	1308.5	1449	1345
BG80-../D..18..	542	136	348	1139	288	288	1288.5	1246	1392.5	1288.5
BG80Z-../D..18..	542	308	348	1311	288	288	1460.5	1418	1564.5	1460.5
BG80-../D..20L	643.5	153	363	1257.5	303.5	303.5	1385	1363.5	1491	1385
BG80-../D..22S	703.5	153	363	1317.5	303.5	303.5	1445	1423.5	1551	1445
BG80-../D..22M	703.5	153	363	1317.5	303.5	303.5	1445	1423.5	1551	1445

