

**DOBIKON 1015.0**  
*Installation Manual*

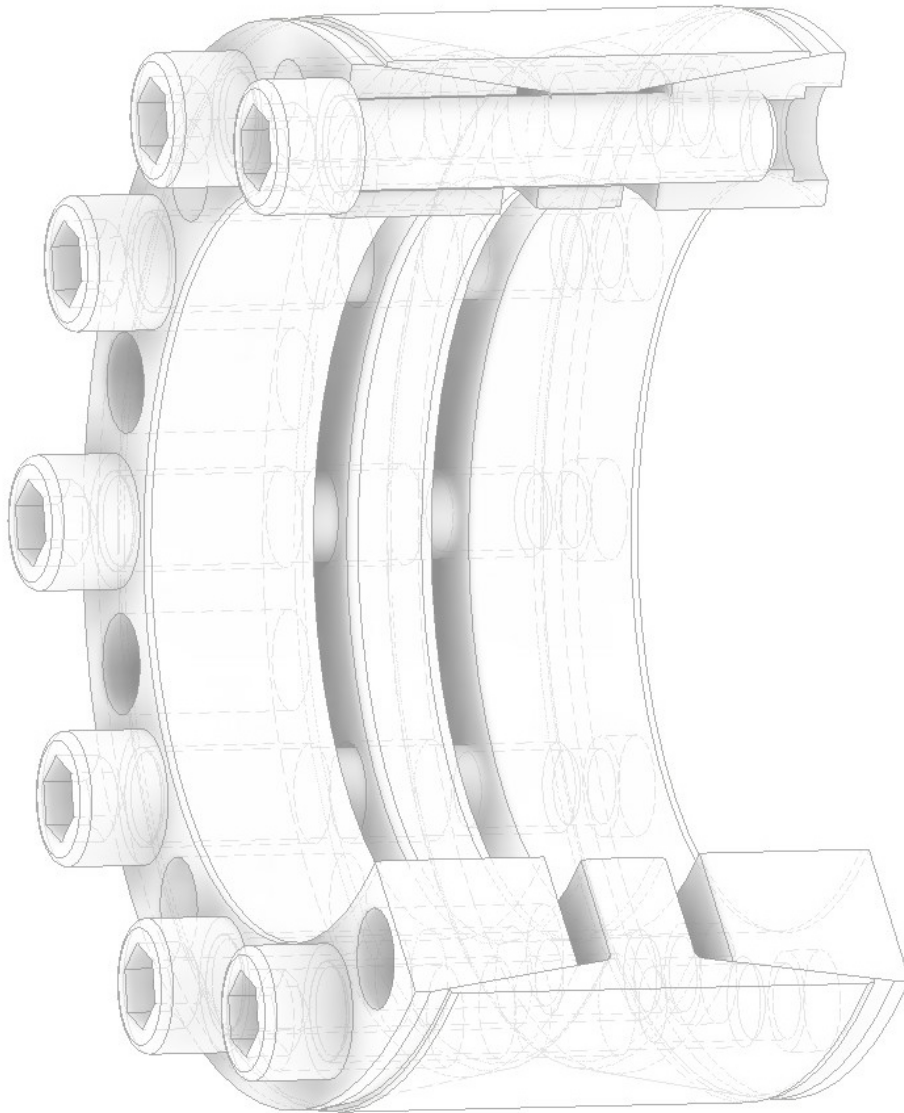

Only available from BIKON-Technik GmbH • 41468 Neuss • Germany

A Development of BIKON-Technik GmbH - introduction on global market in year 1974

## Index:

We reserve all rights with regard to this technical data and its content. Without our prior written approval it is not allowed to duplicate this technical data or parts of it, nor to grant access to it by third parties or to exploit it otherwise (including extracts) without authority.

All topics and specification dealt with are only valid for original „BIKON“ or „DOBIKON“ products.

We will not accept any liability for damages arising from misinterpretation, application or constructional flaws (regarding equipment wherein our products shall be installed). All information is based upon our knowledge of the current state of the art at the draft date of this technical data.

We refer to our trademark and further intellectual property rights as well as our conditions of sale that shall apply.

April 2023



**BIKON-Technik GmbH**

Hansemannstrasse 11 · 41468 Neuss · Germany  
Tel. ++49 (0) 2131-71889-0 · [www.bikon.de](http://www.bikon.de) · E-Mail: [info@bikon.de](mailto:info@bikon.de)

# DOBIKON 1015.0

Schematic sketch

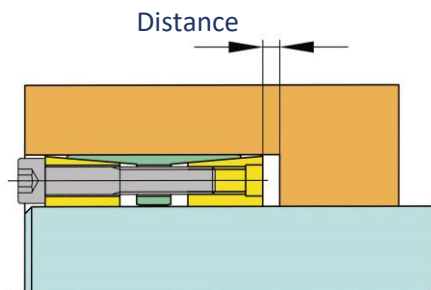

## Space - generally

By use of stepped bores the locking assembly should never be pushed to block against the hub. There must be let distance about 2 – 5 mm to the hub to be able to remove the rings from each other. This applies to all BIKON locking assemblies.

## Shafts with keyways

DOBIKON Locking assemblies can be tighten over keyways (according to DIN) on shafts. The function of the locking assembly is not affected.

**Keyways in the hub are not allowed !**

## Space - DOBIKON 1015.0

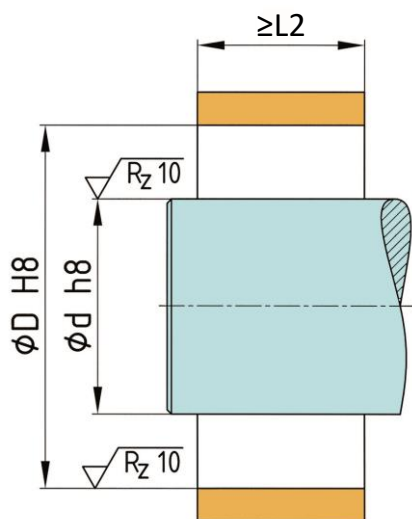

d	D	L2	d	D	L2	d	D	L2
mm	mm	mm	mm	mm	mm	mm	mm	mm
25	55	36	95	135	60	300	375	114
28	55	36	100	145	70	320	405	137
30	55	36	110	155	70	340	425	137
35	65	42	120	165	70	360	455	161
40	70	42	130	180	79	380	475	161
45	75	42	140	190	79	400	495	161
48	85	50	150	200	79	420	515	161
50	85	50	160	210	79	440	535	161
55	90	50	170	225	92	460	555	161
60	95	50	180	235	92	480	575	161
65	100	50	190	250	104	500	595	161
70	110	60	200	260	104	520	615	161
75	115	60	220	285	110	540	635	161
80	120	60	240	305	110	560	655	161
85	125	60	260	325	110	580	675	161
90	130	60	280	355	114	600	695	161

## TA – Tightening torque of screws

d	M	TA	d	M	TA	d	M	TA	d	M	TA
mm	-	Nm	mm	-	Nm	mm	-	Nm	mm	-	Nm
25	M6	17	75	M10	83	170	M14	230	380	M22	930
28	M6	17	80	M10	83	180	M14	230	400	M22	930
30	M6	17	85	M10	83	190	M14	230	420	M22	930
35	M6	17	90	M10	83	200	M14	230	440	M22	930
40	M6	17	95	M10	83	220	M16	355	460	M22	930
45	M6	17	100	M12	145	240	M16	355	480	M22	930
48	M8	41	110	M12	145	260	M16	355	500	M22	930
50	M8	41	120	M12	145	280	M20	690	520	M22	930
55	M8	41	130	M12	145	300	M20	690	540	M22	930
60	M8	41	140	M12	145	320	M20	690	560	M22	930
65	M8	41	150	M12	145	340	M20	690	580	M22	930
70	M10	83	160	M12	145	360	M22	930	600	M22	930

## Installation

### 1.

DOBIKON locking assemblies are delivered ready for installation and oiled. The screws have been unscrewed a few threads.

Make sure that the rings fit loosely on top of each other (self-locking cone).

If the locking assembly is to be dismantled into its individual parts, please mark the position of the rings in relation to each other!

The slits are offset and not aligned, nor should they be aligned with each other.

From  $d = 180$  mm the outer rings are not slitted.

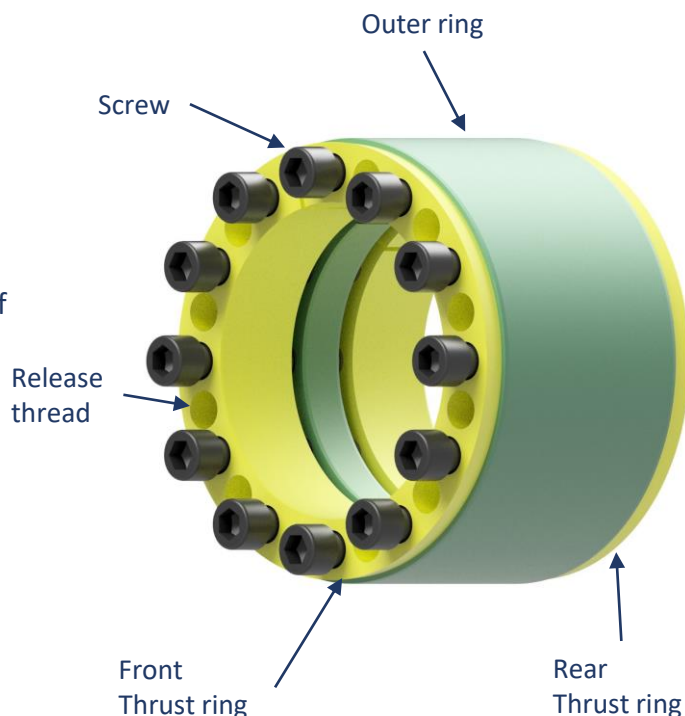

### 2.

Oil the shaft and hub and push the locking assembly into the installation space.

**Do not use molybdenum disulfide (MoS<sub>2</sub>), assembly paste or grease!**

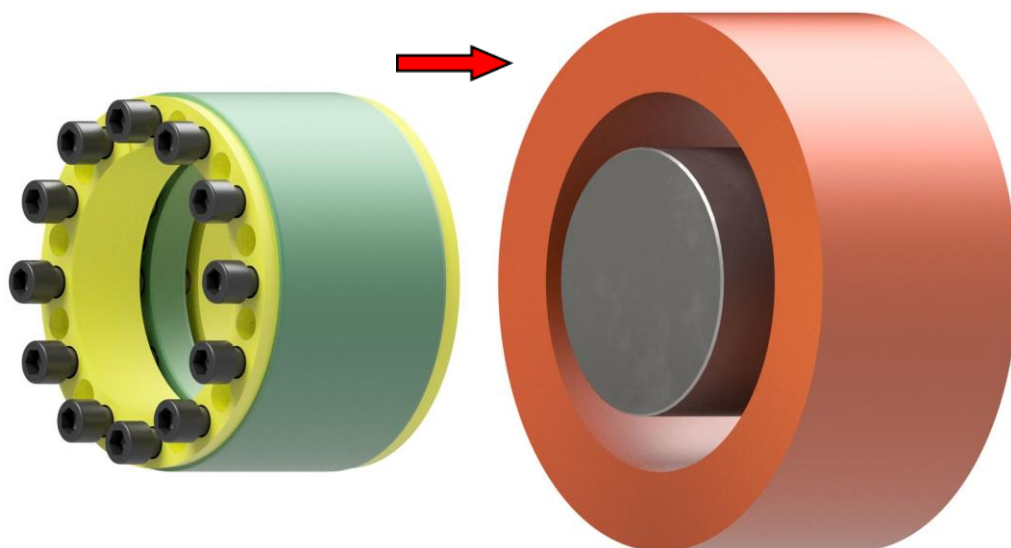

## Installation

### 3.

The locking assembly must sit flush with the hub.

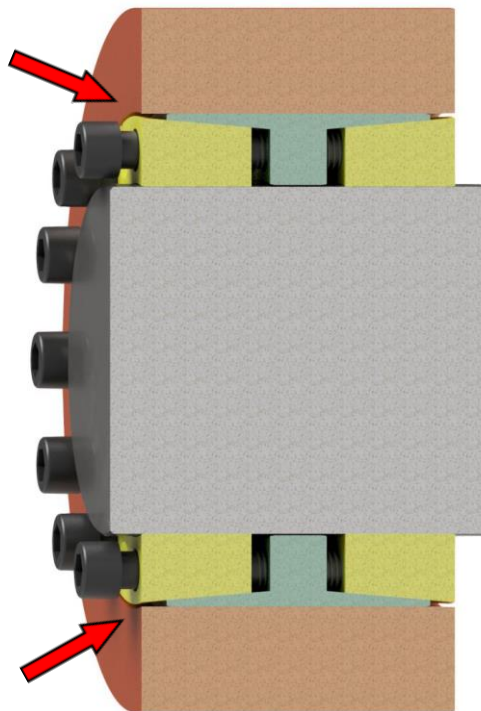

### 4.

Tighten the screws evenly crosswise and in several stages using a torque wrench.

#### control !

The tightening of the screws and the assembly is complete when no more screws can be tightened with the 100% tightening torque.

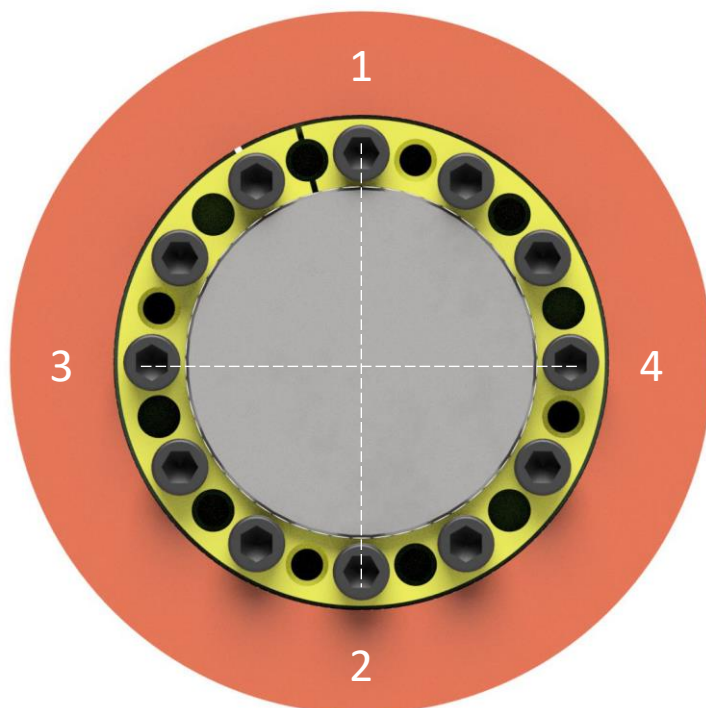

## Installation

5.

By tightening the screws, the thrust rings slides and tightens the connection. The cone is self-locking and will not loosen by itself if the screws are loosened if it is operated properly.

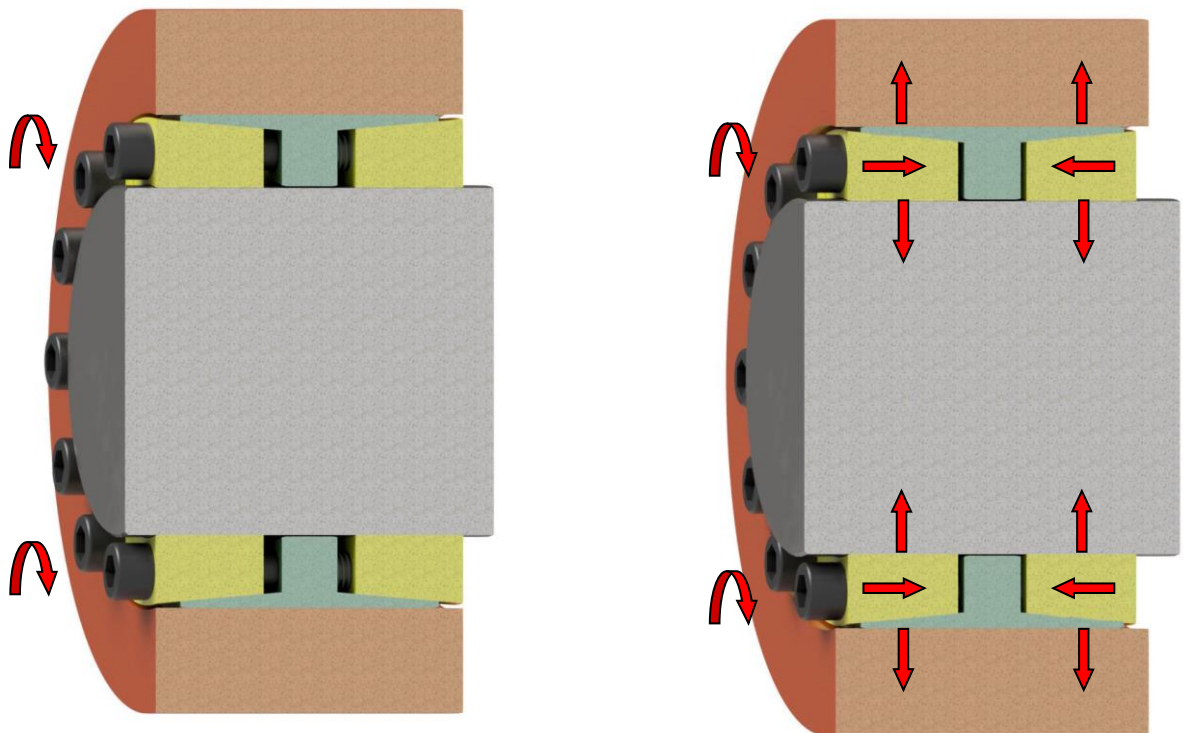

The locking assembly is maintenance-free and the screws do not have to be tightened after a certain period of operation.



## Removal

### 1.

Loosen all screws and unscrew all screws as there are release threads.

As a rule, the number of screws corresponds to the number of release threads in the front and rear thrust ring.

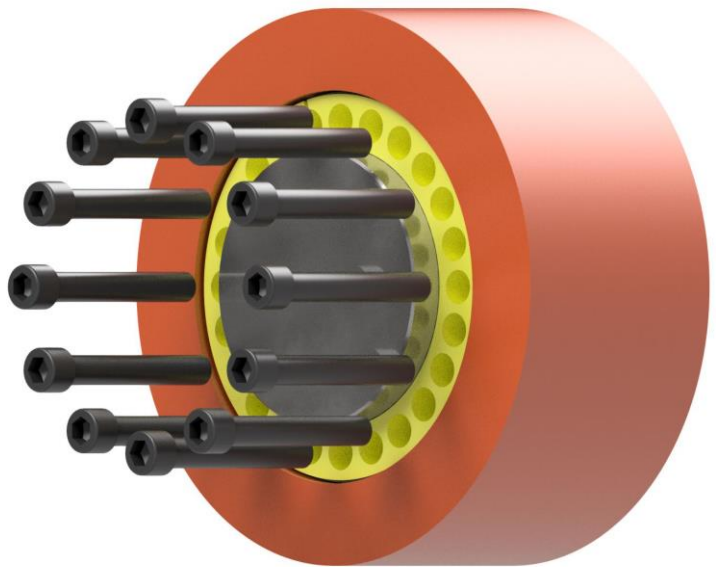

### 2.

Oil the screws and screw them into the release threads of front and rear thrust ring and tighten them **all** crosswise with a torque wrench until the thrust rings slide off the shaft and outer ring.

#### **Important !**

The shaft must be clean and free of particles. The thrust rings slide on the shaft when loosened.

(Grind the release screws flat on the face side before screwing them in)

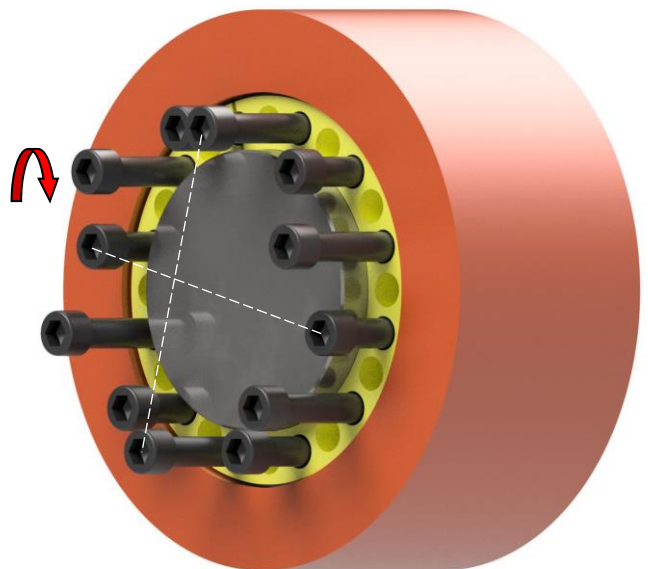

## Removal

3.  
The thrust rings slide on the shaft and outer ring and release the connection.

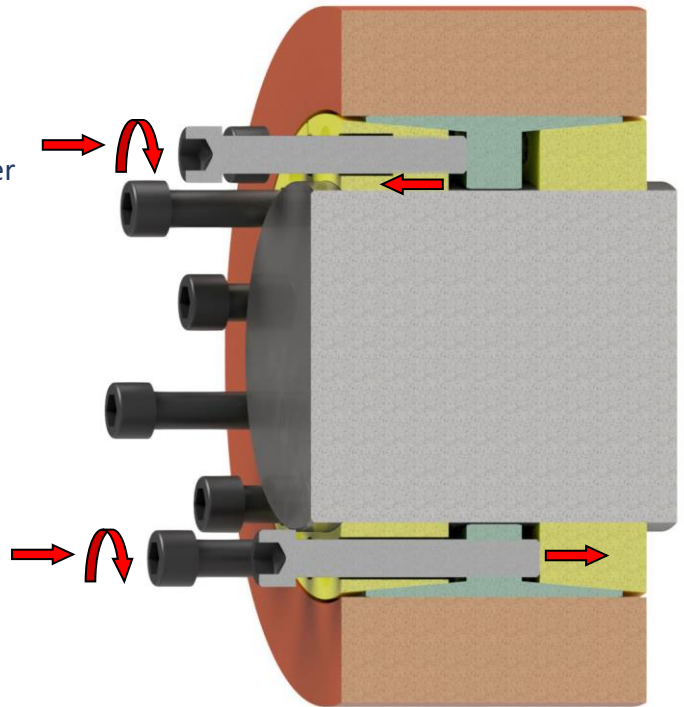

4.  
Remove the locking assembly from the space.

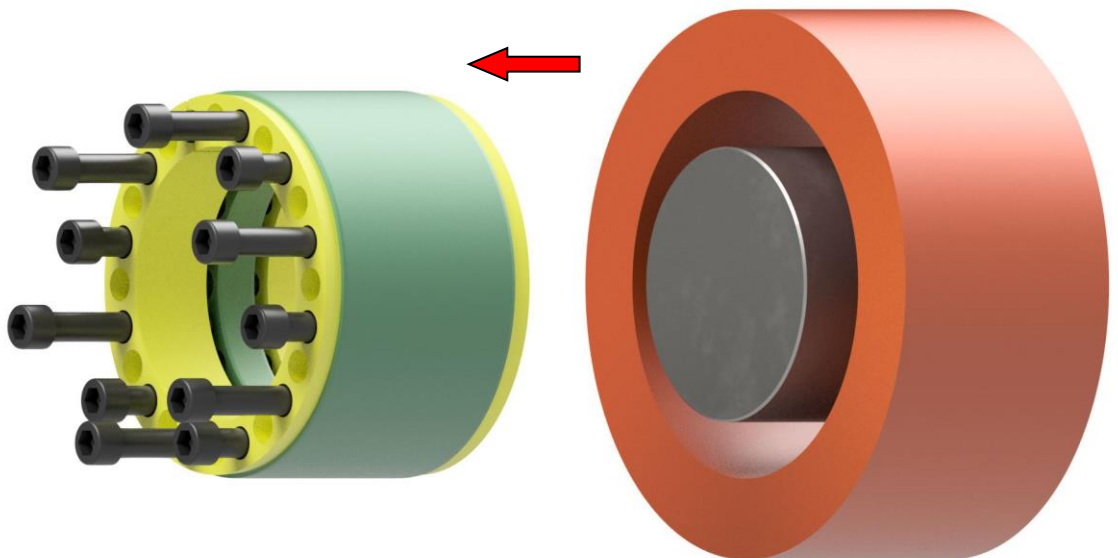

### Reusability

Undamaged locking assemblies can be reused.

**The screws must be changed after each use!**



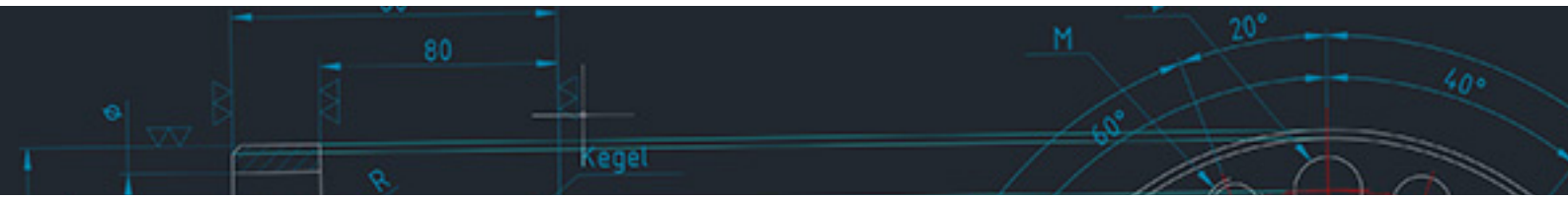

# BIKON-Technik GmbH

Hansemannstrasse 11

41468 Neuss • Germany

Tel. ++49 (0) 2131-71889-0

[www.bikon.de](http://www.bikon.de)

E-Mail [info@bikon.de](mailto:info@bikon.de)