

# Sensors & Instruments Product Guide



RTDs | Thermocouples | Thermistors | Humidity | Assemblies | Transmitters | Monitors | Controllers

# Minco: Providing Temperature Sensing Solutions for Demanding Applications

For nearly 60 years, Minco has been designing and manufacturing advanced products for some of the world's most demanding applications. Our offering includes temperature sensing and control solutions, thermal heating solutions, flex circuit solutions, and integrated products—coupled with broad assembly capabilities.

## Sensors



## Instruments



## Flexible Thermofoil™ Heaters



## Flex Circuits



Minco's products are supported by expert engineering services to help customers plan and integrate Minco components into their products, delivering proven quality and performance in thousands of applications worldwide.

## Superior temperature sensing solutions

Minco works diligently to provide the best temperature sensing and instrumentation solutions for your application. We have hundreds of off-the-shelf solutions to meet your immediate requirements, and have designed thousands of custom sensing packages to seamlessly operate in a wide range of applications.



Minco builds sensors from start to finish ensuring exceptional product quality. As a company, we strive for cost-effective solutions through efficient design and easy installation. This allows you to save time and money without sacrificing accuracy and reliability.



## Minco today: global and growing

Minco's engineering and manufacturing facilities employ over 600 people worldwide. More than 300,000 ft<sup>2</sup> (27,900 m<sup>2</sup>) of manufacturing space provides the capacity and infrastructure to support a variety of applications for global customers in diverse markets.

Minco's seamless operational capabilities allow us to design and manufacture integrated components from prototype to production, which simplifies the supply chain and improves our response time.



Minco is ISO 9001:2008 / AS9100:2009 (Rev.C)/EN9100 / SJAC9100 (Registrar: TÜV) certified and we have the capabilities to meet many other quality assurance, process, and product specifications per your requirements.

## Minco Fast Facts

**Founded:** 1956

**Organization:** Privately held

**Headquarters:** Minneapolis, Minnesota, USA

**Worldwide employees:** 600+

**President and CEO:** Dana Schurr

**Offering:** Heaters, flex circuits, sensors and instruments, integrated products, assembly

**Customers and markets:** Medical implants, medical diagnostics, aerospace, defense, semiconductor, power generation, oil and gas, rotating machinery, building automation, industrial and commercial



# Table of Contents

**Section 1: Temperature Sensor Assemblies**

- Tip-sensitive spring loaded .....1-2 to 1-3
- Tip-sensitive direct immersion .....1-4 to 1-5
- Tip-sensitive with thermowells .....1-6 to 1-7
- High temp. with thermowells .....1-8 to 1-9
- Explosionproof/Flameproof .....1-10 to 1-15
- Hazardous area .....1-16 to 1-21
- Eurostyle .....1-22 to 1-23
- Specifying custom assemblies .....1-24

**Section 2: Probes**

- Tip-sensitive RTDs and thermocouples .....2-2 to 2-3
- Fast response RTDs .....2-4 to 2-5
- Bayonet mount tip-sensitive RTDs, thermocouples .....2-6 to 2-7
- Electrically isolated RTDs, thermocouples .....2-8 to 2-9
- 550°C RTDs, thermocouples .....2-10 to 2-11
- 600°C RTDs .....2-12
- Mineral-insulated RTDs .....2-13
- Compact plug sensor .....2-14
- Integrated sensor transmitter .....2-15
- Conductivity level sensor .....2-16 to 2-17
- How to shorten cut-to-length probes .....2-18
- PFA, FEP encapsulation tubing .....2-18

**Section 3: Accessories**

- Connection heads .....3-2 to 3-3
- Spring-loaded holders .....3-4
- Fluid immersion fittings .....3-5
- Economy thermowells .....3-6
- HVAC thermowells .....3-6
- Reduced tip thermowells .....3-7
- Tapered thermowells .....3-7
- Flanged thermowells .....3-8
- Bayonet fittings .....3-9
- Extensions .....3-9
- Metric accessories .....3-10
- Feedthroughs .....3-11
- Leadwire and cable seal .....3-12 to 3-13
- Elastomer rubber-filled cable .....3-14
- Extension wire .....3-15

**Section 4: Instruments**

- RTD transmitters .....4-2 to 4-5, 4-8 to 4-9, 4-12 to 4-13
- Thermocouple transmitters .....4-6 to 4-7, 4-10 to 4-11, 4-14 to 4-15
- Programmable transmitters .....4-8 to 4-11
- Field rangeable transmitters .....4-12 to 4-15
- Programmable transmitters .....4-16 to 4-17
- HART® transmitters .....4-18 to 4-19
- Temperature range table .....4-20 to 4-21
- High accuracy calibration .....4-22
- Mounting accessories .....4-22
- Loop-powered indicators .....4-23 to 4-24
- CT224 12-channel monitor .....4-25 to 4-26
- CT424 Temperature Alarm/Monitor .....4-27 to 4-28
- CT325 miniature DC temperature controller .....4-29 to 4-30
- CT335 PC board mount temperature controller .....4-31 to 4-32
- CT435 PC board mount temperature controller .....4-33 to 4-34
- CT15 controller/alarm .....4-35 to 4-36
- CT16A temperature controller .....4-37 to 4-38
- CT15/CT16A accessories .....4-39
- CT425 Temperature Controller .....4-40 to 4-41

**Section 6: Miniature Sensors**

- Embedment RTDs .....6-2
- Embedment thermocouples .....6-3
- Increased Safety and Intrinsically Safe Sensors .....6-4 to 6-5
- Non-sparking embedment sensors .....6-6 to 6-9
- Bolt-on sensors .....6-10
- Economy sensors .....6-11
- Installation and accessories .....6-12

**Section 7: Stators RTDs**

- Increased safety RTDs .....7-2 to 7-3
- Single element RTDs .....7-4 to 7-5
- Dual element RTDs .....7-6
- Corona resistant RTD .....7-7
- Machinery protection products .....7-8

**Section 8: HVAC Sensors**

- Chill-Out™ combination sensor .....8-2 to 8-3
- Averaging temperature sensors .....8-4
- Duct and outside air temperature sensors .....8-5
- Room air temperature sensors .....8-6
- Flexible Thermal-Ribbon™ pipe sensors .....8-7
- Humidity sensor/transmitter assembly .....8-8 to 8-9
- Hazardous area humidity assembly .....8-10 to 8-11
- Intrinsically safe humidity assembly .....8-12 to 8-13
- Thermal Vial™ temperature sensing system .....8-14 to 8-15
- Refrigeration and freezer temperature system .....8-16
- Fluid immersion temperature sensors .....8-17
- Elements and probes .....8-18
- Temptran 4 to 20 mA transmitters .....8-19

**Section 9: Thermal-Ribbons™**

- Thermal-Ribbons™ .....9-2 to 9-3
- Thermal-Tabs™ .....9-2 to 9-3
- Discoil™ Thermal-Ribbons .....9-4
- Strip sensing Thermal-Ribbons .....9-5
- Thermistor Thermal-Ribbons .....9-6
- Thermocouple Thermal-Ribbons .....9-6
- Installation and accessories .....9-7

**Section 10: Elements**

- Wire-wound elements .....10-2
- Thin-film elements .....10-2
- Installation .....10-3
- Extension leads .....10-3

**Section 11: Technical Information**

- Your product guide .....11-2
- Many industry applications .....11-3
- Designed for optimal performance .....11-4 to 11-5
- Temptran™ temperature transmitters .....11-6
- RTD, thermocouple, or thermistor .....11-7
- Choosing sensor elements .....11-8
- RTD connections: 2-wire, 3-wire, 4-wire .....11-9
- Resistance/temperature tables .....11-10 to 11-11
- Thermocouple voltage/temperature tables .....11-11
- Temperature coefficient of resistance (TCR) .....11-12
- SensorCalc program .....11-12
- Miscellaneous specifications and codes .....11-12
- Material selection guide .....11-13

**Section 12: Reference**

- Part number index .....12-2 to 12-3
- Industry specifications .....12-4
- Global Resources .....12-5



**Look for the Minco Truck  
to order STOCKED PARTS!**

ASSEMBLIES

PROBES

ACCESSORIES

INSTRUMENTS

SANITARY SENSORS

MINIATURE SENSORS

STATOR RTDs

HVAC SENSORS

THERMAL-RIBBONS

ELEMENTS

TECHNICAL INFORMATION

REFERENCE





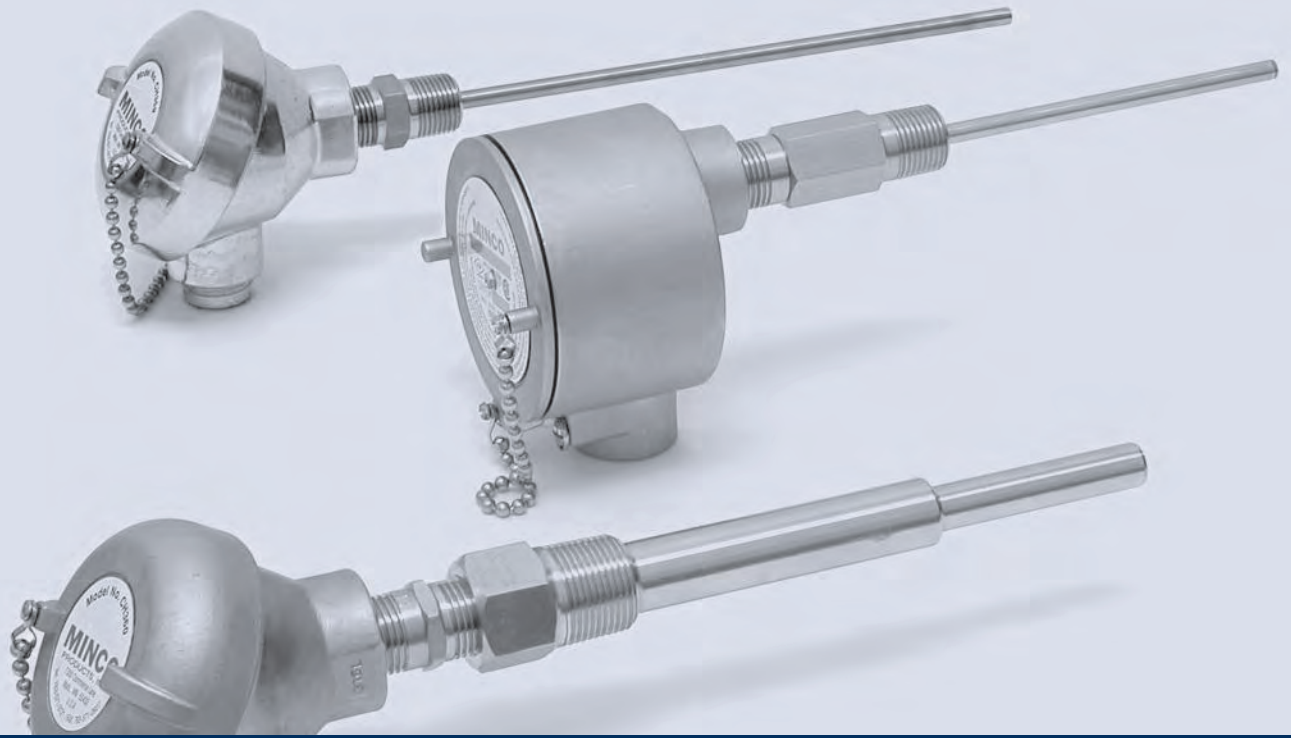

## ► SECTION 1: ASSEMBLIES

- Easy-to-order temperature sensor assemblies to fit a variety of applications
- RTDs, thermocouples, and transmitters
- Fittings, connection heads, and thermowells included
- Tip-sensitive, high temperature, explosionproof, and flameproof options

To specify custom assemblies see:

Probes	Section 2
Accessories	Section 3
Transmitters	Section 4

To specify humidity assemblies see  
Section 8

Tip-sensitive spring loaded.....	1-2 to 1-3
Tip-sensitive Direct immersion.....	1-4 to 1-5
Tip-sensitive with thermowells.....	1-6 to 1-7
High temp. with thermowells .....	1-8 to 1-9
Explosionproof/Flameproof.....	1-10 to 1-15
Hazardous area .....	1-16 to 1-21
Eurostyle.....	1-22 to 1-23
Specifying custom assemblies .....	1-24

# Tip-sensitive Spring-loaded RTDs

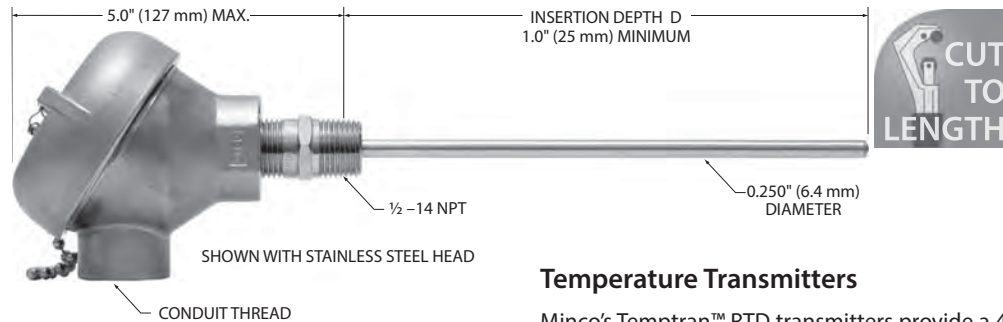

## Overview

Fast and accurate readings from bearings, blocks, and other solids. Minco's spring-loaded holder ensures solid contact in drilled holes and has a built-in oil seal. The sensing probe features a copper alloy tip for quick response to temperature changes.

- Tip-sensitive RTD probe for use to 260°C (500°F)
- Spring-loaded holder with fluid seal
- Cast iron, stainless steel, or aluminum connection head

## Specifications

**Temperature range:** -50 to 260°C (-58 to 500°F).

### Material:

Probe: Stainless steel with copper alloy tip.

Holder: Stainless steel with Viton O-ring.

Connection head: Cast iron, aluminum, or stainless steel.

**Pressure rating:** 50 psi (3.4 bar).

**Insulation resistance:** 100 megohms minimum at 100 VDC, leads to case.

**Connection:** Terminal block for wires to AWG 14.

**Time constant:** Typical value in moving water:

Single element: 1.5 seconds.

Dual element: 3.0 seconds.

## Sensing Elements

Element		Code
Platinum (0.00392 TCR)	100 Ω ±0.5% at 0°C	▼PA
Platinum (0.00385 TCR) (Meets EN60751, Class B)	100 Ω ±0.1% at 0°C	▼PD
Platinum (0.00385 TCR)	100 Ω ±0.5% at 0°C	PE
Copper (0.00427 TCR)	10 Ω ±0.2% at 25°C	CA
(dual)	10 Ω ±0.5% at 25°C	CC
Nickel (0.00672 TCR)	120 Ω ±0.5% at 0°C	NA

## Temperature Transmitters

Minco's Temptran™ RTD transmitters provide a 4 to 20 mA signal or HART® Protocol that can be sent over long distances with a simple 2-wire system. See Section 4 for complete temperature transmitter specifications.

**Special high-accuracy calibration:** For high system accuracy, specify transmitters with matched calibration. Calibration data traceable to NIST will also be provided. Get more information on page 4-22.

## Specification and order options

AS5004	Assembly number ▼ AS5004: Single element RTD ▼ AS5005: Dual element RTD
PA	Sensing element from table
60	Insertion depth D: Specify in 0.1" increments (Ex: 60 = 6.0 inches) ▼ :15, 20, 30, 40, 50, 60, 70, 80, 90, 100, 110, 120, 140, 160, 180, 200, 240, 300, 360
Z	Leads per sensing element: Y = 2 leads ▼ Z = 3 leads (required for CA and CC elements) X = 4 leads (PD elements only)
1	Conduit thread: ▼ 1 = 1/2 - 14 NPT 2 = 3/4 - 14 NPT
A	Connection head: C = Cast iron ▼ A = Aluminum S = Stainless steel
To order sensor assembly, stop here.	
To order with transmitters (single platinum element only) add:	
211	Temptran™ transmitter model: 211 = TT211: Fixed Range (2-lead RTDs) 508 = TT508: Programmable (2 & 3-lead RTDs) 511 = TT511: HART® Programmable (2, 3, & 4-lead RTDs)
A	Temperature range codes starting on page 4-20 or at <a href="http://www.minco.com">www.minco.com</a>
1	Calibration: 1 = Nominal calibration 2 = Match calibrated, 0.75% total system accuracy. For other calibration options, contact Minco
AS5004PA60Z1A211A1 = Sample part number	

▼ = STANDARD OPTIONS

Specifications subject to change

# Tip-sensitive Spring-loaded Thermocouples

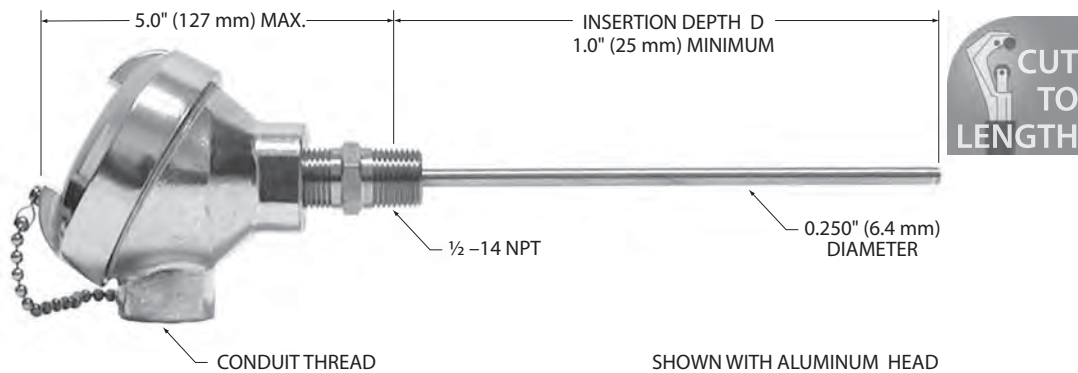

## Overview

Fast and accurate readings from bearings, blocks, and other solids. Minco's spring-loaded holder ensures solid contact in drilled holes and has a built-in oil seal. The sensing probe features a copper alloy tip for quick response to temperature changes.

- Tip-sensitive Thermocouple for use to 260°C (500°F)
- Spring-loaded holder with fluid seal
- Cast iron, stainless steel, or aluminum connection head

## Specifications

**Temperature range:** -50 to 260°C (-58 to 500°F).

### Material:

Probe: Stainless steel with copper alloy tip.  
 Holder: Stainless steel with Viton O-ring.  
 Connection head: Cast iron, aluminum, or stainless steel.

**Pressure rating:** 50 psi (3.4 bar).

**Insulation resistance:** 10 megohms minimum at 100 VDC, leads to case. Ungrounded junctions only.

**Connection:** Terminal block for wires to AWG 14.

**Time constant:** Typical value in moving water:

Grounded junction: 1.5 seconds.  
 Ungrounded junction: 7 seconds

## Temperature Transmitters

Minco's Temptran™ thermocouple transmitters provide a 4 to 20 mA signal or HART® Protocol that can be sent over long distances with a simple 2-wire system. See Section 4 for complete temperature transmitter specifications.

## Specification and order options

AS5192	<b>Assembly number</b> ▼AS5191: Single junction ▼AS5192: Dual junction
E	<b>Junction type:</b> ▼E = Chromel-Constantan J = Iron-Constantan ▼K = Chromel-Alumel T = Copper-Constantan
U	<b>Junction grounding:</b> G = Grounded ▼U = Ungrounded
120	<b>Insertion depth D:</b> Specify in 0.1" increments (Ex: 120 = 12.0 inches) ▼: 20, 30, 40, 50, 60, 70, 80, 90, 100, 110, 120
P	
1	<b>Conduit thread:</b> ▼1 = 1/2 - 14 NPT ▼2 = 3/4 - 14 NPT
A	<b>Connection head:</b> C = Cast iron ▼A = Aluminum S = Stainless steel
<b>To order sensor assembly, stop here.</b>	
<b>To order with transmitter, add:</b>	
509	<b>Temptran™ transmitter model:</b> 205 = TT205: Fixed Range, Miniature 509 = TT509: Programmable, Hockey Puck 511 = TT511: HART® Programmable, Hockey Puck
A	<b>Temperature range codes starting on page 4-20 or at <a href="http://www.minco.com">www.minco.com</a></b>
AS5192EU120P1A509A = Sample part number	

▼ = **STANDARD OPTIONS**  
 Specifications subject to change

# Tip-sensitive Direct Immersion RTDs

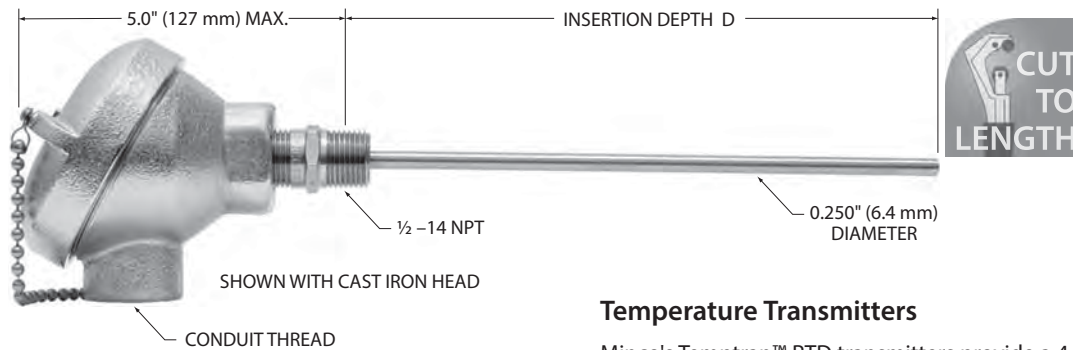

## Overview

Mount sensors directly in fluid flow for fast response. Probes are rated to 100 psi (6.9 bar). For use in non-corrosive fluids only.

- RTD probe for use to 260°C (500°F)
- Adjustable fluid seal fitting
- Cast iron, stainless steel, or aluminum connection head

## Specifications

**Temperature range:** -50 to 260°C (-58 to 500°F).

### Material:

Probe: Stainless steel with copper alloy tip.  
 Fitting: Stainless steel, silicone rubber O-ring.  
 Connection head: Cast iron, aluminum, or stainless steel.

**Pressure rating:** 100 psi (6.9 bar).

**Insulation resistance:** 100 megohms minimum at 100 VDC, leads to case.

**Connection:** Terminal block for wires to AWG 14.

**Time constant:** Typical value in moving water:  
 Single element: 2.0 seconds.  
 Dual element: 5.0 seconds.

## Sensing elements

Element		Code
Platinum (0.00392 TCR)	100 Ω ±0.5% at 0°C	PA
Platinum (0.00385 TCR) (Meets EN60751, Class B)	100 Ω ±0.1% at 0°C	▼PD
Platinum (0.00385 TCR)	100 Ω ±0.5% at 0°C	PE
Copper (0.00427 TCR)	10 Ω ±0.2% at 25°C	CA
(dual)	10 Ω ±0.5% at 25°C	CC
Nickel (0.00672 TCR)	120 Ω ±0.5% at 0°C	NA

## Temperature Transmitters

Minco's Temptran™ RTD transmitters provide a 4 to 20 mA signal or HART® Protocol that can be sent over long distances with a simple 2-wire system. See Section 4 for complete temperature transmitter specifications.

**Special high-accuracy calibration:** For high system accuracy, specify transmitters with matched calibration. Calibration data traceable to NIST will also be provided. Get more information on page 4-22.

## Specification and order options

AS5200	Assembly number ▼AS5200: Single element ▼AS5201: Dual element
PD	Sensing element from table
100	Insertion depth D: Specify in 0.1" increments (Ex: 100 = 10.0 inches) ▼:15, 20, 30, 40, 50, 60, 70, 80, 90, 100, 110, 120, 140, 160, 180, 200, 240, 300, 360
Z	Leads per sensing element: Y = 2 leads ▼Z = 3 leads (required for CA and CC elements) X = 4 leads (PD elements only)
1	Conduit thread: ▼1 = 1/2 - 14 NPT 2 = 3/4 - 14 NPT
A	Connection head: C = Cast iron ▼A = Aluminum S = Stainless steel
To order sensor assembly, stop here. To order with transmitters (single platinum element only) add:	
508	Temptran™ transmitter model: 211 = TT211: Fixed Range (2-lead RTDs) 508 = TT508: Programmable (2 & 3-lead RTDs) 511 = TT511: HART® Programmable (2, 3, & 4-lead RTDs)
A	Temperature range codes starting on page 4-20 or at <a href="http://www.minco.com">www.minco.com</a>
1	Calibration: 1 = Nominal calibration 2 = Match calibrated, 0.75% total system accuracy. For other calibration options, contact Minco
AS5200PD100Z1A508A1 = Sample part number	

▼ = STANDARD OPTIONS  
 Specifications subject to change



# Tip-sensitive Direct Immersion Thermocouples

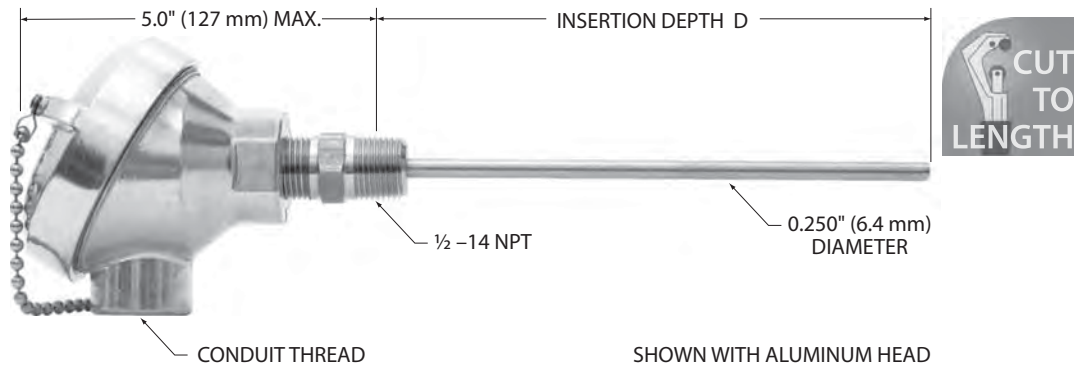

## Overview

Mount sensors directly in fluid flow for fast response. Probes are rated to 100 psi (6.9 bar). For use in non-corrosive fluids only.

- Thermocouple for use to 260°C (500°F)
- Adjustable fluid seal fitting
- Cast iron, stainless steel, or aluminum connection head

## Specifications

**Temperature range:** -50 to 260°C (-58 to 500°F).

### Material:

Probe: Stainless steel with copper alloy tip.  
 Fitting: Stainless steel, silicone rubber O-ring.  
 Connection head: Cast iron, aluminum, or stainless steel.

**Pressure rating:** 100 psi (6.9 bar).

**Insulation resistance:** 10 megohms minimum at 100 VDC, leads to case. Ungrounded junctions only.

**Connection:** Terminal block for wires to AWG 14.

**Time constant:** Typical value in moving water:

Grounded junction: 1.5 seconds.  
 Ungrounded junction: 7 seconds.

## Temperature Transmitters

Minco's Tempran™ thermocouple transmitters provide a 4 to 20 mA signal or HART® Protocol that can be sent over long distances with a simple 2-wire system. See Section 4 for complete temperature transmitter specifications.

## Specification and order options

AS5205	<b>Assembly number</b> AS5205: Single junction AS5206: Dual junction
E	<b>Junction type:</b> E = Chromel-Constantan J = Iron-Constantan K = Chromel-Alumel T = Copper-Constantan
U	<b>Junction grounding:</b> G = Grounded U = Ungrounded
215	<b>Insertion depth D:</b> Specify in 0.1" increments (Ex: 215 = 21.5 inches)
P	
1	<b>Conduit thread:</b> 1 = 1/2 - 14 NPT 2 = 3/4 - 14 NPT
C	<b>Connection head:</b> C = Cast iron A = Aluminum S = Stainless steel
<b>To order sensor assembly, stop here.</b>	
<b>To order with transmitter, add:</b>	
509	<b>Tempran™ transmitter model:</b> 205 = TT205: Fixed Range, Miniature 509 = TT509: Programmable, Hockey Puck 511 = TT511: HART® Programmable, Hockey Puck
A	<b>Temperature range codes starting on page 4-20 or at <a href="http://www.minco.com">www.minco.com</a></b>
AS5205EU215P1C509A = Sample part number	

▼ = **STANDARD OPTIONS**  
 Specifications subject to change

# Tip-sensitive RTDs with Thermowells

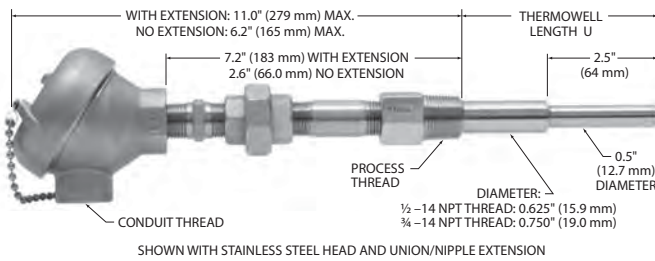

## Overview

Thermowells protect sensors from the effects of fluid flow and pressure. These assemblies are spring-loaded for positive probe contact against the bottom of the thermowell. The probe's copper alloy tip provides superior time response and reduces error from stem conduction.

- 316 stainless steel thermowell
- Tip-sensitive RTD probe for use to 260°C (500°F)
- Spring-loaded probe
- Cast iron, stainless steel, or aluminum connection head

## Specifications

**Temperature range:** -50 to 260°C (-58 to 500°F).

### Material:

Probe: Stainless steel with copper alloy tip.  
 Connection head: Cast iron, aluminum, or stainless steel.  
 Thermowell: 316 stainless steel.  
 Extension: Stainless steel.

**Pressure rating:** 7000 psi (483 bar) at 21°C, reducing to 6300 psi (433 bar) at 260°C.

**Standard U dimensions:** 2.5, 4.5, 6.0, 7.5, 8.0, 10.5, 13.5, 16.5, and 22.5".

**Insulation resistance:** 100 megohms minimum at 100 VDC, leads to case.

**Connection:** Terminal block for wires to AWG 14.

**Time constant:** 17 seconds typical in moving water.

## Sensing elements

Element		Code
Platinum (0.00392 TCR)	100 Ω ±0.5% at 0°C	PA
Platinum (0.00385 TCR) (Meets EN60751, Class B)	100 Ω ±0.1% at 0°C	▼PD
Platinum (0.00385 TCR)	100 Ω ±0.5% at 0°C	PE
Copper (0.00427 TCR)	10 Ω ±0.2% at 25°C	CA
(dual)	10 Ω ±0.5% at 25°C	CC
Nickel (0.00672 TCR)	120 Ω ±0.5% at 0°C	NA

## Temperature Transmitters

Minco's Temptran™ RTD transmitters provide a 4 to 20 mA signal or HART® Protocol that can be sent over long distances with a simple 2-wire system. See Section 4 for complete temperature transmitter specifications.

**Special high-accuracy calibration:** For high system accuracy, specify transmitters with matched calibration. Calibration data traceable to NIST will also be provided. Get more information on page 4-22.

## Specification and order options

AS5140	<b>Assembly number</b> ▼AS5140: Single element RTD ▼AS5141: Dual element RTD
CA	<b>Sensing element from table</b>
60	<b>Thermowell length U:</b> Specify in 0.1" increments (Ex: 60 = 6.0 inches) ▼:15, 20, 25, 30, 40, 45, 60, 75, 90, 100, 105, 120, 150
Z	<b>Leads per sensing element:</b> Y = 2 leads ▼Z = 3 leads (required for CA and CC elements) X = 4 leads (PD elements only)
1	<b>Conduit thread:</b> ▼1 = 1/2 - 14 NPT 2 = 3/4 - 14 NPT
A	<b>Connection head:</b> C = Cast iron ▼A = Aluminum S = Stainless steel
1	<b>Thermowell process thread:</b> ▼1 = 1/2 - 14 NPT 2 = 3/4 - 14 NPT
U	<b>Extension option:</b> P = Coupling/nipple extension ▼N = No extension ▼U = Union/Nipple extension
<b>To order sensor assembly, stop here.</b> <b>To order with transmitters (single platinum element only) add:</b>	
508	<b>Temptran™ transmitter model:</b> 211 = TT211: Fixed Range (2-lead RTDs) 508 = TT508: Programmable (2 & 3-lead RTDs) 511 = TT511: HART® Programmable (2, 3, & 4-lead RTDs)
A	<b>Temperature range codes starting on page 4-20 or at <a href="http://www.minco.com">www.minco.com</a></b>
1	<b>Calibration:</b> 1 = Nominal calibration 2 = Match calibrated, 0.75% total system accuracy. For other calibration options, contact Minco
<b>AS5140CA60Z21A1U508A1 = Sample part number</b>	

▼ = STANDARD OPTIONS  
 Specifications subject to change

# Tip-sensitive Thermocouples with Thermowells

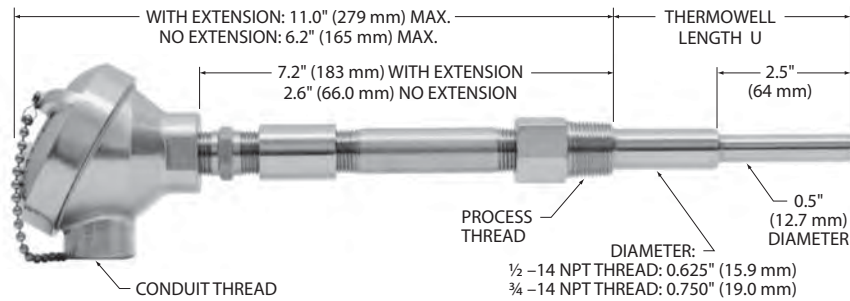

SHOWN WITH ALUMINUM HEAD AND COUPLING/NIPPLE EXTENSION

## Overview

Thermowells protect sensors from the effects of fluid flow and pressure. These assemblies are spring-loaded for positive probe contact against the bottom of the thermowell. The probe's copper alloy tip provides superior time response and reduces error from stem conduction.

- 316 stainless steel thermowell
- Tip-sensitive thermocouple for use to 260°C (500°F)
- Spring-loaded probe
- Cast iron, stainless steel, or aluminum connection head

## Specifications

**Temperature range:** -50 to 260°C (-58 to 500°F).

### Material:

Probe: Stainless steel with copper alloy tip.  
 Connection head: Cast iron, aluminum, or stainless steel.  
 Thermowell: 316 stainless steel.  
 Extension: Stainless steel.

**Pressure rating:** 7000 psi (483 bar) at 21°C, reducing to 6300 psi (433 bar) at 260°C.

**Standard U dimensions:** 2.5, 4.5, 6.0, 7.5, 8.0, 10.5, 13.5, 16.5, and 22.5".

**Insulation resistance:** 10 megohms min. at 100 VDC, leads to case. Ungrounded junctions only.

**Connection:** Terminal block for wires to AWG 14.

**Time constant:** Typical value in moving water.  
 Grounded junction: 17 seconds.  
 Ungrounded junction: 22 seconds.

## Temperature Transmitters

Minco's Temptran™ thermocouple transmitters provide a 4 to 20 mA signal or HART® Protocol that can be sent over long distances with a simple 2-wire system. See Section 4 for complete temperature transmitter specifications.

## Specification and order options

AS5145	<b>Assembly number</b> AS5145: Single junction TC AS5146: Dual junction TC
E	<b>Junction type:</b> E = Chromel-Constantan J = Iron-Constantan K = Chromel-Alumel T = Copper-Constantan
U	<b>Junction Grounding:</b> G = Grounded U = Ungrounded
135	<b>Thermowell length U:</b> Specify in 0.1" increments (Ex: 135 = 13.5 inches)
P	
1	<b>Conduit thread:</b> 1 = 1/2 - 14 NPT 2 = 3/4 - 14 NPT
C	<b>Connection head:</b> C = Cast iron A = Aluminum S = Stainless steel
1	<b>Thermowell process thread:</b> 1 = 1/2 - 14 NPT 2 = 3/4 - 14 NPT
U	<b>Extension option:</b> P = Coupling/nipple extension N = No extension U = Union/Nipple extension
<b>To order sensor assembly, stop here.</b>	
<b>To order with transmitter, add:</b>	
509	<b>Temptran™ transmitter model:</b> 205 = TT205: Fixed Range, Miniature 509 = TT509: Programmable, Hockey Puck 511 = TT511: HART® Programmable, Hockey Puck
A	<b>Temperature range codes starting on page 4-20 or at <a href="http://www.minco.com">www.minco.com</a></b>
AS5145EU135P1C1U509A = Sample part number	

▼ = STANDARD OPTIONS  
 Specifications subject to change

# 550°C RTDs with Thermowells

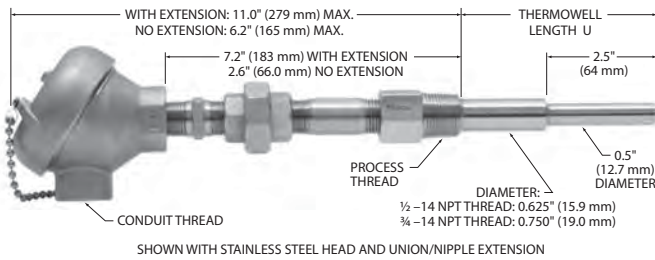

## Overview

Sense temperature in high-pressure fluids and gases. These assemblies are spring-loaded for positive probe contact against the bottom of the thermowell.

- 316 stainless steel thermowell
- RTD probe for use to 550°C (1022°F)
- Spring-loaded probe
- Cast iron, stainless steel, or aluminum connection head

*Note: For temperatures less than 260°C (500°F), assemblies using tip-sensitive sensors are recommended.*

## Specifications

### Temperature range:

Thermowell and sensor: -100 to 550°C (-148 to 1022°F).

### Connection head:

Cast iron: 260°C (500°F) max.

Aluminum: 316°C (600°F) max.

Stainless steel: 121°C (250°F) max.

### Material:

Probe: 316 stainless steel.

Connection head: Cast iron, aluminum, or stainless steel.

Thermowell: 316 stainless steel.

Extension: Stainless steel.

**Pressure rating:** 7000 psi (483 bar) at 21°C, reducing to 2500 psi (172 bar) at 550°C.

**Standard U dimensions:** 2.5, 4.5, 6.0, 7.5, 8.0, 10.5, 13.5, 16.5, and 22.5".

**Insulation resistance:** 10 megohms min. at 100 VDC, leads to case.

**Connection:** Terminal block for wires to 14 AWG.

**Time constant:** 23 seconds typical in moving water.

## Sensing elements

Element		Code
Platinum (0.00391 TCR)	100 Ω ±0.1% at 0°C	PB
Platinum (0.00385 TCR) (Meets EN60751, Class B)	100 Ω ±0.1% at 0°C	PD

## Temperature Transmitters

Minco's Temptran™ RTD transmitters provide a 4 to 20 mA signal or HART® Protocol that can be sent over long distances with a simple 2-wire system. See Section 4 for complete temperature transmitter specifications.

**Special high-accuracy calibration:** For high system accuracy, specify transmitters with matched calibration. Calibration data traceable to NIST will also be provided. Get more information on page 4-22.

## Specification and order options

AS5160	Assembly number AS5160
PB	Sensing element from table
105	Thermowell length U: Specify in 0.1" increments (Ex: 105 = 10.5 inches)
Z	Leads per sensing element: Y = 2 leads Z = 3 leads X = 4 leads (PD elements only)
2	Conduit thread: 1 = 1/2 - 14 NPT 2 = 3/4 - 14 NPT
C	Connection head: C = Cast iron A = Aluminum S = Stainless steel
1	Thermowell process thread: 1 = 1/2 - 14 NPT 2 = 3/4 - 14 NPT
U	Extension option: P = Coupling/nipple extension N = No extension U = Union/Nipple extension
To order sensor assembly, stop here.	
To order with transmitters add:	
508	Temptran™ transmitter model: 211 = TT211: Fixed Range (2-lead RTDs) 508 = TT508: Programmable (2 & 3-lead RTDs) 511 = TT511: HART® Programmable (2, 3, & 4-lead RTDs)
A	Temperature range codes starting on page 4-20 or at <a href="http://www.minco.com">www.minco.com</a>
1	Calibration: 1 = Nominal calibration 2 = Match calibrated, 0.75% total system accuracy. For other calibration options, contact Minco
AS5160PB105Z2C1U508A1 = Sample part number	

▼ = STANDARD OPTIONS

Specifications subject to change

# 550°C Thermocouples with Thermowells

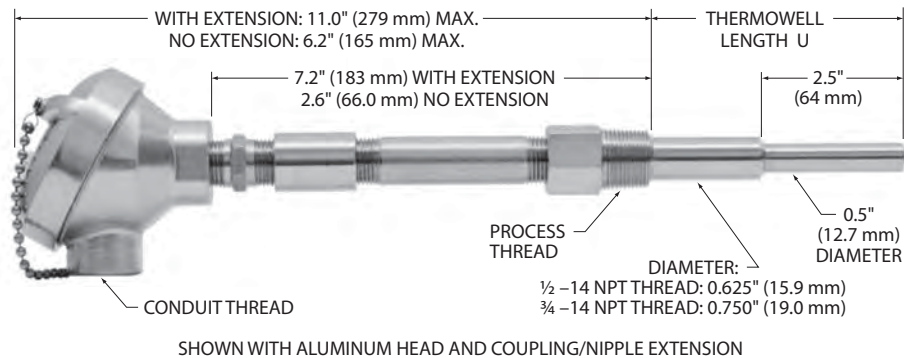

## Overview

Sense temperature in high-pressure fluids and gases. These assemblies are spring-loaded for positive probe contact against the bottom of the thermowell.

*Note: For temperatures less than 260°C (500°F), assemblies using tip-sensitive sensors are recommended.*

- 316 stainless steel thermowell
- Thermocouple probe for use to 550°C (1022°F)
- Spring-loaded probe
- Cast iron, aluminum or stainless steel connection head

## Specifications

### Temperature range:

Thermowell and sensor: -100 to 550°C (-148 to 1022°F).

Connection head:

Cast iron: 260°C (500°F) max.

Aluminum: 316°C (600°F) max.

Stainless steel: 121°C (250°F) max.

### Material:

Probe: 316 stainless steel.

Connection head: Cast iron, aluminum, or stainless steel.

Thermowell: 316 stainless steel.

Extension: Stainless steel.

**Pressure rating:** 7000 psi (483 bar) at 21°C, reducing to 2500 psi (172 bar) at 550°C.

### Standard U dimensions:

2.5, 4.5, 6.0, 7.5, 8.0, 10.5, 13.5, 16.5, and 22.5".

**Insulation resistance:** 10 megohms min. at 100 VDC, leads to case. Ungrounded junctions only.

**Connection:** Terminal block for wires to 14 AWG.

**Time constant:** 60 seconds typical in moving water.

## Temperature Transmitters

Minco's Temptran™ thermocouple transmitters provide a 4 to 20 mA signal or HART® Protocol that can be sent over long distances with a simple 2-wire system. See Section 4 for complete temperature transmitter specifications.

## Specification and order options

AS5165	Assembly number: AS5165
K	Junction type: E = Chromel-Constantan J = Iron-Constantan K = Chromel-Alumel
U	Junction Grounding: G = Grounded U = Ungrounded
135	Thermowell length U: Specify in 0.1" increments (Ex: 135 = 13.5 inches)
P	
1	Conduit thread: 1 = 1/2 - 14 NPT 2 = 3/4 - 14 NPT
C	Connection head: C = Cast iron A = Aluminum S = Stainless steel
1	Thermowell process thread: 1 = 1/2 - 14 NPT 2 = 3/4 - 14 NPT
U	Extension option: P = Coupling/nipple extension N = No extension U = Union/Nipple extension
To order sensor assembly, stop here. To order with transmitter, add:	
509	Temptran™ transmitter model: 205 = TT205: Fixed Range, Miniature 509 = TT509: Programmable, Hockey Puck 511 = TT511: HART® Programmable, Hockey Puck
A	Temperature range codes starting on page 4-20 or at <a href="http://www.minco.com">www.minco.com</a>
AS5165KU135P1C1U509A = Sample part number	

▼ = STANDARD OPTIONS  
Specifications subject to change

# Explosionproof/Flameproof RTD Sensors

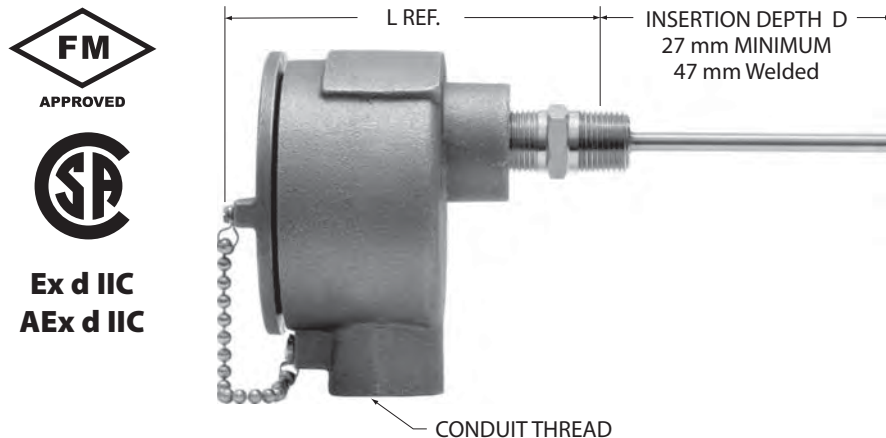

## Overview

Explosionproof and flameproof rating for hazardous areas where accurate temperature sensing is critical.

- Tip sensitive, all stainless or MgO filled probes available
- Hazardous area rated
- High temp process temperature options (600°C) available. Contact Minco for more information.

## Specifications

### Temperature range:

- 50 to 260°C (-58 to 500°F)
- 50 to 600°C (-58 to 1112°F) for MgO Probes

### Material:

Probe: Stainless steel (tip sensitive models have copper alloy tip).  
Holder: Stainless steel.  
Connection head:  
Copper free aluminum alloy (CH104)  
316 stainless steel (CH106).

**Pressure rating:** See table on next page.

**Insulation resistance:** 10 megohms min. at 100 VDC, leads to case.

**Connection:** Terminal block for wires to 14 AWG.

**Time constant:** Typical value in moving water.

Tip sensitive:

- Single element 1.5 seconds.
- Dual element 5 seconds.

All stainless and MgO filled: 10 seconds.

## Explosionproof and flameproof ratings:

National and Canadian Electrical Code:

- Class I, Divisions 1 and 2, Groups B, C, and D,
- Class II, Groups E, F, and G,
- T6 (Ta = 40°C),
- T2 (Ta = 260°C). Ta limited to 160°C for CSA Class II locations.

National Electrical Code (Article 505):

- Class I, Zones 1 and 2, AEx d IIC,
- T6 (Ta = 40°C), T2 (Ta = 260°C).

Canadian Electrical Code (IEC 60079):

- Zones 1 and 2, Ex d IIC,
- T6 (Ta = 40°C), T2 (Ta = 260°C).

## Hazardous area requirements

For more information on how to classify a hazardous area, methods of protection, and the various standards and agencies (including FM, CSA, IECEx and ATEX), visit [www.minco.com](http://www.minco.com).

▼ = **STANDARD OPTIONS**  
Specifications subject to change

## Assembly numbers

Probe diameters	0.215" (5.5 mm)		0.236" (6.0 mm)		0.250" (6.4 mm)	
Number of elements	Single	Dual	Single	Dual	Single	Dual
Tip-sensitive	AS760	AS761	AS700	AS701	▼AS720	▼AS721
All stainless	AS762	AS763	AS702	AS703	AS722	AS723
MgO filled (platinum only)			AS704		AS724	AS725

## Connection head and fitting options

CH104: Aluminum IP65, Type 3 and 4.

CH106: 316 stainless steel IP66, Type 3, 4, and 4X.

Fitting	Process thread	Pressure Rating	L REF.	Code	Minimum Insertion Depth (mm)
Welded	1/2 - 14 NPT	200 psi (13.8 bar)	4.4" (112 mm)	0*	47
Welded	G 1/2	200 psi (13.8 bar)	4.2" (107 mm)	2*	47
Adjustable spring-loaded	1/2 - 14 NPT	50 psi (3.4 bar)	5.7" (144 mm)	▼4	27
Adjustable spring-loaded	G 1/2	50 psi (3.4 bar)	5.7" (144 mm)	6	27
Fixed spring-loaded	1/2 - 14 NPT	None	4.4" (112 mm)	8**	27

\* 0.250 diameter only for all stainless and MgO probes (not available in tip-sensitive, 0.215" diameter or 0.236" diameter probes).

\*\* 0.236 and 0.250 diameters only for fixed spring-loaded fittings.

Note: Connection head dimensions are found on pages 3-2 to 3-3.

## Sensing elements

Element	Code	Code	
		Single	Dual
Platinum (0.00392 TCR) 100 $\Omega$ $\pm$ 0.5% at 0°C	PA	PAPA	
Platinum (0.00385 TCR) 100 $\Omega$ $\pm$ 0.1% at 0°C (Meets EN60751, Class B)	▼PD	PDPD	
Platinum (0.00385 TCR) 100 $\Omega$ $\pm$ 0.06% at 0°C (Meets EN60751, Class A)	PM	PMPM	
Platinum (0.00385 TCR) 100 $\Omega$ $\pm$ 0.5% at 0°C	PE	PEPE	
Platinum (0.00375 TCR) 1000 $\Omega$ $\pm$ 0.12% at 0°C	PW	PWPW	
Copper (0.00427 TCR) (dual) 10 $\Omega$ $\pm$ 0.2% at 25°C 10 $\Omega$ $\pm$ 0.5% at 25°C	CA		
		CCCC	
Nickel (0.00672 TCR) 120 $\Omega$ $\pm$ 0.5% at 0°C	NA	NANA	
Nickel (0.00618 TCR) 100 $\Omega$ $\pm$ 0.22% at 0°C	NB	NBNB	

## Specification and order options

AS720	Assembly number from table
4	Fitting from table
PD	Sensing element from table
100	Insertion depth D (mm): See table for minimums ▼:76, 100, 127, 150, 178, 200, 229, 250, 279, 305, 350, 406, 457, 500, 610
Z	Leads per sensing element: Y = 2 leads (n/a for copper) ▼Z = 3 leads X = 4 leads
3	Conduit thread: ▼3 = 1/2 - 14 NPT 4 = 3/4 - 14 NPT
A	Connection head material: A = Aluminum S = 316 Stainless Steel
0	Extension: 0 = No Extension 2 = 1/2 NPT Nipple (2")/Union (2.6" length adder) 3 = 1/2 NPT Nipple (3")/Union (3.6" length adder) 4 = 1/2 NPT Nipple (4")/Union (4.6" length adder) 6 = 1/2 NPT Nipple (6")/Union (6.6" length adder)
X0X	No Thermowell
AS7204PD100Z3A0X0X= Sample part number	

▼ = STANDARD OPTIONS

Specifications subject to change

# Explosionproof/Flameproof Thermocouple Sensors



**Ex d IIC  
AEx d IIC**

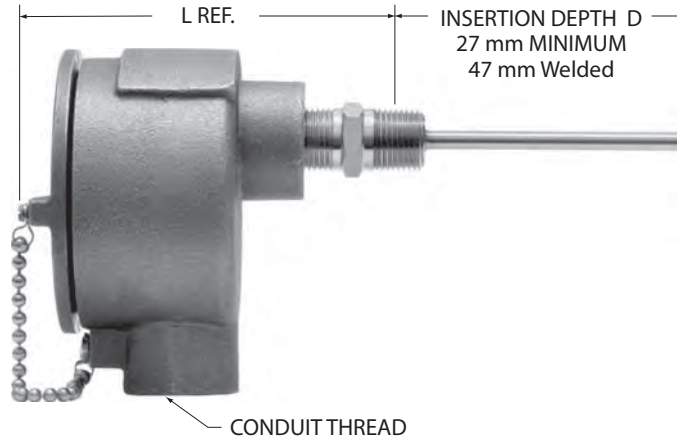

## Overview

Explosionproof and flameproof rating for hazardous areas where accurate temperature sensing is critical.

- Tip sensitive, MgO filled probes available
- Hazardous area rated

## Specifications

### Temperature range:

- 50 to 260°C (-58 to 500°F)
- 50 to 600°C (-58 to 1112°F) for MgO Probes

### Material:

Probe: Stainless steel (tip sensitive models have copper alloy tip).

Holder: Stainless steel.

Connection head:

- Copper free aluminum alloy (CH104)
- 316 stainless steel (CH106).

**Pressure rating:** See table on next page.

**Insulation resistance:** 10 megohms min. at 100 VDC, leads to case. Ungrounded junctions only.

**Connection:** Terminal block for wires to 14 AWG.

**Time constant:** Typical value in moving water.

Tip sensitive:

- Grounded 1.5 seconds.
- Ungrounded 7 seconds.

MgO filled:

- Grounded: 1.5 seconds.
- Ungrounded: 5.0 seconds.

## Explosionproof and flameproof ratings:

National and Canadian Electrical Code:

- Class I, Divisions 1 and 2, Groups B, C, and D,
- Class II, Groups E, F, and G,
- T6 (Ta = 40°C),
- T2 (Ta = 260°C). Ta limited to 160°C for CSA Class II locations.

National Electrical Code (Article 505):

- Class I, Zones 1 and 2, AEx d IIC,
- T6 (Ta = 40°C), T2 (Ta = 260°C).

Canadian Electrical Code (IEC 60079):

- Zones 1 and 2, Ex d IIC,
- T6 (Ta = 40°C), T2 (Ta = 260°C).

## Temperature Transmitters

Minco's Tempran™ RTD transmitters provide a 4 to 20 mA signal or HART® Protocol that can be sent over long distances with a simple 2-wire system. See Section 4 for complete temperature transmitter specifications.

Contact Minco if transmitter is required

## Hazardous area requirements

For more information on how to classify a hazardous area, methods of protection, and the various standards and agencies (including FM, CSA, IECEx and ATEX), visit [www.minco.com](http://www.minco.com).

▼ = **STANDARD OPTIONS**  
Specifications subject to change



## Connection head and fitting options

CH104: Aluminum IP65, Type 3 and 4.

CH106: 316 stainless steel IP66, Type 3, 4, and 4X.

Fitting	Process thread	Pressure Rating	L REF.	Code	Minimum Insertion Depth (mm)
Welded	1/2 - 14 NPT	200 psi (13.8 bar)	4.4" (112 mm)	0*	47
Welded	G 1/2	200 psi (13.8 bar)	4.2" (107 mm)	2*	47
Adjustable spring-loaded	1/2 - 14 NPT	50 psi (3.4 bar)	5.7" (144 mm)	4	27
Adjustable spring-loaded	G 1/2	50 psi (3.4 bar)	5.7" (144 mm)	6	27
Fixed spring-loaded	1/2 - 14 NPT	None	4.4" (112 mm)	8**	27

\* Welded fitting only available with 0.250 MgO filled probes [minimum insertion (2.5" 63mm)]

\*\* 0.236 and 0.250 diameters only for fixed spring-loaded fittings.

Note: Connection head dimensions are found on pages 3-2 to 3-3.

## Assembly numbers

Probe diameters	0.215" (5.5 mm)		0.236" (6.0 mm)		0.250" (6.4 mm)	
	Single	Dual	Single	Dual	Single	Dual
Number of elements						
Tip-sensitive	AS766	AS767	AS706	AS707	AS726	AS727
MgO filled			AS708	AS709	AS728	AS729

## Specification and order options

AS706	Assembly number from table
4	Fitting from table
E	Junction type from table
U	Junction Grounding: G = Grounded U = Ungrounded
100	Insertion depth D (mm): See table for minimums
P	
3	Conduit thread: 3 = 1/2 - 14 NPT 4 = 3/4 - 14 NPT
A	Connection head material: A = Aluminum S = 316 Stainless Steel
0	Extension: 0 = No Extension 2 = 1/2 NPT Nipple (2")/Union (2.6" length adder) 3 = 1/2 NPT Nipple (3")/Union (3.6" length adder) 4 = 1/2 NPT Nipple (4")/Union (4.6" length adder) 6 = 1/2 NPT Nipple (6")/Union (6.6" length adder)
X0X	No Thermowell
AS7064EU100P3A0X0X = Sample part number	

## Junction types

Thermocouple Junction	
Chromel-Constantan	E
Iron-Constantan	J
Chromel-Alumel	K
Copper-Constantan	T

▼ = STANDARD OPTIONS

Specifications subject to change

# Explosionproof/Flameproof RTDs with Transmitters

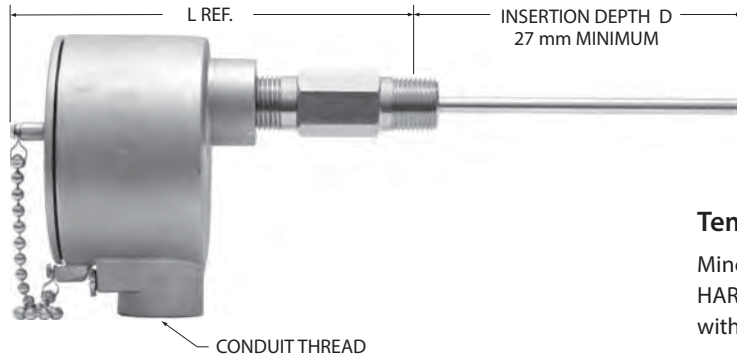

**Ex d IIC**  
**AEx d IIC**

## Overview

- Tip sensitive, all stainless or MgO filled RTD probe
- Temptran™ transmitter for long signal path

## Specifications

### Temperature range:

- 50 to 260°C (-58 to 500°F)
- 50 to 600°C (-58 to 1112°F) for MgO Probes

### Material:

- Probe: Stainless steel (tip sensitive models have copper alloy tip).
- Holder: Stainless steel.
- Connection head:
  - Copper free aluminum alloy (CH104)
  - 316 stainless steel (CH106).

**Pressure rating:** See table on next page.

**Insulation resistance:** 10 megohms min. at 100 VDC, leads to case.

**Connection:** Terminal block for wires to 14 AWG.

**Time constant:** Typical value in moving water.

Tip sensitive:

- Single element 1.5 seconds.
- Dual element 5 seconds.

All stainless and MgO filled: 10 seconds.

### Explosionproof and flameproof ratings:

- National and Canadian Electrical Code:
  - Class I, Divisions 1 and 2, Groups B, C, and D,
  - Class II, Groups E, F, and G,
  - T6 (Ta = 40°C),
  - T2 (Ta = 260°C). Ta limited to 160°C for CSA Class II locations.

National Electrical Code (Article 505):

- Class I, Zones 1 and 2, AEx d IIC,
- T6 (Ta = 40°C), T2 (Ta = 260°C).

Canadian Electrical Code (IEC 60079):

- Zones 1 and 2, Ex d IIC,
- T6 (Ta = 40°C), T2 (Ta = 260°C).

## Temperature Transmitters

Minco's Temptran™ RTD transmitters provide a 4 to 20 mA or HART® Protocol signal that can be sent over long distances with a simple 2-wire system.

### Leadwires:

- 2-lead RTD: TT211, TT520, TT521
- 3-lead RTD: TT520, TT521
- 4-lead RTD: TT520, TT521

**Physical:** Epoxy potted for moisture resistance.

See Section 4 for complete temperature transmitter specifications.

### Hazardous area requirements

For more information on how to classify a hazardous area, methods of protection, and the various standards and agencies (including FM, CSA, IECEx and ATEX), visit [www.minco.com](http://www.minco.com).

## Assembly numbers

Probe diameters	0.215" (5.5 mm)	0.236" (6.0 mm)	0.250" (6.4 mm)
Tip-sensitive	AS760	AS700	AS720
All stainless	AS762	AS702	AS722
MgO filled		AS704	AS724

## Sensing elements

Element		Code: Single
Platinum (0.00392 TCR)	100 Ω ±0.5% at 0°C	PA
Platinum (0.00385 TCR)	100 Ω ±0.1% at 0°C (Meets EN60751, Class B)	PD
Platinum (0.00385 TCR)	100 Ω ±0.06% at 0°C (Meets EN60751, Class A)	PM
Platinum (0.00385 TCR)	100 Ω ±0.5% at 0°C	PE
Platinum (0.00375 TCR)	1000 Ω ±0.12% at 0°C	PW
Copper (0.00427 TCR)	10 Ω ±0.2% at 25°C	CA
Nickel (0.00672 TCR)	120 Ω ±0.5% at 0°C	NA
Nickel (0.00618 TCR)	100 Ω ±0.22% at 0°C	NB

▼ = STANDARD OPTIONS  
Specifications subject to change

## Connection head and fitting options

CH104: Aluminum IP65, Type 3 and 4.

CH106: 316 stainless steel IP66, Type 3, 4, and 4X.

Fitting	Process thread	Pressure Rating	L REF.	Head	Code	Minimum Insertion Depth (mm)
Welded	1/2 - 14 NPT	200 psi (13.8 bar)	4.4" (112 mm)	CH104	0*	47
Welded	1/2 - 14 NPT	200 psi (13.8 bar)	4.2" (106 mm)	CH106	1*	47
Welded	G 1/2	200 psi (13.8 bar)	4.2" (107 mm)	CH104	2*	47
Welded	G 1/2	200 psi (13.8 bar)	4.0" (101 mm)	CH106	3*	47
Adjustable spring-loaded	1/2 - 14 NPT	50 psi (3.4 bar)	5.7" (144 mm)	CH104	4	27
Adjustable spring-loaded	1/2 - 14 NPT	50 psi (3.4 bar)	5.4" (138 mm)	CH106	5	27
Adjustable spring-loaded	G 1/2	50 psi (3.4 bar)	5.7" (144 mm)	CH104	6	27
Adjustable spring-loaded	G 1/2	50 psi (3.4 bar)	5.4" (138 mm)	CH106	7	27
Fixed spring-loaded	1/2 - 14 NPT	None	4.4" (112 mm)	CH104	8**	27
Fixed spring-loaded	1/2 - 14 NPT	None	4.2" (106 mm)	CH106	9**	27

\* 0.250 diameter only for all stainless and MgO probes.  
(not available in tip-sensitive, 0.215" diameter or 0.236" diameter probes)

\*\* 0.236 and 0.250 diameters only for fixed spring-loaded fittings.  
Note: Connection head dimensions are found on page 3-2.

## Temperature transmitter range codes

Popular ranges below. More range codes starting on page 4-20 and at [www.minco.com](http://www.minco.com)

Code	Range	
EO	-50 to 100°C	-58 to 212°F
BC	-30 to 30°C	-22 to 86°F
S	-17.8 to 37.8°C	0 to 100°F
AC	-17.8 to 93.3°C	0 to 200°F
AN	-17.8 to 148.9°C	0 to 300°F
AG	-17.8 to 260°C	0 to 500°F
AP	-6.7 to 21.1°C	20 to 70°F
A	-6.7 to 48.9°C	20 to 120°F
N	0 to 50°C	32 to 122°F
C	0 to 100°C	32 to 212°F
J	0 to 150°C	32 to 302°F
K	0 to 200°C	32 to 392°F
V	10 to 65.6°C	50 to 150°F
P	37.8 to 179.4°C	100 to 355°F
BH	50 to 150°C	122 to 302°F

▼ = STANDARD OPTIONS

Specifications subject to change

## Specification and order options

AS720	Assembly number from table
4	Fitting from table
PD	Sensing element from table
100	Insertion depth D (mm): See table for minimums ▼:76, 100, 127, 150, 178, 200, 229, 250, 279, 305, 350, 406, 457, 500, 610
Z	Leads per sensing element: Y = 2 leads (n/a for copper) ▼Z = 3 leads X = 4 leads
3	Conduit thread: 3 = 1/2 - 14 NPT 4 = 3/4 - 14 NPT
A	Connection head material: A = Aluminum S = 316 Stainless Steel
0	Extension: 0 = No Extension 2 = 1/2 NPT Nipple (2")/Union (2.6" length adder) 3 = 1/2 NPT Nipple (3")/Union (3.6" length adder) 4 = 1/2 NPT Nipple (4")/Union (4.6" length adder) 6 = 1/2 NPT Nipple (6")/Union (6.6" length adder)
X0X	No Thermowell
1	Temptran™ code: 1 = TT518: Programmable Hockey Puck (2 or 3-lead RTDs) 2 = TT519: Programmable Hockey Puck (Thermocouple only) 4 = TT211: Fixed range Rectangular (2-lead RTDs) 7 = TT521: HART® Programmable Hockey Puck (2, 3, or 4-lead RTDs or Thermocouples)
N	Temperature range code from table
1	Calibration: 1 = Nominal calibration 2 = Match calibrated, 0.75% total system accuracy. For other calibration options, contact Minco
AS7204PD100Z3A0X0X1N1 = Sample part number	

# Flameproof, Increased Safety and Intrinsic Safety RTD Sensors – Per European and International Requirements

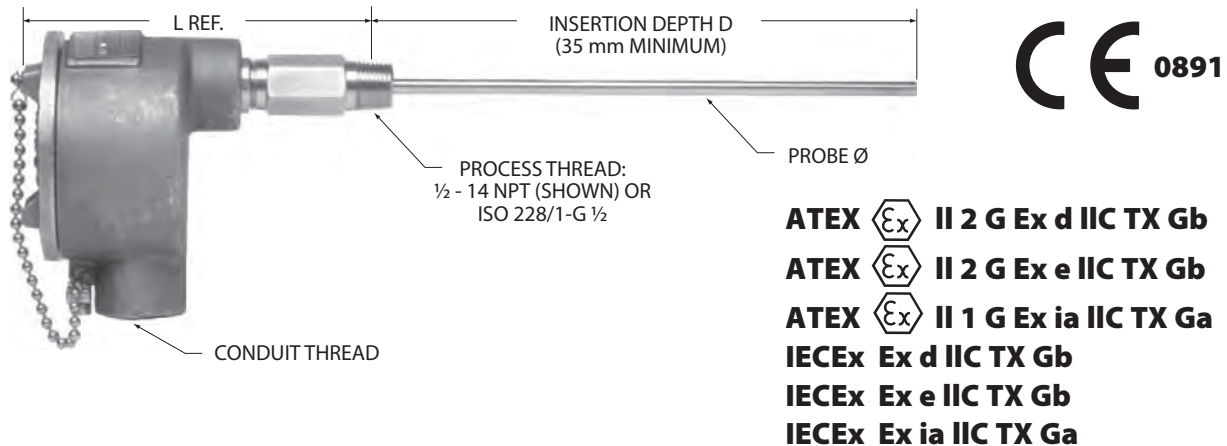

## Overview

Complies with European standards for electrical apparatus for potentially explosive atmospheres: ATEX Directive 94/9/EC and International IECEx certification schemes for explosive atmospheres.

- Flameproof assemblies can be used in Zones 1 or 2
- Increased safety assemblies can be used in Zones 1 or 2
- Intrinsic safety assemblies can be used in Zones 0, 1 or 2 when used with an appropriate barrier
- Features tip-sensitive, all stainless or MgO filled RTD probe for fast response
- Spring-loaded holder ensures good probe contact
- U.S. or metric threads

## Specifications

### Temperature range:

- 50 to 260°C (-58 to 500°F)
- 50 to 600°C (-58 to 1112°F) for MgO Probes

### Material:

- Tip-sensitive probe: Stainless steel with copper alloy tip.
- All stainless RTD: Stainless steel.
- MgO filled RTD: Stainless steel.
- Fittings: Stainless steel.
- Connection head:
  - CH356: 316 stainless steel IP66, Type 3, 4, and 4X.
  - CH357: Aluminum alloy IP65, Type 3 and 4.
  - CH358: Epoxy coated aluminum alloy IP66, Type 3, 4, and 4X.

### Pressure rating:

- Spring-loaded holder: 50 psi (3.4 bar).
- Fluid seal fitting: 100 psi (6.9 bar).

**Insulation resistance:** 100 megohms min. at 100 VDC, leads to probe case.

**Connection:** Terminal block for wires up to AWG 14.

**Time constant:** Typical value in moving water.

Tip sensitive:

- Single element 1.5 seconds.
- Dual element 7 seconds.
- All stainless and MgO filled: 10 seconds.

### Hazardous area requirements

For more information on how to classify a hazardous area, methods of protection, and the various standards and agencies (including FM, CSA, IECEx and ATEX), visit [www.minco.com](http://www.minco.com).

▼ = **STANDARD OPTIONS**  
 Specifications subject to change

## Fitting options

Fitting	Process Thread	L REF.		Code	Pressure Rating
		CH356	CH357/CH358		
Fluid Seal	1/2 - 14 NPT		4.6" (116 mm)	0*	50psi (3.4 bar)
Fluid Seal	G 1/2		4.4" (111 mm)	1*	50psi (3.4 bar)
Set screw spring-loaded	1/2 - 14 NPT	5.3" (135 mm)	5.6" (143 mm)	2	50psi (3.4 bar)
Set screw spring-loaded	G 1/2	5.0" (128mm)	5.4" (136 mm)	3	50psi (3.4 bar)
Fixed spring-loaded	1/2 - 14 NPT	4.5" (115 mm)		4	None
Welded	1/2 - 14 NPT	4.2"(107 mm)	4.5" (115 mm)	6**	200psi (13.8 bar)
Welded	G 1/2	4.0" (101 mm)	4.3" (109 mm)	7**	200psi (13.8 bar)
Release knob spring-loaded	1/2 - 14 NPT	5.4" (137 mm)	5.7" (145 mm)	8	50psi (3.4 bar)
Release knob spring-loaded	G 1/2	5.2" (132 mm)	5.5" (140 mm)	9	50psi (3.4 bar)

\* Not available with CH356 stainless steel connection head.

\*\* 0.250" (6.4mm) for all stainless and MgO only (not available in tip-sensitive or 0.236" diameter models).

## RTD Assembly Numbers

Probe Diameters	0.236" (6.0mm)		0.250" (6.4mm)	
	Single	Dual	Single	Dual
Tip Sensitive	AS800	AS801	AS810	AS811
All Stainless	AS802	AS803	AS812	AS813
MgO Platinum	AS804		AS814	AS815

### Notes:

CH356: 316 stainless steel IP66, Type 3, 4, and 4X.

CH357: Aluminum alloy IP65, Type 3 and 4.

CH358: Epoxy coated aluminum alloy IP66, Type 3, 4, and 4X.

Get more information on connection heads on pages 3-2 to 3-3.

## Sensing elements

Element	Code	Code	
		Single	Dual
Platinum (0.00392 TCR) 100 Ω ±0.5% at 0°C	PA	PAPA	
Platinum (0.00385 TCR) 100 Ω ±0.1% at 0°C (Meets EN60751, Class B)	PD	PDPD	
Platinum (0.00385 TCR) 100 Ω ±0.06% at 0°C (Meets EN60751, Class A)	PM	PMPM	
Platinum (0.00385 TCR) 100 Ω ±0.5% at 0°C	PE	PEPE	
Platinum (0.00375 TCR) 1000 Ω ±0.12% at 0°C	PW	PWPW	
Copper (0.00427 TCR) 10 Ω ±0.2% at 25°C	CA		
(dual) 10 Ω ±0.5% at 25°C		CCCC	
Nickel (0.00672 TCR) 120 Ω ±0.5% at 0°C	NA	NANA	
Nickel (0.00618 TCR) 100 Ω ±0.22% at 0°C	NB	NBNB	

## Specification and order options

AS800	Assembly number from table
4	Fitting from table
PD	Sensing element from table
100	Insertion depth D (in mm): (35-3000 mm)
X	Leads per sensing element: Y = 2 leads (n/a for copper) Z = 3 leads X = 4 leads (n/a for dual models)
3	Conduit thread: 3 = 1/2 - 14 NPT 4 = 3/4 - 14 NPT 5 = M20 x 1.5
A	Connection head material: A = Aluminum S = 316 Stainless Steel E = Aluminum, epoxy coated
0	Extension: 0 = No Extension 2 = 1/2 NPT Nipple (2")/Union (2.6" length adder) 3 = 1/2 NPT Nipple (3")/Union (3.6" length adder) 4 = 1/2 NPT Nipple (4")/Union (4.6" length adder) 6 = 1/2 NPT Nipple (6")/Union (6.6" length adder)
X0X	No Thermowell
AS8004PD100X3A0X0X = Sample part number	

▼ = STANDARD OPTIONS

Specifications subject to change

# Flameproof, Increased Safety and Intrinsic Safety Thermocouple Sensors – Per European and International Requirements

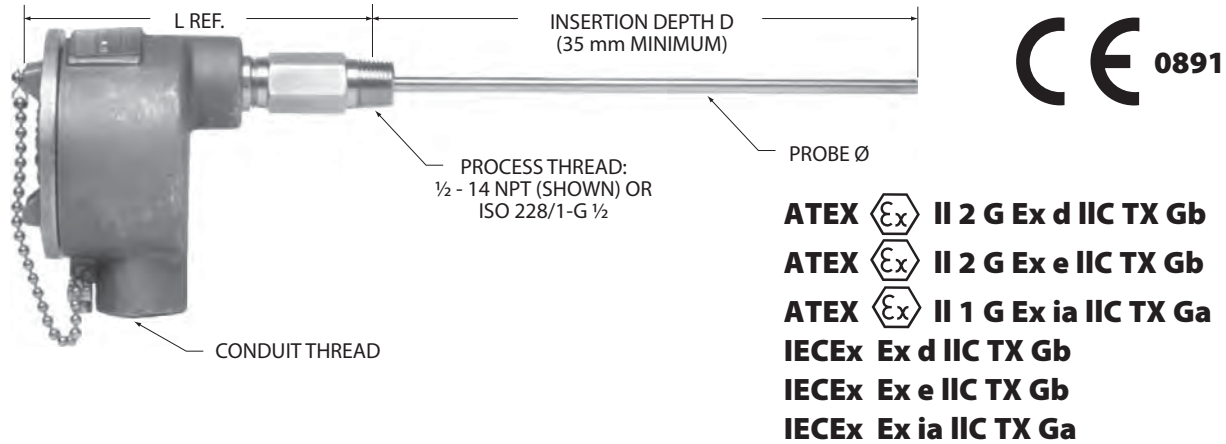

## Overview

Complies with European standards for electrical apparatus for potentially explosive atmospheres: ATEX Directive 94/9/EC and International IECEx certification schemes for explosive atmospheres.

- Flameproof assemblies can be used in Zones 1 or 2
- Increased safety assemblies can be used in Zones 1 or 2
- Intrinsic safety assemblies can be used in Zones 0, 1 or 2 when used with an appropriate barrier
- Features tip-sensitive or MgO filled thermocouple probe for fast response
- Spring-loaded holder ensures good probe contact
- U.S. or metric threads

## Specifications

### Temperature range:

- 50 to 260°C (-58 to 500°F)
- 50 to 600°C (-58 to 1112°F) for MgO Probes

### Material:

- Tip-sensitive probe: Stainless steel with copper alloy tip.
- MgO filled thermocouple: Stainless steel.
- Fittings: Stainless steel.
- Connection head:
  - CH356: 316 stainless steel IP66, Type 3, 4, and 4X.
  - CH357: Aluminum alloy IP65, Type 3 and 4.
  - CH358: Epoxy coated aluminum alloy IP66, Type 3, 4, and 4X.

### Pressure rating:

- Spring-loaded holder: 50 psi (3.4 bar).
- Fluid seal fitting: 100 psi (6.9 bar).

**Insulation resistance:** 100 megohms min. at 100 VDC, leads to probe case. Ungrounded junction models only on thermocouples.

**Connection:** Terminal block for wires up to AWG 14.

**Time constant:** Typical value in moving water.

- Tip sensitive:
  - Single element 1.5 seconds.
  - Dual element 7 seconds.
- All stainless and MgO filled: 10 seconds.

## Temperature Transmitters

Minco's Temptran™ thermocouple transmitters provide a 4 to 20 mA signal or HART® Protocol that can be sent over long distances with a simple 2-wire system. See Section 4 for complete temperature transmitter specifications.

Contact Minco if transmitter is required.

## Hazardous area requirements

For more information on how to classify a hazardous area, methods of protection, and the various standards and agencies (including FM, CSA, IECEx and ATEX), visit [www.minco.com](http://www.minco.com).

▼ = **STANDARD OPTIONS**  
 Specifications subject to change

## Fitting options

Fitting	Process Thread	L REF.		Code	Pressure Rating
		CH356	CH357/CH358		
Fluid Seal	1/2 - 14 NPT		4.6" (116 mm)	0*	50psi (3.4 bar)
Fluid Seal	G 1/2		4.4" (111 mm)	1*	50psi (3.4 bar)
Set screw spring-loaded	1/2 - 14 NPT	5.3" (135 mm)	5.6" (143 mm)	2	50psi (3.4 bar)
Set screw spring-loaded	G 1/2	5.0" (128mm)	5.4" (136 mm)	3	50psi (3.4 bar)
Fixed spring-loaded	1/2 - 14 NPT	4.5" (115 mm)		4	None
Welded	1/2 - 14 NPT	4.2" (107 mm)	4.5" (115 mm)	6**	200psi (13.8 bar)
Welded	G 1/2	4.0" (101 mm)	4.3" (109 mm)	7**	200psi (13.8 bar)
Release knob spring-loaded	1/2 - 14 NPT	5.4" (137 mm)	5.7" (145 mm)	8	50psi (3.4 bar)
Release knob spring-loaded	G 1/2	5.2" (132 mm)	5.5" (140 mm)	9	50psi (3.4 bar)

\* Not available with CH356 stainless steel connection head.

\*\* 0.250" (6.4mm) for MgO only (not available in tip-sensitive or 0.236" diameter models).

## Thermocouple Assembly Numbers

Probe Diameters	0.236" (6.0mm)		0.250" (6.4mm)	
	Single	Dual	Single	Dual
Number of elements	AS806	AS807	AS816	AS817
Tip Sensitive	AS806	AS807	AS816	AS817
MgO	AS808	AS809	AS818	AS819

### Notes:

CH356: 316 stainless steel IP66, Type 3, 4, and 4X.

CH357: Aluminum alloy IP65, Type 3 and 4.

CH358: Epoxy coated aluminum alloy IP66, Type 3, 4, and 4X.

Get more information on connection heads on pages 3-2 to 3-3.

## Junction types

Thermocouple Junction	Code
Chromel-Constantan	E
Iron-Constantan	J
Chromel-Alumel	K
Copper-Constantan	T

## Specification and order options



AS806	Assembly number from table
4	Fitting from table
E	Junction type from table
U	Junction Grounding: G = Grounded U = Ungrounded
450	Insertion depth D (in mm): (35-3000 mm)
P	
3	Conduit thread: 3 = 1/2 - 14 NPT 4 = 3/4 - 14 NPT 5 = M20 x 1.5
A	Connection head material: A = Aluminum S = 316 Stainless Steel E = Aluminum, Epoxy coated
0	Extension: 0 = No Extension 2 = 1/2 NPT Nipple (2")/Union (2.6" length adder) 3 = 1/2 NPT Nipple (3")/Union (3.6" length adder) 4 = 1/2 NPT Nipple (4")/Union (4.6" length adder) 6 = 1/2 NPT Nipple (6")/Union (6.6" length adder)
X0X	No Thermowell
AS8064EU450P3A0X0X= Sample part number	

▼ = STANDARD OPTIONS

Specifications subject to change

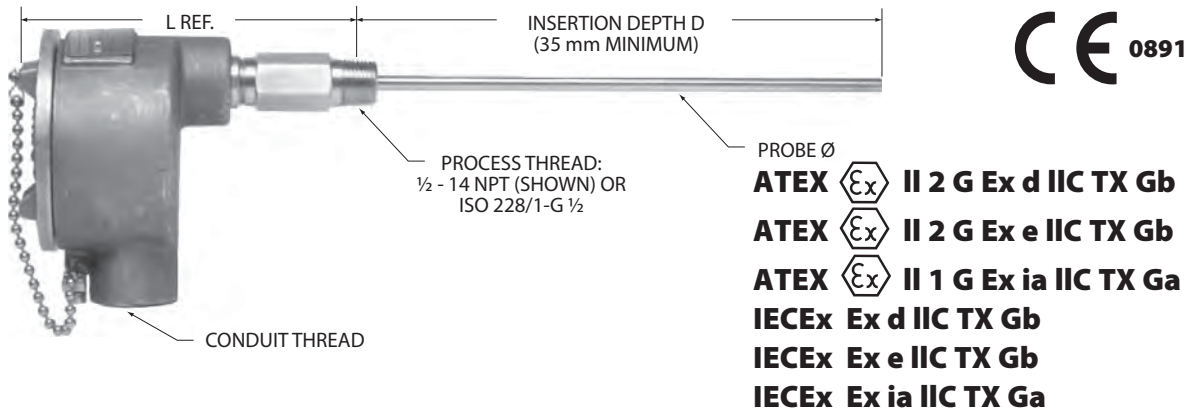
# Flameproof, Increased Safety and Intrinsic Safety RTDs with Transmitters – Per European and International Requirements



- PROBE Ø
- ATEX  II 2 G Ex d IIC TX Gb
  - ATEX  II 2 G Ex e IIC TX Gb
  - ATEX  II 1 G Ex ia IIC TX Ga
  - IECEX Ex d IIC TX Gb
  - IECEX Ex e IIC TX Gb
  - IECEX Ex ia IIC TX Ga

## Overview

Complies with European standards for electrical apparatus for potentially explosive atmospheres: ATEX Directive 94/9/EC and International IECEx certification schemes for explosive atmospheres.

- Flameproof assemblies can be used in Zones 1 or 2
- Increased safety assemblies can be used in Zones 1 or 2
- Intrinsic safety assemblies can be used in Zones 0, 1 or 2 when used with an appropriate barrier
- Features tip-sensitive, all stainless or MgO filled RTD probe for fast response
- Spring-loaded holder ensures good probe contact
- U.S. or metric threads

## Specifications

### Temperature range:

- 50 to 260°C (-58 to 500°F)
- 50 to 600°C (-58 to 1112°F) for MgO Probes

### Material:

- Tip-sensitive probe: Stainless steel with copper alloy tip.
- All stainless RTD: Stainless steel.
- MgO filled RTD: Stainless steel.
- Fittings: Stainless steel.
- Connection head:
  - CH356: 316 stainless steel IP66, Type 3, 4, and 4X.
  - CH357: Aluminum alloy IP65, Type 3 and 4.
  - CH358: Epoxy coated aluminum alloy IP66, Type 3, 4, and 4X.

### Pressure rating:

- Spring-loaded holder: 50 psi (3.4 bar).
- Fluid seal fitting: 100 psi (6.9 bar).

**Insulation resistance:** 100 megohms min. at 100 VDC, leads to probe case.

**Connection:** Terminal block for wires to 14 AWG.

**Time constant:** Typical value in moving water.

Tip sensitive:

- Single element 1.5 seconds.
- All stainless and MgO filled: 10 seconds.

## Temperature Transmitters

Minco's Temptan™ RTD transmitters provide a 4 to 20 mA or HART® Protocol signal that can be sent over long distances with a simple 2-wire system.

### Leadwires:

- 2-lead RTD: TT211, TT520, TT521
- 3-lead RTD: TT520, TT521
- 4-lead RTD: TT520, TT521

**Physical:** Epoxy potted for moisture resistance.

See Section 4 for complete temperature transmitter specifications.

### Hazardous area requirements

For more information on how to classify a hazardous area, methods of protection, and the various standards and agencies (including FM, CSA, IECEx and ATEX), visit [www.minco.com](http://www.minco.com).

▼ = STANDARD OPTIONS  
Specifications subject to change



## Fitting options

Fitting	Process Thread	L REF.		Code	Pressure Rating
		CH356	CH357/CH358		
Fluid Seal	1/2 - 14 NPT		4.6" (116 mm)	0*	50psi (3.4 bar)
Fluid Seal	G 1/2		4.4" (111 mm)	1*	50psi (3.4 bar)
Set screw spring-loaded	1/2 - 14 NPT	5.3" (135 mm)	5.6" (143 mm)	2	50psi (3.4 bar)
Set screw spring-loaded	G 1/2	5.0" (128mm)	5.4" (136 mm)	3	50psi (3.4 bar)
Fixed spring-loaded	1/2 - 14 NPT	4.5" (115 mm)		4	None
Welded	1/2 - 14 NPT	4.2" (107 mm)	4.5" (115 mm)	6**	200psi (13.8 bar)
Welded	G 1/2	4.0" (101 mm)	4.3" (109 mm)	7**	200psi (13.8 bar)
Release knob spring-loaded	1/2 - 14 NPT	5.4" (137 mm)	5.7" (145 mm)	8	50psi (3.4 bar)
Release knob spring-loaded	G 1/2	5.2" (132 mm)	5.5" (140 mm)	9	50psi (3.4 bar)

\* Not available with CH356 stainless steel connection head.

\*\* 0.250" (6.4mm) for all stainless and MgO only

(not available in tip-sensitive or 0.236" diameter models).

## RTD Assembly Numbers

Probe Diameters	0.236" (6.0mm)	0.250" (6.4mm)
Number of elements	Single	Single
Tip Sensitive	AS800	AS810
All Stainless	AS802	AS812
MgO Platinum	AS804	AS814

### Notes:

CH356: 316 stainless steel IP66, Type 3, 4, and 4X.

CH357: Aluminum alloy IP65, Type 3 and 4.

CH358: Epoxy coated aluminum alloy IP66, Type 3, 4, and 4X.

Get more information on connection heads on pages 3-2 to 3-3.

## Temperature transmitter range codes

Popular ranges below. More range codes on pages 4-20 and at [www.minco.com](http://www.minco.com)

Code	Range
EO	-50 to 100°C -58 to 212°F
BC	-30 to 30°C -22 to 86°F
S	-17.8 to 37.8°C 0 to 100°F
AC	-17.8 to 93.3°C 0 to 200°F
AN	-17.8 to 148.9°C 0 to 300°F
AG	-17.8 to 260°C 0 to 500°F
AP	-6.7 to 21.1°C 20 to 70°F
A	-6.7 to 48.9°C 20 to 120°F
N	0 to 50°C 32 to 122°F
C	0 to 100°C 32 to 212°F
J	0 to 150°C 32 to 302°F
K	0 to 200°C 32 to 392°F
V	10 to 65.6°C 50 to 150°F
P	37.8 to 179.4°C 100 to 355°F
BH	50 to 150°C 122 to 302°F

## Sensing elements

RTD sensing element	Code
Platinum (0.00392 TCR) 100 Ω ±0.5% at 0°C	PA
Platinum (0.00385 TCR) 100 Ω ±0.1% at 0°C (Meets EN60751, Class B)	PD
Platinum (0.00385 TCR) 100 Ω ±0.5% at 0°C	PE

## Specification and order options

AS800	Assembly number from table
4	Fitting from table
PD	Sensing element from table
100	Insertion depth D (in mm): (35-3000 mm)
Y	Leads per sensing element: Y = 2 leads (n/a for copper) Z = 3 leads X = 4 leads
3	Conduit thread: 3 = 1/2 - 14 NPT 4 = 3/4 - 14 NPT 5 = M20 x 1.5
A	Connection head material: A = Aluminum S = 316 Stainless Steel E = Aluminum, Epoxy coated
0	Extension: 0 = No Extension 2 = 1/2 NPT Nipple (2")/Union (2.6" length adder) 3 = 1/2 NPT Nipple (3")/Union (3.6" length adder) 4 = 1/2 NPT Nipple (4")/Union (4.6" length adder) 6 = 1/2 NPT Nipple (6")/Union (6.6" length adder)
X0X	No Thermowell
1	Temptran™ code: 1 = TT518: Programmable Hockey Puck (2 or 3-lead RTDs) 2 = TT519: Programmable Hockey Puck (Thermocouple only) 4 = TT211: Fixed range Rectangular (2-lead RTDs) 7 = TT521: HART® Programmable Hockey Puck (2, 3, or 4-lead RTDs or Thermocouples)
N	Temperature range code from table
1	Calibration: 1 = Nominal calibration 2 = Match calibrated, 0.75% total system accuracy. For other calibration options, contact Minco
AS8004PD100Y3A0X0X1N1 = Sample part number	

▼ = STANDARD OPTIONS  
Specifications subject to change

# Eurostyle Sensors

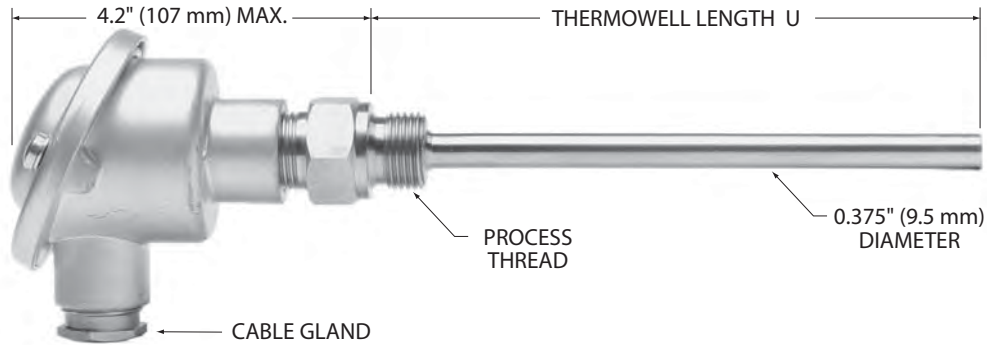

## Overview

These low priced assemblies come complete with thermowells, spring-loaded probes, and connection heads. They provide accurate sensing and quick response in liquid or air streams. Specify U.S. or metric thread for global compatibility.

- Compact, economical RTD or thermocouple assembly
- Metric straight thread or U.S. tapered thread
- Tip-sensitive probe for use to 260°C (500°F)
- Optional European Form B connection head to DIN 43729
- Stainless steel thermowell

## Temperature Transmitters

Minco's Temptran™ RTD transmitters provide a 4 to 20 mA signal or HART® Protocol that can be sent over long distances with a simple 2-wire system. See Section 4 for complete temperature transmitter specifications.

**Special high-accuracy calibration:** For high system accuracy, specify transmitters with matched calibration. Calibration data traceable to NIST will also be provided. Get more information on page 4-22.

## Specifications

**Temperature range:** -50 to 260°C (-58 to 500°F).

### Material:

Probe: Stainless steel with copper alloy tip.

Connection head: Cast aluminum.

Thermowell: 300 series stainless steel.

**Pressure rating:** 2755 psi (190 bar) at 25°C, reducing to 493 psi (34 bar) at 600°C.

**Insulation resistance:** 10 megohms min. at 100 VDC, leads to case. Ungrounded junctions only on thermocouples.

**Connection:** Terminal block for wires to 14 AWG.

**Time constant:** Typical in moving water:

RTD: 35 seconds.

Thermocouple: 27 seconds.

▼ = STANDARD OPTIONS

Specifications subject to change

## Sensing elements

RTD sensing element		Code
Platinum (0.00392 TCR)	100 $\Omega$ $\pm$ 0.5% at 0°C	PA
Platinum (0.00385 TCR) (Meets EN60751, Class B)	100 $\Omega$ $\pm$ 0.1% at 0°C	PD
Platinum (0.00385 TCR)	100 $\Omega$ $\pm$ 0.5% at 0°C	PE
Copper	10 $\Omega$ $\pm$ 0.2% at 25°C	CA
(dual) (0.00427 TCR)	10 $\Omega$ $\pm$ 0.5% at 25°C	CC
Nickel (0.00672 TCR)	120 $\Omega$ $\pm$ 0.5% at 0°C	NA

## RTD specification and order options

AS5240	Assembly number: AS5240: Single element RTD AS5241: Dual element RTD
PD	Sensing element from table
40	TW length U in 0.1" increments [Ex: 40 = 4.0 inches (102 mm)]
Z	Leads per sensing element: Y = 2 leads Z = 3 leads (required for CA/CC) X = 4 leads (single element only)
2	Conduit thread: 1 = 1/2 - 14 NPT 2 = 3/4 - 14 NPT 3 = PG cable gland (Eurostyle only)
A	Connection head: A = Standard aluminum head E = Eurostyle aluminum head
1	TW process thread: 1 = 1/2 - 14 NPT 2 = 3/4 - 14 NPT 3 = ISO 228/1 - G 1/2
To order sensor assembly, stop here. To order with transmitters, add:	
TT520	Temptran™ model: TT520: Programmable (2, 3, & 4-lead RTDs) TT521: HART® Programmable (2, 3, & 4-lead RTDs)
A	Temperature range codes starting on page 4-20 or at <a href="http://www.minco.com">www.minco.com</a>
1	Calibration: 1 = Nominal calibration 2 = Match calibrated, 0.75% total system accuracy. For other calibration options, contact Minco
AS5240PD40Z2A1TT520A1 = Sample part number	

## Thermocouple specification and order options

AS5245	Assembly number: AS5245: Single junction TC AS5246: Dual junction TC
E	Junction type: E = Chromel-Constantan J = Iron-Constantan K = Chromel-Alumel T = Copper-Constantan
G	Junction grounding: G = Grounded U = Ungrounded
135	TW length U in 0.1" increments Specify in 0.1" increments [Ex: 135 = 13.5 inches (343 mm)]
P	
3	Conduit thread: 1 = 1/2 - 14 NPT 2 = 3/4 - 14 NPT 3 = PG cable gland (Eurostyle only)
E	Connection head: A = Standard aluminum head E = Eurostyle aluminum head
3	TW process thread: 1 = 1/2 - 14 NPT 2 = 3/4 - 14 NPT 3 = ISO 228/1 - G 1/2
To order sensor assembly, stop here. To order with transmitters, add:	
TT520	Temptran™ model: 520 = TT520: Programmable, Hockey Puck 521 = TT521: HART® Programmable, Hockey Puck
A	Temperature range codes starting on page 4-20 or at <a href="http://www.minco.com">www.minco.com</a>
AS5245EG135P3E3520A = Sample part number	

▼ = STANDARD OPTIONS

Specifications subject to change

# Specifying Custom Assemblies

The standard assemblies in this section will fit a wide variety of installations. However, for more versatility you can create new assemblies from the probes, accessories, and transmitters in the pages listed.

## Follow these steps:

### 1. Choose a probe

Select an RTD or thermocouple from Section 2. The section includes tip-sensitive, high temperature, and fast response models. Some have integral fittings or bayonet lockcaps.

Factors to consider are:

- Temperature rating
- Compatibility with receiving instruments
- Probe style and diameter
- Accuracy vs. cost

### 2. Add a fitting

See Section 3 for probe mounting fittings. Adjustable fittings, combined with cut-to-length probes, allow instant fabrication of assemblies to any length required. Included are spring-loaded holders, pressure fittings, and bayonet-style fittings.

Factors to consider are:

- Temperature rating
- Probe diameter
- Correct NPT threads
- Pressure ratings
- Compatibility with environment

### 3. Select a thermowell

Thermowells protect sensors from the effects of fluid flow and pressure. See Section 3 for a variety of well styles and materials.

Factors to consider are:

- Pressure rating
- Compatibility with fluid media
- Insertion depth
- Correct NPT thread

### 4. Attach a connection head

Finish off your assembly with a connection head for termination to remote extension wires. See page 3-2 for specifications.

Factors to consider are:

- Connection head size
- Temperature rating
- Correct pipe threads for fitting and conduit
- Number of terminals or wire nuts
- Hazardous area requirements

### 5. Install a transmitter

Transmitters convert sensor output to a 4 to 20 mA current signal, immune to leadwire resistance. See Section 4 for RTD and thermocouple transmitters.

Factors to consider are:

- Transmitter accepts sensor input
- Transmitter fits connection head
- Ambient temperature range acceptable

### 6. How to calculate probe length

All Minco fittings have probe length adders to help you determine total probe length. Total length  $L$  is the insertion depth  $D$  plus the adder  $A$ .

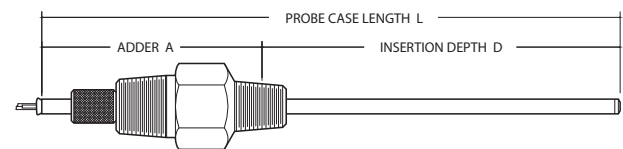

Thermowell drawings show an adder to convert thermowell length  $U$  to insertion depth  $D$ . Then use  $D$  plus the fitting adder  $A$  to find total probe length  $L$ .

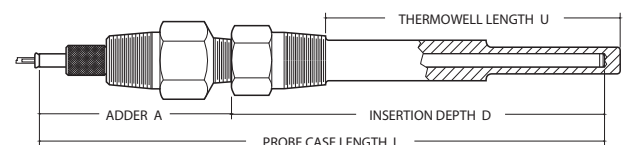

▼ = STANDARD OPTIONS  
Specifications subject to change



## ▶ SECTION 2: PROBES

- RTDs and thermocouples in a variety of configurations for easy installation
- Tip-sensitive and fast response probes for quick and accurate temperature sensing
- High temperature probes to 650°C for extreme environments
- Single and dual elements offer high reliability
- Cut-to-length models are marked with  (see page 2-18 for instructions)

Tip-sensitive RTDs and thermocouples.....	2-2 to 2-3
Fast Response RTDs.....	2-4 to 2-5
Bayonet mount tip-sensitive RTDs, thermocouples.....	2-6 to 2-7
Electrically isolated RTDs, thermocouples.....	2-8 to 2-9
550°C RTDs, thermocouples.....	2-10 to 2-11
600°C RTDs.....	2-12

Mineral-insulated RTDs.....	2-13
Compact plug sensor.....	2-14
Integrated sensor transmitter.....	2-15
Conductivity level sensor.....	2-16 to 2-17
How to shorten cut-to-length probes.....	2-18
PFA, FEP encapsulation.....	2-18

# Tip-sensitive RTDs & Thermocouples

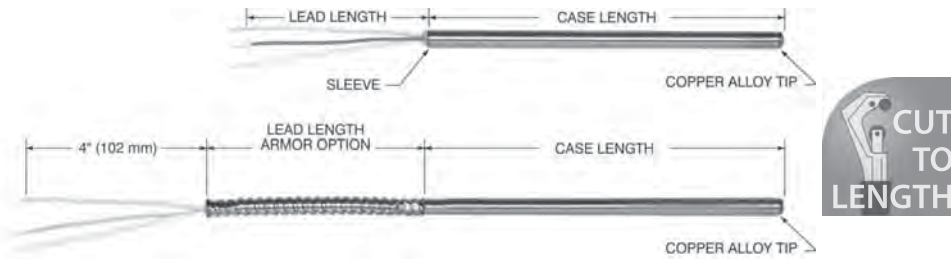

## Overview

The probe sensing tip is constructed of copper alloy which is twenty times more conductive than stainless steel. The sensors react more quickly to changes and indicate tip temperature instead of stem temperature. The result is better accuracy in thermowells, bearings, and other installations. Minco recommends 0.250" diameter probes for use in thermowells.

- Copper alloy tip for fast response
- Accurate sensing to 260°C (500°F)
- Non-armor models can be user-shortened

## Specifications

### Temperature range:

**Thermocouple:** -184 to 260°C (-300 to 500°F).

**RTD:** -50 to 260°C (-58 to 500°F).

### Case:

Stainless steel with copper alloy tip.

### Minimum case length:

**Thermocouple:** 2.5" (63.5 mm).

- RTD:**
- Single element probes: 2.8" (71.1 mm).
  - Dual element probes: 4.0" (101.6 mm).

### Maximum case length:

48" (1220 mm), longer on special order.

### Leads:

**Thermocouple:** Solid thermocouple wire, AWG 20 (except AWG 24 on model TC355). Specify PTFE insulation, stainless steel overbraid, or stainless steel armor.

**RTD:** 2, 3, or 4 leadwires, stranded copper with PTFE insulation. AWG 22, except 0.188" diameter dual probes AWG 24. For 2-lead RTDs add 0.03 Ω per foot (0.05 Ω per foot for 0.188" diameter dual probes) of combined case and lead length to element tolerance. Copper (CA, CC) models must have 3 leads.

### Time constant:

**Thermocouple:** Typical value in moving water:

- Grounded junction: 1.5 seconds.
- Ungrounded junction: 7 seconds.

### RTD:

- 2.0 seconds typical in moving water.
- 3.0 seconds for dual element models.

### Pressure rating:

100 psi (6.9 bar).

## Insulation resistance:

**Thermocouple:** 10 megohms minimum at 100 VDC, leads to case, ungrounded junctions only.

### RTD:

- Single element probes: 1000 megohms min. at 500 VDC, leads to case.
- Dual element probes: 100 megohms min. at 100 VDC, between elements and leads to case.

## Vibration:

Withstands 10 to 2000 Hz at 20 G's min. per MIL-STD-202, Method 204, Test Condition D.

## Shock:

Withstands 100 G's min. sine wave shock of 8 milliseconds duration.

## Model numbers: Thermocouples

	Model for probe diameter:		
	0.188" (4.8 mm)	0.215" (5.5 mm)	0.250" (6.4 mm)
Single junction	▼ TC354	▼ TC356	▼ TC358
Dual junction	▼ TC355	▼ TC357	▼ TC359

## Specification and order options: Thermocouples

TC356	Model number from table
T	<b>Junction type:</b> ▼ E = Chromel-Constantan ▼ J = Iron-Constantan ▼ K = Chromel-Alumel ▼ T = Copper-Constantan
G	<b>Junction grounding:</b> ▼ G = Grounded ▼ U = Ungrounded
120	<b>Case length:</b> Specify in 0.1" increments: Ex: 120 = 12.0 inches ▼ : 60, 120, 240
T	<b>Covering over leadwires:</b> ▼ T = PTFE only G = Glass braid only S = Stainless steel overbraid A = Stainless steel armor
80	Lead length in inches: ▼80
TC356TG120T80 = Sample part number	

▼ = STANDARD OPTIONS

Specifications subject to change

**Model numbers: RTD's**

Element	Model for probe diameter:		
	0.188" (4.8 mm)	0.215" (5.5 mm)	0.250" (6.4 mm)
<b>Single element RTDs: No armor over leads</b>			
Platinum (0.00392 TCR) 100 Ω ±0.5% at 0°C	▼S54PA	▼S51PA	▼S53PA
Platinum (0.00385 TCR) 100 Ω ±0.06% at 0°C (Meets EN60751, Class A)	▼S554PM	▼S551PM	▼S553PM
Platinum (0.00385 TCR) 100 Ω ±0.1% at 0°C (Meets EN60751, Class B)	▼S854PD	▼S851PD	▼S853PD
Platinum (0.00385 TCR) 100 Ω ±0.5% at 0°C	S884PE	S881PE	S883PE
Copper (0.00427 TCR) 10 Ω ±0.2% at 25°C	S54CA	S51CA	S53CA
Nickel (0.00672) 120 Ω ±0.5% at 0°C	S54NA	S51NA	S53NA
<b>Single element RTDs: With armor over leads</b>			
Add element code (Ex: S154__ =S154NA)	▼S154__	▼S151__	▼S153__
<b>Dual element RTDs: No armor over leads</b>			
Platinum (0.00392 TCR) 100 Ω ±0.5% at 0°C	▼S59PA	▼S56PA	▼S57PA
Platinum (0.00385 TCR) 100 Ω ±0.06% at 0°C (Meets EN60751, Class A)	S559PM	S856PM	S557PM
Platinum (0.00385 TCR) 100 Ω ±0.1% at 0°C (Meets EN60751, Class B)	▼S859PD	▼S856PD	▼S857PD
Platinum (0.00385 TCR) 100 Ω ±0.5% at 0°C	S889PE	S886PE	S887PE
Copper (0.00427 TCR) 10 Ω ±0.5% at 25°C		S56CC	S57CC
Nickel (0.00672) 120 Ω ±0.5% at 0°C	S59NA	S56NA	S57NA
<b>Dual element RTDs: With armor over leads</b>			
Add element code (Ex: S159__ =S159NA)	S159__	S156__	▼S157__



**STOCKED PARTS AVAILABLE**

**Specification and order options: RTD's**

S59PA	Model number from table
120	Case length: Specify in 0.1" increments (Ex: 120 = 12.0 inches) ▼ : 40, 50, 60, 70, 80, 90, 100, 110, 120, 140, 160, 180, 200, 240
Z	# of leads per sensing element: Y = 2 leads ▼ Z = 3 leads (req'd for copper elements) ▼ X = 4 leads (PD only)
36	Lead length in inches ▼ : 36, 80, 120
S59PA120Z36 = Sample part number	

Minco also offers probes equivalent to those shown on this page with the added certifications of:

- ATEX Ex ia and EX e (Zones 0 and 1)
- IECEx Ex ia and EX e (Zones 0 and 1)
- TR CU (EAC) Ex ia and EX e (Zones 0 and 1)

▼ = **STANDARD OPTIONS**

*Specifications subject to change*



# Fast Response RTDs

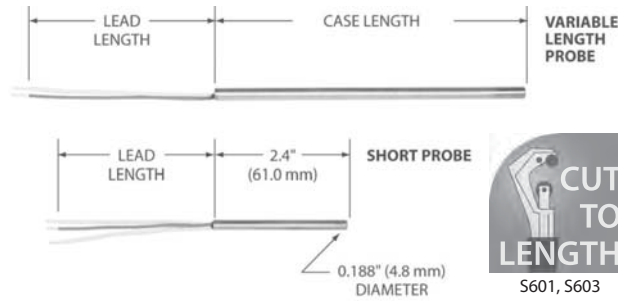

## Overview

These probes have rugged stainless steel cases for use in high pressures or corrosive fluids. Yet their time constants are comparable to copper-tipped probes at 2 to 4 seconds, compared to 8 to 10 seconds for other all-stainless probes.

- Unique low-mass element reacts quickly to temperature changes
- Non-armor models can be user-shortened
- ATEX, IECEx and TR CU (EAC) Ex e and Ex ia options available

## Specifications

**Temperature range:** -269 to 260°C (-452 to 500°F).

### Case material:

S601, S603, S604: 316 stainless steel.

S602, S614: 304/305 stainless steel.

### Case length:

Minimum case length:

S602, S604: 2.0" (50.8 mm) with PTFE insulated leads;  
3.0" (76.2 mm) with SS braid over leads.

S601, S603: 3.0" (76.2 mm).

Maximum case length:

48" (1220 mm), longer on special order.

**Time constant:** Typical in moving water:

S602, S604, S614: 2 seconds.

S601: 3 seconds.

S603: 4 seconds.

**Pressure rating:** 1500 psi (103 bar).

**Leads:** 2, 3, or 4 leadwires, AWG 22, stranded copper with PTFE insulation, stainless steel braid, or stainless steel armor.

For 2-lead RTDs add 0.03 Ω per foot of combined case and lead length to element tolerance (model S602 has AWG 26; add 0.08 Ω per foot for 2-lead).

**Insulation resistance:** 1000 megohms minimum at 500 VDC, leads to case.

**Vibration:** Withstands 10 to 2000 Hz at 20 G's minimum per MIL-STD-202, Method 204, Test Condition D.

**Shock:** Withstands 100 G's minimum sine wave shock of 8 milliseconds duration.

## Sensing elements

RTD sensing element		Code
Platinum (0.00392 TCR)	100 Ω ±0.5% at 0°C	▼ PA
Platinum (0.00385 TCR) (Meets EN60751, Class B)	100 Ω ±0.1% at 0°C	▼ PD
Platinum (0.00385 TCR)	100 Ω ±0.5% at 0°C	PE
Platinum (0.00385 TCR) (N/A for model S602)	1000 Ω ±0.1% at 0°C	▼ PF
Copper (0.00427 TCR)	10 Ω ±0.2% at 25°C	CA
Nickel (0.00672 TCR)	120 Ω ±0.5% at 0°C	NA

## Specification and order options:

### Fast response probes

Specify 0.125" or 0.188" for fastest response, 0.250" or 0.215" for greater strength and cut-to-length capability (PTFE and SS braid models).

S604	<b>Model number:</b> ▼ S601: Ø 0.215" (5.5 mm) Cut-to-length probe ▼ S602: Ø 0.125" (3.2 mm) ▼ S603: Ø 0.250" (6.4 mm) Cut-to-length probe ▼ S604: Ø 0.188" (4.8 mm)
PD	<b>Sensing element from table</b> ▼: PA, PD, PF
240	<b>Case length:</b> Specify in 0.1" increments (Ex: 240 = 24.0 inches) ▼: 30, 40, 60, 90, 120, 240
X	<b>Number of leadwires:</b> Y = 2 leads ▼ Z = 3 leads (required for copper elements) ▼ X = 4 leads (PD only)
36	<b>Lead length in inches</b> ▼: 36, 120
T	<b>Covering over leadwires:</b> (S, A not available on S602) ▼ T = PTFE only ▼ S = Stainless steel braid A = Stainless steel armor
S604PD240X36T = Sample part number	

### Short probes

▼ S614	<b>Model number (case with fixed length of 2.4" (61 mm))</b>
PA	<b>Sensing element from table</b> ▼: PA, PD, PF
Z	<b>Number of leadwires:</b> Y = 2 leads ▼ Z = 3 leads (required for copper elements) X = 4 leads (PD only)
36	<b>Lead length in inches</b> ▼ 36
T	<b>Covering over leadwires:</b> ▼ T = PTFE only S = Stainless steel braid
S614PAZ36T = Sample part number	



**STOCKED PARTS AVAILABLE**

Specifications subject to change



# Fast Response Immersion RTDs

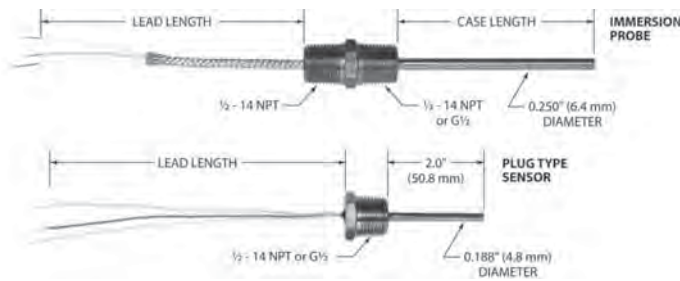

## Overview

You can mount these probes directly in fluid streams for accurate, reliable sensing. Time constant is just 2 seconds, compared to 10 seconds for an ordinary stainless probe or up to 50 seconds for a thermowell. The result is more accurate monitoring of dynamic processes.

- Pressure rating 1500 psi (103 bar)
- Quick reaction to changing fluid and gas temperatures
- NPT (U.S.) or metric threads
- ATEX, IECEx and TR CU (EAC) Ex e and Ex ia options available

## Specifications

**Temperature range:** -269 to 260°C (-452 to 500°F).

### Case material:

S623, S628: 316 stainless steel.

S634, S639: 304/305 stainless steel.

### Case length:

Minimum case length: 1.5" (38.1 mm).

Maximum case length: 48" (1220 mm), longer on special order.

**Time constant:** Typical value in moving water:

S623, S628: 4 seconds.

S634, S639: 2 seconds.

**Pressure rating:** 1500 psi (103 bar).

**Leads:** 2, 3, or 4 leadwires, AWG 22, stranded copper with PTFE insulation, stainless steel braid, or stainless steel armor.

For 2-lead RTDs add 0.03 Ω per foot of combined case and lead length to element tolerance.

**Insulation resistance:** 1000 megohms minimum at 500 VDC, leads to case.

**Vibration:** Withstands 10 to 2000 Hz at 20 G's minimum per MIL-STD-202, Method 204, Test Condition D.

**Shock:** Withstands 100 G's minimum sine wave shock of 8 milliseconds duration.

## Sensing elements

RTD sensing element		Code
Platinum (0.00392 TCR)	100 Ω ±0.5% at 0°C	PA
Platinum (0.00385 TCR)	100 Ω ±0.1% at 0°C (Meets EN60751, Class B)	▼PD
Platinum (0.00385 TCR)	100 Ω ±0.5% at 0°C	PE
Platinum (0.00385 TCR)	1000 Ω ±0.1% at 0°C (N/A for model S602)	▼PF
Copper (0.00427 TCR)	10 Ω ±0.2% at 25°C	CA
Nickel (0.00672 TCR)	120 Ω ±0.5% at 0°C	NA

## Specification and order options:

### Immersion probes

These probes have welded fittings to mount directly into fluid vessels. Add a connection head for termination of extension leads.

S623	<b>Model number:</b> ▼S623: 1/2 - 14 NPT thread [2] S628: ISO 228/1-G1/2 process thread (1/2 - 14 NPT on leads end)
PF	<b>Sensing element from table</b> ▼: PD, PF
60	<b>Case length:</b> Specify in 0.1" increments (Ex: 60 = 6.0 inches) ▼: 20, 60, 120
Z	<b>Number of leads:</b> Y = 2 leads    X = 4 leads (PD only) ▼Z = 3 leads (required for copper elements)
72	<b>Lead length in inches</b> ▼: 72
T	<b>Covering over leadwires:</b> ▼T = PTFE only    A = Stainless steel armor S = Stainless steel braid
S623PF60Z72T = Sample part number	

### Plug type sensors

Save space and get accurate readings with this compact, easy-to-install probe.

S634	<b>Model number:</b> S634: 1/2 - 14 NPT thread S639: ISO 228/1-G1/2 thread
NA	<b>Sensing element from table</b>
Y	<b>Number of leads:</b> Y = 2 leads    X = 4 leads (PD only) Z = 3 leads (required for copper elements)
24	<b>Lead length in inches</b>
T	<b>Covering over leadwires:</b> T = PTFE only    S = Stainless steel braid
S634NAY24T = Sample part number	



**STOCKED PARTS AVAILABLE**

Specifications subject to change



# Bayonet Mount Tip-sensitive RTDs

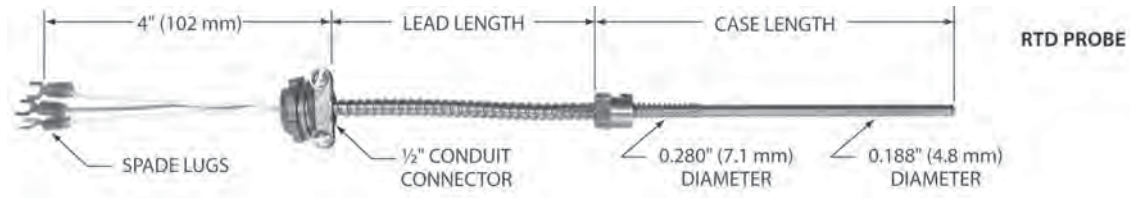

## Overview

Bayonet mounting provides easy and inexpensive spring-loaded installation of probes into solids. All models have a copper alloy tip for fast time response and increased tip sensitivity.

See page 3-9 for bayonet fittings or page 3-10 for metric fittings.

- Lockcap and spring for twist-and-release spring-loading
- Accurate sensing to 260°C (500°F)
- ATEX, IECEx and TR CU (EAC) Ex e and Ex ia options available

## Specifications

**Temperature range:** -50 to 260°C (-58 to 500°F).

**Case:** Stainless steel with copper alloy tip.

Minimum case length: 3.0" (76.2 mm).

Maximum case length: 48" (1220 mm), longer on special order.

**Time constant:** 2 seconds typical in moving water.

**Leads:** 2, 3, or 4 leadwires, AWG 22, stranded copper with PTFE insulation, stainless steel armor, and 1/2" conduit connector. For 2-lead RTDs add 0.03 Ω per foot of combined case and lead length to element tolerance.

**Insulation resistance:** 1000 megohms min. at 500 VDC, leads to case.

**Vibration:** Withstands 10 to 2000 Hz at 20 G's minimum per MIL-STD-202, Method 204, Test Condition D.

**Shock:** Withstands 100 G's minimum sine wave shock of 8 milliseconds duration.

## Model numbers

RTD sensing element		Model
Platinum (0.00392 TCR)	100 Ω ±0.5% at 0°C	▼S44PA
Platinum (0.00385 TCR)	100 Ω ±0.1% at 0°C (Meets EN60751, Class B)	▼S844PD
Platinum (0.00385 TCR)	100 Ω ±0.5% at 0°C	S874PE
Copper (0.00427 TCR)	10 Ω ±0.2% at 25°C	S44CA
Nickel (0.00672 TCR)	120 Ω ±0.5% at 0°C	▼S44NA

## Specification and order options

S44PA	Model number from table
120	Case length: Specify in 0.1" increments (Ex: 120 = 12.0 inches) ▼: 49, 55, 120
Z	Number of leads: Y = 2 leads ▼Z = 3 leads (required for copper elements) X = 4 leads (PD only)
80	Lead length in inches ▼: 80
S44PA120Z80 = Sample part number	

▼ = STANDARD OPTIONS

Specifications subject to change

# Bayonet Mount Tip-sensitive Thermocouples

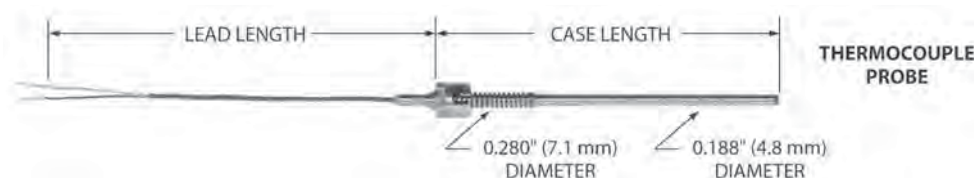

## Overview

Bayonet mounting provides easy and inexpensive spring-loaded installation of probes into solids. All models have a copper alloy tip for fast time response and increased tip sensitivity.

See page 3-9 for bayonet fittings or page 3-10 for metric fittings.

- Lockcap and spring for twist-and-release spring-loading
- Accurate sensing to 260°C (500°F)
- ATEX, IECEx and TR CU (EAC) Ex e and Ex ia options available

## Specifications

**Temperature range:** -50 to 260°C (-58 to 500°F).

**Case:** Stainless steel with copper alloy tip.

Minimum case length: 3.0" (76.2 mm).

Maximum case length: 48" (1220 mm), longer on special order.

**Leads:** Solid thermocouple wire, AWG 20 (single) or AWG 24 (dual). Specify PTFE insulation, glass braid insulation, stainless steel braid over glass braid, or stainless steel armor over PTFE.

**Time constant:** Typical value in moving water:

Grounded junction: 1.5 seconds.

Ungrounded junction: 7 seconds.

**Insulation resistance:** 10 megohms minimum at 100 VDC, leads to case, ungrounded junctions only.

**Vibration:** Withstands 10 to 2000 Hz at 20 G's minimum per MIL-STD-202, Method 204, Test Condition D.

**Shock:** Withstands 100 G's minimum sine wave shock of 8 milliseconds duration.

## Specification and order options

TC360	<b>Model number:</b> ▼TC360 = Single junction ▼TC361 = Dual junction
J	<b>Junction type:</b> E = Chromel-Constantan ▼J = Iron-Constantan ▼K = Chromel-Alumel T = Copper-Constantan
G	<b>Junction grounding:</b> ▼G = Grounded ▼U = Ungrounded
30	<b>Case length:</b> Specify in 0.1" increments (Ex: 95 = 9.5 inches) ▼: 30, 120
A	<b>Covering over leadwires:</b> T = PTFE only G = Glass braid ▼A = Stainless steel armor S = Stainless steel overbraid
120	<b>Lead length in inches</b> ▼: 120
TC360JG30A120 = Sample part number	

▼ = STANDARD OPTIONS  
Specifications subject to change

# Electrically Isolated RTDs

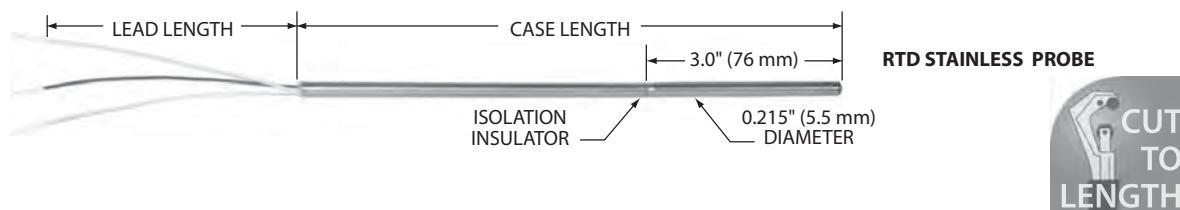

## Overview

- Electrically isolated sensing tip for “hot” bearings
- Accurate sensing to 260°C (500°F)
- Copper alloy tip for fast time response and increased tip sensitivity
- ATEX, IECEx and TR CU (EAC) Ex e and Ex ia options available

## Specifications

**Dielectric strength of isolation insulator:** 1000 volts RMS at 60 Hz for 30 seconds, between case sections, 1 mA max. leakage current.

**Pressure rating:** 30 psi (2.1 bar).

**Vibration:** Withstands 10 to 2000 Hz at 20 G’s minimum per MIL-STD-202, Method 204, Test Condition D.

**Shock:** Withstands 100 G’s minimum sine wave shock of 8 milliseconds duration.

## Isolated tip RTDs

RTD sensing element		Model
Platinum (0.00392 TCR)	100 Ω ±0.5% at 0°C	▼ S52PA
Platinum (0.00385 TCR) (Meets EN60751, Class B)	100 Ω ±0.1% at 0°C	▼ S852PD
Platinum (0.00385 TCR)	100 Ω ±0.5% at 0°C	S882PE
Copper (0.00427 TCR)	10 Ω ±0.2% at 25°C	S52CA
Nickel (0.00672 TCR)	120 Ω ±0.5% at 0°C	S52NA

**Temperature Range:** -50 to 260°C (-58 to 500°F).

**Case:** Stainless steel with copper alloy tip.

Minimum case length: 4.0" (101.6 mm).

Maximum case length: 48" (1220 mm), longer on special order.

**Leads:** 2, 3, or 4 leadwires, AWG 22, stranded copper with PTFE insulation. For 2-lead RTDs add 0.03 Ω per foot of combined case and lead length to element tolerance.

**Time constant:** 2 seconds typical in moving water.

**Insulation resistance:** 1000 megohms min. at 500 VDC, leads to case.

## Specification and order options

S52PA	Model number from isolated tip table
240	Case length: Specify in 0.1" increments (Ex: 240 = 24.0 inches) ▼: 120, 180, 240
Z	Number of leads: Y = 2 leads ▼ Z = 3 leads (required for copper elements) X = 4 leads (PD only)
36	Lead length in inches ▼: 36, 120
S52PA240Z36 = Sample part number	



**STOCKED PARTS AVAILABLE**

▼ = **STANDARD OPTIONS**

Specifications subject to change

# Electrically Isolated Thermocouples

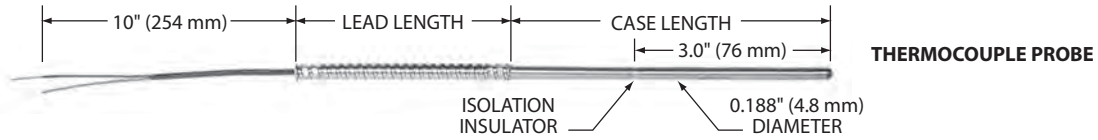

## Overview

- Electrically isolated sensing tip for “hot” bearings
- Accurate sensing to 260°C (500°F)
- Copper alloy tip for fast time response and increased tip sensitivity
- ATEX, IECEx and TR CU (EAC) Ex e and Ex ia options available

**Time constant:** Typical value in moving water:

Grounded junction: 1.5 seconds.

Ungrounded junction: 7 seconds.

**Insulation resistance:** 10 megohms min. at 100 VDC, leads to case, ungrounded junctions only.

## Specifications

**Dielectric strength of isolation insulator:** 1000 volts RMS at 60 Hz for 30 seconds, between case sections, 1 mA max. leakage current.

**Pressure rating:** 30 psi (2.1 bar).

**Vibration:** Withstands 10 to 2000 Hz at 20 G’s minimum per MIL-STD-202, Method 204, Test Condition D.

**Shock:** Withstands 100 G’s minimum sine wave shock of 8 milliseconds duration.

**Temperature Range:** -50 to 260°C (-58 to 500°F).

**Case:** Stainless steel with copper alloy tip.

Minimum case length: 4.0” (101.6 mm).

Maximum case length: 48” (1220 mm), longer on special order.

**Leads:** Solid thermocouple wire, AWG 20 (AWG 24 for stainless steel braid option). Specify PTFE insulation or PTFE with stainless steel armor and shrink tubing over all.

## Specification and order options

TC2198	Model number: TC2198
J	<b>Junction type:</b> E = Chromel-Constantan ▼ J = Iron-Constantan ▼ K = Chromel-Alumel T = Copper-Constantan
U	<b>Junction grounding:</b> ▼ G = Grounded ▼ U = Ungrounded
60	<b>Case length:</b> Specify in 0.1” increments (Ex: 60 = 6.0 inches) ▼ : 60, 120
T	<b>Covering over leadwires:</b> ▼ T = PTFE only ▼ A = Stainless steel armor plus shrink tubing S = SS braid over PTFE (5” min. case length)
120	<b>Lead length in inches</b> ▼ : 120
TC2198JU60T120 = Sample part number	

▼ = STANDARD OPTIONS

Specifications subject to change

# 550°C RTD Probes

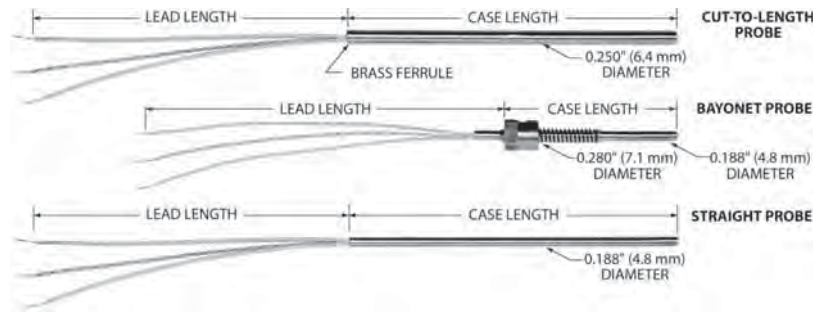

## Overview

Install these probes in steam lines, exhaust gases, or wherever you need precise readings of elevated temperatures. RTD probes feature high temperature ceramic elements, assembled into stainless steel cases in a configuration that provides long-term reliable service.

Models S80 and S81 can be shortened by the user. You can stock standard lengths and cut them to the size required with an ordinary tubing cutter.

Bayonet-style probes have a lockcap and spring for spring-loaded installation. See page 3-9 for more information on bayonet fittings.

- 0.250" diameter cut-to-length RTDs
- 0.188" diameter straight and bayonet RTDs

## Specifications

### Temperature range:

-100 to 550°C (-148 to 1022°F).

Leadwires: 500°C (932°F) max.

**Case:** 316 stainless steel.

Minimum case length:

0.250" diameter: S80, S81: 4.0" (101.6 mm).

0.188" diameter: S71, S72: 2.0" (50.8 mm)  
S73, S74: 3.0" (76.2 mm).

Maximum case length: 48" (1220 mm), longer on special order.

**Pressure rating:** 1500 psi (103 bar).

**Vibration:** Withstands 10 to 2000 Hz at 20 G's minimum per MIL-STD-202, Method 204, Test Condition D.

**Shock:** Withstands 100 G's minimum sine wave shock of 8 milliseconds duration.

**Leads:** 2 or 3 leadwires, AWG 22, stranded copper with mica/glass insulation. For 2-lead RTDs add 0.04 Ω per foot of combined case and lead length to element tolerance.

**Time constant:** 10 seconds typical in moving water.

**Insulation resistance:** 10 megohms min. at 100 VDC, leads to case.

### Model numbers:

**Straight probe: Ø 0.188" (4.8 mm)**

Element		Model
Platinum (0.00391 TCR)	100 Ω ±0.1% at 0°C	S71PB
Platinum (0.00385 TCR)*	100 Ω ±0.1% at 0°C	▼S72PD

**Bayonet probe: Ø 0.188" (4.8 mm)**

Element		Model
Platinum (0.00391 TCR)	100 Ω ±0.1% at 0°C	▼S73PB
Platinum (0.00385 TCR)*	100 Ω ±0.1% at 0°C	▼S74PD

**Cut-to-length: Ø 0.250" (6.4 mm)**

Element		Model
Platinum (0.00391 TCR)	100 Ω ±0.1% at 0°C	▼S80PB
Platinum (0.00385 TCR)*	100 Ω ±0.1% at 0°C	▼S81PD

\*Meets EN60751, Class B

## Specification and order options

S74PD	Model number from table
240	Case length: Specify in 0.1" increments (Ex: 240 = 24.0 inches) ▼: 20, 30, 120, 240
Z	Number of leads: Y = 2 leads ▼Z = 3 leads
36	Lead length in inches ▼: 36, 120
S74PD240Z36 = Sample part number	



**STOCKED PARTS AVAILABLE**

▼ = **STANDARD OPTIONS**  
Specifications subject to change

# 550°C Thermocouple Probes

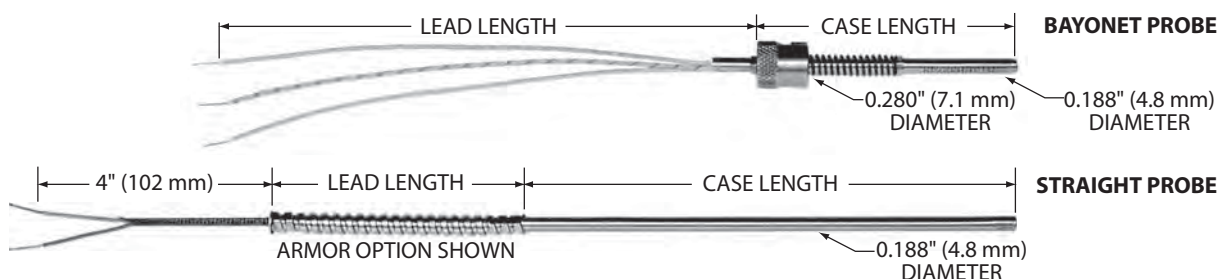

## Overview

Install these probes in steam lines, exhaust gases, or wherever you need precise readings of elevated temperatures.

Bayonet-style probes have a lockcap and spring for spring-loaded installation. See page 3-9 for more information on bayonet fittings.

## Specifications

### Temperature range:

-100 to 550°C (-148 to 1022°F).

Leadwires: 500°C (932°F) max.

**Case:** 316 stainless steel.

Minimum case length: 2.5" (63.5 mm)

Maximum case length: 48" (1220 mm), longer on special order.

**Pressure rating:** 1500 psi (103 bar).

**Vibration:** Withstands 10 to 2000 Hz at 20 G's minimum per MIL-STD-202, Method 204, Test Condition D.

**Shock:** Withstands 100 G's minimum sine wave shock of 8 milliseconds duration.

**Leads:** Solid thermocouple wire, AWG 20. Specify glass braid insulation, stainless steel overbraid, or stainless steel armor.

**Time constant:** 7 seconds typical in moving water.

**Insulation resistance:** 10 megohms minimum at 100 VDC, leads to case, ungrounded junctions only.

## Specification and order options

TC173	<b>Model number:</b> ▼TC173: Straight probe ▼TC171: Bayonet mount
E	<b>Junction type:</b> ▼E = Chromel-Constantan J = Iron-Constantan ▼K = Chromel-Alumel T = Copper-Constantan
U	<b>Junction grounding:</b> ▼G = Grounded ▼U = Ungrounded
60	<b>Case length:</b> Specify in 0.1" increments (Ex: 45 = 4.5 inches) ▼: 30, 60, 120, 180
G	<b>Covering over leadwires:</b> ▼G = Glass braid only ▼S = Stainless steel overbraid A = Stainless steel armor
120	<b>Lead length in inches</b> ▼: 120
TC173EU60G120 = Sample part number	

▼ = STANDARD OPTIONS

Specifications subject to change

# 600°C RTDs

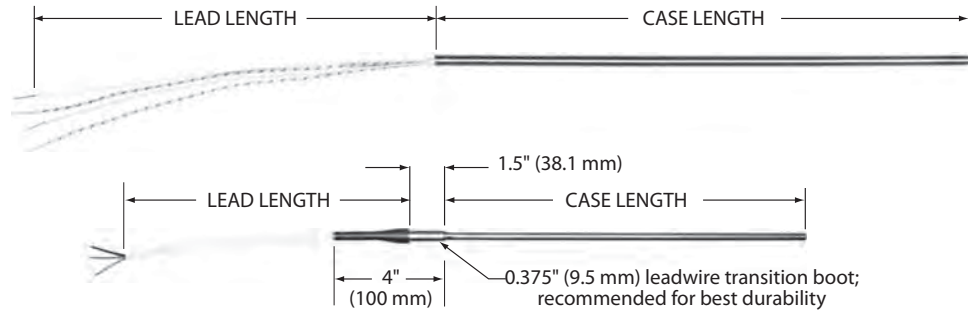

## Overview

These RTDs cover the full temperature scale of the international standard EN60751. Precision sensing elements are capable of measurements from -200 to 600°C (-328 to 1112°F) with typical ice point drift less than  $\pm 0.05^\circ\text{C}$ .

- Platinum elements to EN60751, Class A or B
- English and metric diameters

## Specifications

**Element:** Platinum, 100  $\Omega$  at 0°C, TCR = 0.00385  $\Omega/\Omega/^\circ\text{C}$ .

**Temperature range:** -200 to 600°C (-328 to 1112°F). Reduced temperature rating for leads and last 2" (50 mm) of case — see leadwire chart.

**Case:** 316 stainless steel.

Minimum case length: 2.0" (50.8 mm).

Maximum case length: 48.0" (1220 mm), longer on special order.

Probe diameter	Model
0.188" (4.8 mm)	▼S914
0.236" (6.0 mm)	▼S912
0.250" (6.4 mm)	▼S913

**Tolerance:** EN60751 Class A or B.

Class A:  $\pm 0.06\%$

Class B:  $\pm 0.12\%$

**Repeatability:** Meet IEC requirements. Typical shift less than 0.05°C (0.02  $\Omega$ ) at 0°C after ten cycles over range.

**Stability:** Meet IEC stability specifications after 250 hours exposure to extremes of temperature range. Typical drift is less than 0.05°C (0.02  $\Omega$ ) at 0°C.

**Vibration:** Will withstand 10 to 5000 Hz at 2 G's minimum per EN60751.

**Shock:** Will withstand 250 mm drop onto 8 mm thick steel plate (approximately 1400 G's for 0.08 ms).

**Time constant:** 10 seconds typical in moving water.

**Pressure rating:** 1000 psi (69 bar) at 25°C.

**Insulation resistance:** 10 megohms minimum at 100 VDC, leads to case.

## Leadwire options:

Code	Description	Max. temp.*
▼G	Mica/glass insulated stranded copper, AWG 22.	600°C 1112°F
T	PTFE insulated stranded copper, AWG 22.	260°C 500°F
C	AWG 24, PTFE insulated, stranded copper wires with silver-plated copper braid and PTFE over all (4 leads only).	260°C 500°F

\* Temperature rating for leads and last 2" of case.

## Specification and order options

S914	Model number from table
PD	100 $\Omega$ Platinum, 0.00385 TCR
06	Tolerance at 0°C: ▼06 = $\pm 0.06\%$ , EN60751 Class A 12 = $\pm 0.12\%$ , EN60751 Class B
G	Leadwire code from table
40	Case length: Specify in 0.1" increments (Ex: 40 = 4.0 inches) ▼: 40, 60, 90, 120, 180
Z	Number of leads: ▼Z = 3 leads X = 4 leads
120	Lead length in inches ▼: 120
BS	Probe termination: ▼BS = Boot and spring B = Boot only ▼N = No boot or spring
S914PD06G40Z120BS = Sample part number	

▼ = STANDARD OPTIONS

Specifications subject to change



# Mineral-insulated RTDs

## Overview

Mineral-insulated RTDs provide excellent performance, even when exposed to high levels of shock and vibration in tough industrial environments. Typical applications include process control and steam turbine efficiency measurement.

Probes can be bent around a mandrel diameter at least 3 times the probe diameter without kinking.

Custom designed RTDs and thermocouples are available.

- Mineral MgO packing protects element from shock and contamination
- Field bendable
- Inconel or stainless steel sheath
- High precision RTD elements for stable, repeatable measurements
- Dual sensing element model S953 is excellent for redundancy and failure protection

## Specifications

**Element:** Platinum, 100  $\Omega$  at 0°C, TCR=0.00385  $\Omega/\Omega/^\circ\text{C}$ .

**Temperature range:** Reduced to 260°C (500°F) for leadwires and potting boot.

S932, S933: -200 to 650°C (-328 to 1202°F).

S942, S943, S944: -200 to 550°C (-328 to 1022°F).

S953: -200 to 260°C (-328 to 500°F).

**Tolerance:** EN60751 Class B ( $\pm 0.12 \Omega = \pm 0.3^\circ\text{C}$ ) or Class A ( $\pm 0.06 \Omega = \pm 0.15^\circ\text{C}$ )

**Repeatability:** Meets EN60751 requirements. Typical shift less than 0.05°C (0.1°F) when cycled over temperature range.

**Stability:** Meets EN60751 specifications after 250 hours exposure to extremes of temperature range. Typical drift of less than 0.05°C (0.1°F) at 0°C.

**Vibration:** Withstands 10 to 5000 Hz at 2 G's per EN60751. Also withstands 50 to 250 Hz at 50 G's at 500°C.

**Shock:** Withstands a 1 meter drop onto an 8 mm steel plate (1 meter is 4 times the EN60751 height requirement of 250 mm).

**Time constant:** 10 seconds typical in moving water.

**Pressure rating:** 69 bar (1000 psi) at 25°C.

**Insulation resistance:** 10 megohms minimum at 100 VDC.

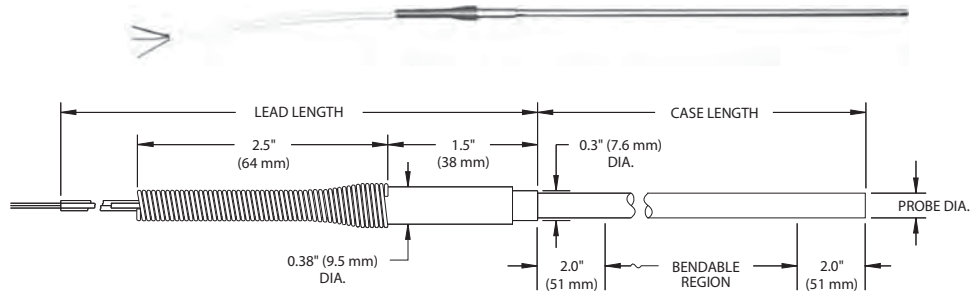

## Single element models

Probe diameter	Max. temp.	Case material	Model
0.236" (6.0 mm)	550°C (1022°F)	316 stainless steel	▼S942
0.236" (6.0 mm)	650°C (1202°F)	Inconel 600	▼S932
0.250" (6.4 mm)	550°C (1022°F)	316 stainless steel	▼S943
0.250" (6.4 mm)	650°C (1202°F)	Inconel 600	▼S933
0.188" (4.8 mm)	550°C (1022°F)	316 stainless steel	▼S944

## Dual element model

Probe diameter	Max. temp.	Case material	Model
0.250" (6.4 mm)	550°C (1022°F)	316 stainless steel	S953

## Specification and order options

S933	Model number from table
PD	100 $\Omega$ platinum, 0.00385 TCR
06	Tolerance at 0°C: ▼06 = $\pm 0.06\%$ , EN60751 Class A (NA for dual element S953) 12 = $\pm 0.12\%$ , EN60751 Class B
T	Leadwire insulation: ▼T = PTFE leadwires C = PTFE cable (4 lead only, NA for dual element S953)
30	Case length: Specify in 0.1" increments (Ex: 30 = 3.0 inches) ▼: 30, 40, 120, 180
Z	Number of leadwires: Y = 2 leads per element ▼Z = 3 leads per element X = 4 leads per element
120	Lead length in inches ▼: 120
BS	Lead exit configuration: (B or BS option recommended for best lead exit strength) ▼BS = Potting boot and strain relief spring B = Potting boot ▼N = No potting boot or spring
S933PD06T30Z120BS = Sample part number	

▼ = STANDARD OPTIONS

Specifications subject to change



# Compact Plug Sensor

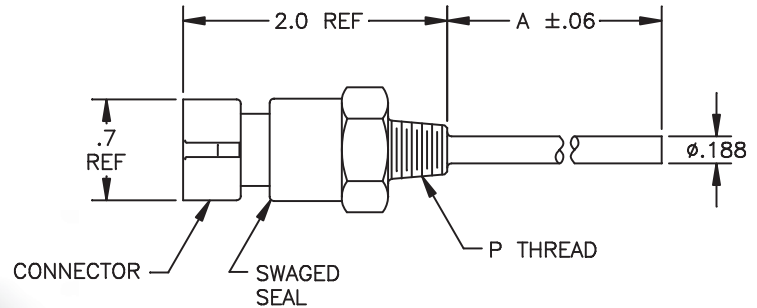

## Overview

The S205459 is a platinum RTD temperature sensor with convenient plug in connection.

- Sensor measuring and operating range is from -50 to 300°F (-45.5 to 148.9°C).
- Connection is made using an industry-standard Packard/Delphi: Metri-pack 150 connector

## Specifications

**Temp Range:** -50 to 300°F (-45.5 to 148.9°C)

**Case Material:** 316 Stainless Steel

**Connector:** Packard /Delphi METRI-PACK 150

### Pressure Rating:

Stainless Steel: 1500 psi

Brass: 500 psi

**Insulation Resistance:** 1000 megaohms min at 500 V

**Vibration:** Withstands 10 to 2000 Hz at 20 G's min per MIL-STD-202, Method 204 Test Condition D

**Shock:** Withstands 100 G's min sine wave shock of 8 milliseconds duration.

**Sensor Housing:** Stainless steel sensor end with a choice of NPT threads; end connector (Packard/Delphi: Metri-pack 150)

## Specification and order options

S205459	Model number: S205459 Compact Plug Sensor
PD	Element Type: ▼PD Platinum (0.00385 TCR) 100Ω +/- 0.12% at 0°C ▼PF Platinum (0.00385 TCR) 1000Ω +/- 0.12% at 0°C
20	Case Length: ▼10 = 1.0" ▼20 = 2.0" ▼30 = 3.0" ▼40 = 4.0"
P2	Thread size: ▼P2 = 1/8 -27 NPT ▼P4 = 1/4 -18 NPT ▼P6 = 3/8 -18 NPT ▼P8 = 1/2 -14 NPT
S	Case Material: ▼S = Stainless Steel
S205459PD20P2S = Sample Part Number	

Contact Minco to learn more about custom design options for your application.

## S205459 Mating Cable Assembly

- 72" Shielded cable
- 2-conductor, AWG #18, copper braid shield with drain wire
- Terminated with a female Metri-pack 150 connector

## Specification and order options:

### S205459 Mating Cable Assembly

AC203350	Model Number: AC203350
L72	72" lead length
AC203350L72 = Sample Part Number	

▼ = STANDARD OPTIONS

Specifications subject to change

# Integrated Sensor/Transmitter

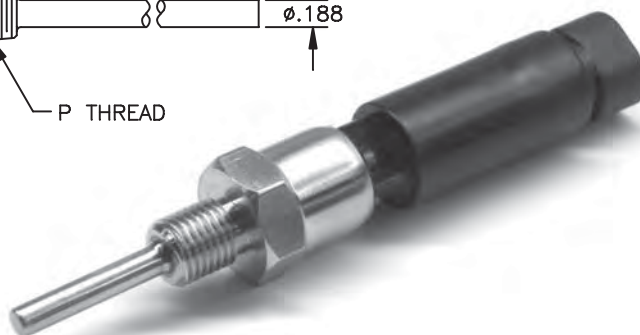
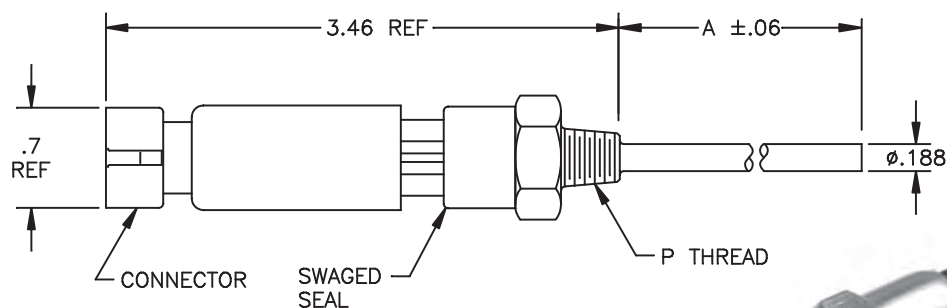

## Overview

The TT363 is an integrated platinum RTD temperature sensor with 4-20mA current loop output. Combines transmitter capability with a platinum sensing element in a single package for an easier-to-install temperature sensing solution.

- Power and signal are provided through a 4-20mA current loop connection.
- Sensor measuring and operating range is from -50 to 300°F (-45.5 to 148.9°C).
- The high-temperature plastic case and electronics can be used in applications with an ambient temperature up to 185°F (85°C).
- Connection is made using an industry-standard Packard/Delphi: Metri-pack 150 connector.

## Specifications

**Output:** 4-20mA over range specified, linear with temperature.

**Sensor Operating Temperature:** -50 to 300°F (-45.5 to 148.9°C)

### Ambient Temperature:

Operation: -40 to 185°F (-40 to 85°C), non-condensing

Storage: -67 to 212°F (-55 to 100°C), non-condensing

**Supply Voltage:** 7.6 to 35VDC, reverse polarity protected

**Loop resistance:** Maximum allowable resistance of the signal-carrying loop, including wires and load resistors given by:  $R_{loopmax} = (V_{supply} - 7.6) / .02Amps$

**Warmup drift:** Less than +/-0.025mA; stable within 30 minutes.

**Ambient temperature error:** Less than +/-0.15mA

**Voltage Stability:** Change in loop current  $< \pm 0.01$  mA from 7.6 to 35 VDC

**Sensor Housing:** Stainless steel sensor case with a choice of NPT threads; transmitter body is nylon with 30% glass plastic encapsulation; end connector (Packard/Delphi: Metri-pack 150)

## Specification and order options

TT363	Model number: TT363 Temperature Sensor/Transmitter
AN	Range Code: Temperature range code [AN = -17.8 to 148.9°C(0 to 300°F)]
20	Case Length: 10 = 1.0" 20 = 2.0" 30 = 3.0" 40 = 4.0"
P2	Thread size: P2 = 1/8 -27 NPT P4 = 1/4 -18 NPT P6 = 3/8 -18 NPT P8 = 1/2 -14 NPT
S	Case Material: S = Stainless Steel
TT363AN20P2S = Sample Part Number	

Contact Minco to learn more about custom design options for your application.

## TT363 Mating Cable Assembly

- 72" Shielded cable
- 2-conductor, AWG #18, copper braid shield with drain wire
- Terminated with a female Metri-pack 150 connector

## Specification and order options:

### TT363 Mating Cable Assembly

AC203350	Model Number: AC203350
L72	72" lead length
AC203350L72 = Sample Part Number	

Specifications subject to change

# Conductivity Level Sensor



## Overview

The LT364 Level Sensor provides point fluid detection with virtually any conductive fluid. Two 316 stainless steel pins provide for operation in mildly corrosive fluids within plastic or metal containers. Fluid presence is measured by passing a low voltage AC signal between the stainless steel probes. The use of an AC voltage eliminates the effects of galvanic corrosion on the probes. Power to the sensor and output from the sensor is derived from a current loop. Sensor output is 8 mA with fluid present and 16 mA with no fluid present.

- No calibration necessary.
- Injection molded, high-temperature plastic case.
- Electronics can be used in applications with an ambient temperature up to 185°F (85°C).
- Connection is made using an industry-standard Packard/Delphi Metri-pack 150 connector providing an easy-to-connect, polarized connection.

## Application Ideas

- Radiator low-fluid level detection
- Pump recovery tanks
- Fluid leak detection
- Parts washers
- Automated test equipment

## Specifications

### Sensor Output:

8 mA ± 1 mA with fluid present and 16 mA ± 1 mA with no fluid present

### Ambient Temperature (electronics):

Operation: -40 to 185°F, non-condensing  
Storage: -67 to 212°F, non-condensing

**Supply Voltage:** 7.6 to 35VDC, reverse polarity protected

**Loop resistance:** Maximum allowable resistance of the signal-carrying loop, including wires and load resistors given by:  $R_{loopmax} = (V_{supply} - 7.6) / .02 \text{ Amps}$

**Voltage Stability:** Change in loop current < ±.01 mA from 7.6 to 35 VDC

**Sensor Housing:** 3/8" - 18 NPT process thread, nylon with 30% glass plastic encapsulation; end connector is Packard/Delphi Metri-pack 150.

**Weight:** Approximately 2.5 oz (70 g)

## Specification and order options

L015	Model number: L015 Level Sensor
<i>Variable lengths are available. Contact Minco to learn more about custom design options for your application.</i>	

## LT364 Mating Cable Assembly

- 72" Shielded cable
- 2-conductor, AWG #18, copper braid shield with drain wire
- Terminated with a female Metri-pack 150 connector

## Specification and order options

### LT364 Mating Cable Assembly

AC203350	Model Number: AC203350
L72	72" lead length
AC203350L72 = Sample Part Number	

▼ = **STANDARD OPTIONS**  
Specifications subject to change

### Wiring Diagram

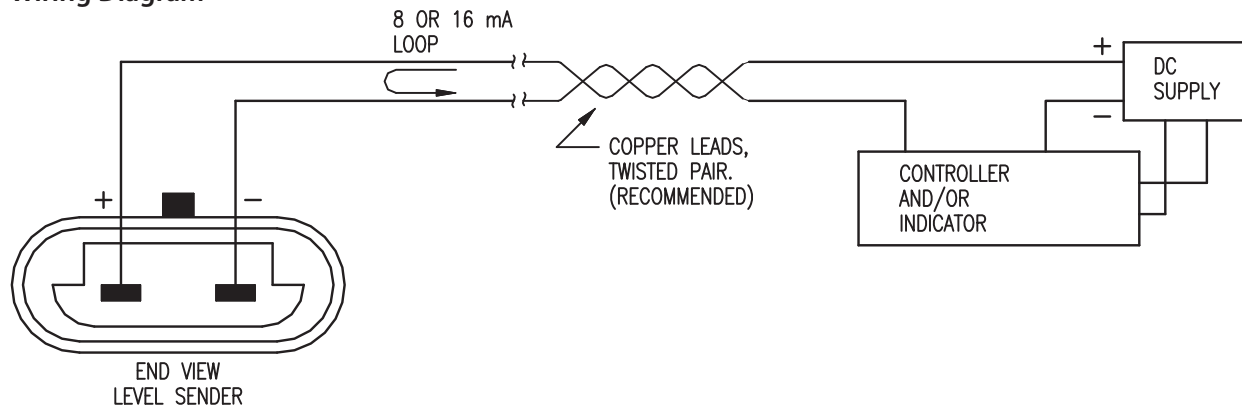

### Dimensional Drawings

#### Side View

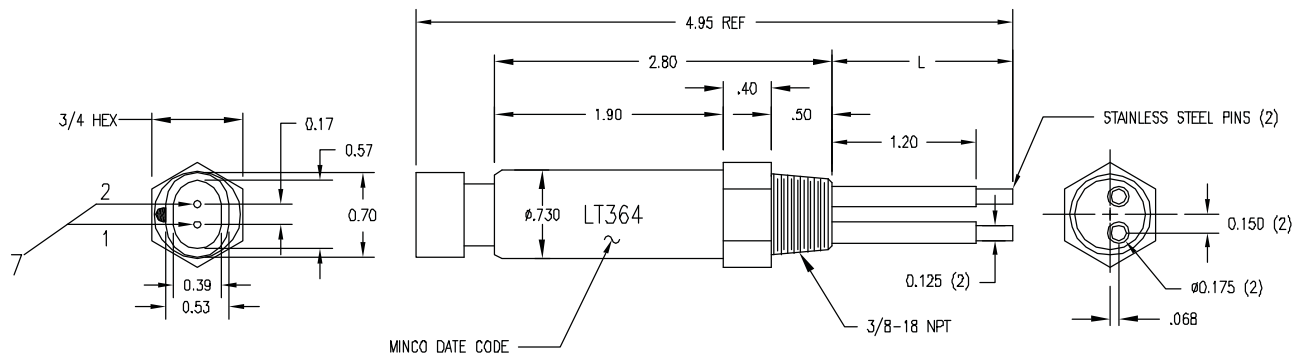

#### Connection End

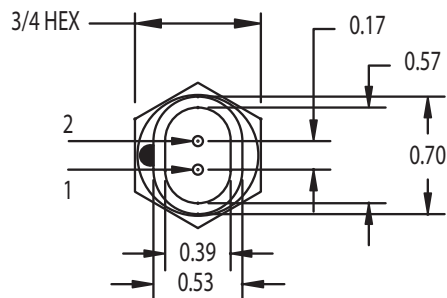

#### Measurement End

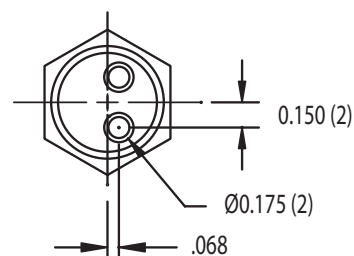

▼ = **STANDARD OPTIONS**  
 Specifications subject to change

# How to Shorten Cut-to-length Probes



Shorten probes easily with a tubing cutter

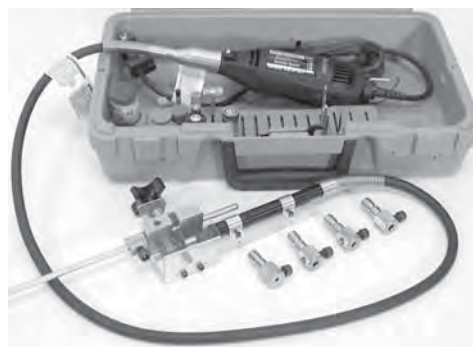

The AC101248 probe cutting system makes clean, precise cuts.

## Overview

Many probe models can be cut to the required length using an ordinary tubing cutter. Cut-to-length models are marked with the icon shown at right.



Benefits are:

- You can keep standard lengths in inventory, and shorten them as needed for urgent requirements
- Stocking and shortening probes, instead of ordering a few pieces at a time, may let you take advantage of quantity discounts
- Minco stocks most cut-to-length probes and can trim and ship them within 24 hours of your call

## How to shorten probes

Remove the PTFE or brass ferrule from the lead exit end of the probe. Mark the proper length, then cut, going slowly to avoid crimping the case or damaging the leads. Use a good quality tubing cutter that is intended to cut stainless steel tubing or conduit. The cutter must have a sharp blade to prevent "rolling in" during cutting of the tubing. Suitable models are available from Imperial Eastman and Sears Industrial.

After cutting, discard the hollow tube section, carefully deburr the cut end, and replace the ferrule. You can slit the PTFE ferrule for easier installation.

If you use many cut-to-length probes consider the AC101248 probe cutting system. It includes an electric Dremel™ tool (120 VAC @ 60 Hz), flexible shaft, and accessories to allow clean, precise cuts. The system includes a convenient carrying case and comes with easy to follow instructions.

# PFA or FEP Encapsulation Tubing

## Protect probes from chemical attack

### Overview

The tube is sealed at one end and can be easily heat-shrunk onto any probe. Supplied separately.

### Specification and order options

AC100375	Model number
L120	Length: 120 = 12.0" 240 = 24.0" Can be cut to any length
P	Encapsulation type: P = clear PFA F = clear FEP
188	Probe diameter: 125 = 0.125" (3.2 mm) 188 = 0.188" (4.8 mm) 215 = 0.215" (5.5 mm) 250 = 0.250" (6.4 mm)
AC100375L120P188 = Sample part number	

### FEP Specifications

FEP: Fluorinated Ethylene Propylene  
**Temperature range:** -70 to 200°C (-94 to 392°F).  
 Maximum temperature 204°C (400°F)

Excellent dielectric insulation properties, chemically resistant, unaffected by weather, extreme heat, or cold temperatures.

### PFA Specifications

PFA: Perfluoroalkoxy  
**Temperature range:** -70 to 260°C (-94 to 500°F).  
 Maximum temperature 260°C (500°F)

Combines attributes of PTFE and FEP, chemically resistant to all common solvents, maintains mechanical strength at high temperatures.

*Specifications subject to change*



## ▶ SECTION 3: ACCESSORIES

- A wide selection of fittings and accessories adapt sensors to any installation
- Adjustable fittings with cut-to-length probes provide off-the-shelf versatility
- Choose from a variety of materials to meet your critical environment requirements

Connection heads.....	3-2 to 3-3
Spring-loaded holders.....	3-4
Fluid immersion fittings.....	3-5
Economy thermowells.....	3-6
HVAC thermowells.....	3-6
Reduced tip thermowells.....	3-7
Tapered thermowells.....	3-7
Flanged thermowells.....	3-8
Bayonet fittings.....	3-9
Extensions.....	3-9
Metric accessories.....	3-10
Feedthroughs.....	3-11
Leadwire and cable seal.....	3-12 to 3-13
Elastomer rubber-filled cable.....	3-14
Extension wire.....	3-15

# Connection Heads

Dimensions in inches (mm)		Body/gasket material	IP/NEMA Rating	Max Temp.	Pipe thread codes	Temptran™ models	Approx. weight	Model
<b>CH103</b> 3.5 (89) H 3.5 (89) L 1.9 (48) D 1.9 (48) T		Nickel-plated cast iron with SS chain/silicone gasket	IP55 Type 3 and 4	316°C (600°F)	P1, P2, P3, P4	All models except TT220 and TT221	2.0 lbs. (0.9 kg.)	▼CH103
<b>CH366</b> 3.0 (76) H 3.7 (94) L 1.37 (35) D 1.9 (48) T		White polypropylene (FDA approved)/neoprene gasket	IP55 Type 3 and 4	110°C (230°F)	P3 only	All models except TT220 and TT221	0.2 lbs. (0.1 kg.)	▼CH366
<b>CH359</b> 3.5 (89) H 3.5 (89) L 2.0 (51) D 1.75 (44) T		Aluminum/silicone gasket	IP55 Type 3 and 4	316°C (600°F)	P1, P2, P3, P4	All models except TT220 and TT221	0.8 lbs. (0.4 kg.)	▼CH359
<b>CH301</b> 2.33 (59.2) H 4.25 (108) L 1.25 (31.8) D 3.60 (91.4) T		Aluminum/neoprene gasket	IP55 Type 3 and 4	115°C (240°F)	CH301: P3 only	Miniature TT111 and TT211 models	0.5 lbs. (0.2 kg.)	▼CH301
CH302: P2 only					▼CH302			
<b>CH360</b> 3.5 (89) H 3.5 (89) L 2.0 (51) D 1.75 (44) T		316 SS with silicone gasket	IP56 Type 3, 4 and 4x	316°C (600°F)	P1, P2, P3, P4	All models except TT220 and TT221	1.8 lbs. (0.8 kg.)	▼CH360
<b>CH335/CH339</b> 2.5 (64) Ø 3.5 (89) H 0.95 (20) D		300 series SS with Buna N O-ring	IP56 Type 3, 4 and 4x	121°C (250°F)	P3 only	All models except TT220 and TT221	2.6 lbs. (1.2 kg.)	▼CH335
		300 series SS with Buna N O-ring and chain	IP56 Type 3, 4 and 4x	121°C (250°F)	P3 only	All models except TT220 and TT221	2.6 lbs. (1.2 kg.)	CH339

Dimensions in inches (mm)		Body/gasket material	Hazardous location rating	IP/NEMA Rating	Max Temp.	Approx. weight	Model
<b>Explosionproof/flameproof heads FM/CSA approved</b>							
<b>CH104:</b> 4.60 (116.8) L 3.50 (88.9) H 1.63 (41.4) D 3.35 (85.1) T		Copper-free aluminum/Buna-N O-ring	Division 1; Division 2 Class I, Groups B, C, D; Class II, Groups E, F, G; Class I, Zone 1, AEx d IIC; Zone 1, EX d IIC; T6 (Ta = 40°C), T2 (Ta = 260°C)	IP65 Type 3 and 4	121°C* (250°F)	1.5 lbs. (0.7 kg.)	▼CH104
<b>CH106:</b> 4.20 (106.7) L 3.50 (88.9) H 1.35 (34.3) D 3.22 (81.8) T		Stainless steel/Buna-N O-ring		IP66 Type 3, 4, and 4X	121°C* (250°F)	2.4 lbs. (1.1 kg.)	▼CH106

\*Maximum temperature increases to 500°F (260°C) if O-ring is removed. Environmental rating drops to Type 3, IP54.

▼ = STANDARD OPTIONS  
Specifications subject to change

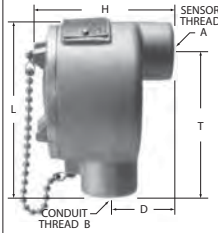
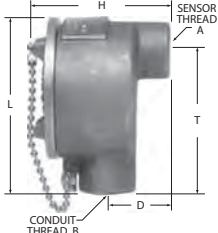

Dimensions in inches (mm)	Body/gasket material	Hazardous location rating	IP/NEMA Rating	Max Temp.	Approx. weight	Model		
<b>Explosionproof heads FM/CSA approved</b>								
<b>CH405/CH407/ CH342/CH343/ CH330/CH328:</b> 4.60 (116.8) L 3.60 (91.4) H 1.63 (41.4) D 3.70 (96.0) T		Copper-free aluminum	Division 1; Class I, Groups A, B, C, D;	IP54 Type 3	260°C (500°F)	CH405		
		Copper-free aluminum/ Buna-N O-ring	Class II, Groups E, F, G; Class III (FM approved only)	IP65 Type 3 and 4	121°C (250°F)	CH407		
		Copper-free aluminum, gray epoxy coat, no chain/ Buna-N O-ring	Division 1; Class I, Groups B, C, D;	IP66 Type 3, 4 and 4X		CH342		
		Copper-free aluminum, gray epoxy coat, with chain/ Buna-N O-ring	Class II, Groups E, F, G;			CH343		
		<b>Note: The following models have lower cost but no FM/CSA approval or label.</b>						
		Aluminum/ Buna-N O-ring	Division 1; Class I, Groups B, C, D;	IP65 Type 3 and 4	121°C (250°F)	1.4 lbs. (0.6 kg.)	CH330	
Aluminum with FDA approved white epoxy coat, no chain/Buna-N O-ring	Class II, Groups E, F, G; Class III	IP66 Type 3, 4 and 4X			CH328			
<b>Flameproof heads CENELEC/ATEX approved <math>\text{Ex}</math> II 2G Ex d IIC T6</b>								
<b>CH357/CH358:</b> 4.49 (114) L 3.60 (91.4) H 1.63 (41.4) D 3.78 (96.0) T  <b>CH356:</b> 4.20 (106.7) L 3.50 (88.9) H 1.35 (34.3) D 3.22 (81.8) T		Copper-free aluminum/ Buna-N O-ring	Zone 1, Group IIC	IP65 Type 3 and 4	55°C (104°F)	▼ CH357		
		Copper-free aluminum, epoxy coated/Buna-N O-ring	Zone 1, Group IIC	IP66 Type 3, 4 and 4X		CH358		
		Stainless steel/Buna-N O-ring				121°C (250°F)	2.4 lbs. (1.1 kg.)	▼ CH356

**Notes:**

- View photos of terminal boards under accessories at [www.minco.com](http://www.minco.com)
- All Temptran™ transmitter models may be used with connection heads on these pages.
  - AC103133 dual miniature Temptran™ mounting kit fits CH104, CH106, and CH356. CH106 and CH356 also require AC103625 modification.
  - AC103528 dual miniature Temptran™ mounting kit fits CH342, CH343, CH405, CH407, CH328, CH330, CH357, and CH358.
  - See Section 4 for more information.

**Replacement terminal boards**

Model	6-position board	8-position board
CH103	AC103029	AC101926
CH104	AC1039	AC101122
CH106	AC1039	AC101122
CH301	AC101377T6	
CH302	AC101377T6	
CH328	AC1039	AC101122
CH330	AC1039	AC101122
CH331	AC100427	
CH335	AC100427	AC101926
CH339	AC100427	AC101926
CH342	AC1039	AC101122
CH343	AC1039	AC101122
CH356	AC1039	AC101122
CH357	AC1039	AC101122
CH358	AC1039	AC101122
CH359	AC100427	AC101926
CH360	AC100427	AC101926
CH405	AC1039	AC101122
CH407	AC1039	AC101122

Specifications subject to change

**Specification and order options**

CH104	Model number from table	
P2	<b>Pipe thread code:</b> ▼P1 = $\frac{3}{4}$ - 14      Thread A $\frac{1}{2}$ - 14      Thread B ▼P2 = $\frac{3}{4}$ - 14 $\frac{3}{4}$ - 14 ▼P3 = $\frac{1}{2}$ - 14 $\frac{1}{2}$ - 14 ▼P4 = $\frac{1}{2}$ - 14 $\frac{3}{4}$ - 14 P5 (CH356 only) = $\frac{1}{2}$ - 14      M20 x 1.5 P6 (CH356 only) = $\frac{3}{4}$ - 14      M20 x 1.5	
	<b>T</b> <b>Connection type:</b> ▼T = Terminal board for wires AWG 14 or smaller ▼W = Wire nuts for wires AWG 14 to 22	
	<b>6</b> <b>Number of terminal posts or wire nuts:</b> ▼: 0, 6 8 (see terminal board table at right for model options) T0: transmitter mounting hardware W0: empty enclosure	
	CH104P2T6 = Sample part number	



# Spring-loaded Holders

## Exclusive Minco user-friendly design!

Minco's spring-loaded holders provide a quick and simple installation and removal of probe sensors — pull out and twist the knob, insert the probe until it bottoms out, and release the knob.

To remove probe, pull out and twist the knob.

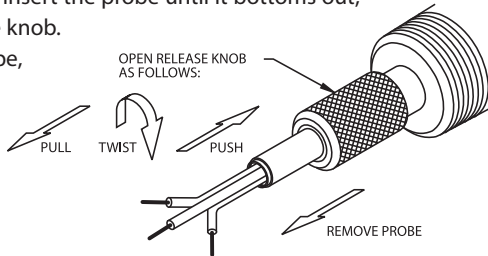

Spring pressure holds the probe tip in contact with the measuring surface for faster response and more reliable measurements. Many models feature a rubber O-ring that doesn't crimp the probe but prevents oil leakage to 50 psi (3.4 bar) at up to 260°C. High temperature models are usable to 450°C. Nylon versions provide electrical insulation.



**ALL PARTS STOCKED**

*Note: Available up to 10 pieces or contact Minco Customer Service*

Fluoroelastomer O-ring seal: 50 psi pressure rated fluid seal								
	Body material	Temperature range	Thread "CH"	Process thread	Hex size	Adder "A" (Total length)	Probe Ø inch (mm)	Model
	300 series stainless steel	-40 to 260°C (-40 to 500°F)	3/4 - 14 NPT	1/2 - 14 NPT	1 1/8" (29 mm)	3.6" (91 mm)	0.188 (4.8)	▼ FG114-1
							0.215 (5.5)	▼ FG110-1
							0.250 (6.4)	▼ FG113-1
	316 stainless steel	-40 to 260°C (-40 to 500°F)	3/4 - 14 NPT	1/2 - 14 NPT	1 1/8" (29 mm)	3.6" (91 mm)	0.188 (4.8)	FG914
							0.215 (5.5)	FG912
							0.250 (6.4)	FG911
	Nylon	-40 to 120°C (-40 to 248°F)	3/4 - 14 NPT	1/2 - 14 NPT	1" (25 mm) wrench flats	3.6" (91 mm)	0.188 (4.8)	FG314
							0.215 (5.5)	FG310
							0.250 (6.4)	FG313
	300 series stainless steel	-40 to 260°C (-40 to 500°F)	1/2 - 14 NPT	1/2 - 14 NPT	7/8" (22 mm)	2.6" (66 mm)	0.125 (3.2)	FG216N
							0.188 (4.8)	FG214N
							0.215 (5.5)	FG210N
							0.250 (6.4)	FG213N
							0.236 (6.0)	FG215N
	300 series stainless steel	-40 to 260°C (-40 to 500°F)	None	1/8 - 27 NPT	5/8" (16 mm)	2.8" (71 mm)	0.125 (3.2)	FG116
						3.6" (91 mm)	0.188 (4.8)	FG112
							0.215 (5.5)	FG111
							0.250 (6.4)	FG117
	300 series stainless steel	-40 to 260°C (-40 to 500°F)	None	1/4 - 18 NPT	5/8" (16 mm)	1.9" (48 mm)	0.188 (4.8)	FG101072
							0.215 (5.5)	FG101078
							0.250 (6.4)	FG101080

High temperature: No pressure rating or fluid seal								
	Body material	Temperature range	Thread "CH"	Process thread	Hex size	Adder "A" (Total length)	Probe Ø inch (mm)	Model
 (Set screw installation)	300 series stainless steel	-40 to 450°C (-40 to 842°F)	1/2 - 14 NPT	1/2 - 14 NPT	7/8" (22 mm)	2.3" (58 mm)	0.188 (4.8)	▼ FG801
							0.215 (5.5)	▼ FG802
							0.250 (6.4)	▼ FG810

▼ = STANDARD OPTIONS  
Specifications subject to change

# Fluid Immersion Fittings

## Overview

Install probes directly into fluid streams and pressure vessels. Simply position the fitting on the probe and tighten the sealing nut.

Fluid seal fittings are best for moderate temperatures and pressures. Pressure fittings, constructed of stainless steel, can withstand corrosive media and greater extremes of pressure and temperature.

Be sure to check the pressure ratings of probes intended for direct immersion.



**ALL PARTS STOCKED**

*Note: Available up to 10 pieces or contact Minco Customer Service*

ACCESSORIES

Fluid seal fittings to 260°C (500°F)						
	Body material	Thread "CH"	Process thread	Adder "A" (Total length)	Probe Ø inch (mm)	Model
	Brass	None	1/8 - 27 NPT	1.2" min. (31 mm)	0.188 (4.8)	▼FG143
		None	1/4 - 18 NPT			▼FG140
		None	1/8 - 27 NPT		0.215 (5.5)	▼FG126
		None	1/4 - 18 NPT			▼FG120
		None	1/8 - 27 NPT		0.250 (6.4)	▼FG151
		None	1/4 - 18 NPT			▼FG130
	Stainless steel	1/2 - 14 NPT	1/2 - 14 NPT	2.4" (61 mm)	0.188 (4.8)	▼FG142
					0.215 (5.5)	▼FG122
					0.250 (6.4)	▼FG132

*Note: Fluid seal fittings are rated to 200 psi (17 bar) when using the repositionable silicone rubber O-ring. They are rated to 500 psi (34 bar) when using the non-repositionable compression ring. These fittings come with both the O-ring and the compression ring.*

Pressure fittings to 871°C (1600°F)						
	Body material	Thread "CH"	Process thread	Adder "A" (Total length)	Probe Ø inch (mm)	Model
	316 stainless steel	None	1/8 - 27 NPT	1.5" min. (39 mm)	0.188 (4.8)	FG141T3P2
		None	1/4 - 18 NPT			FG141T3P4
		None	1/2 - 14 NPT			FG141T3P8
		None	1/8 - 27 NPT		0.250 (6.4)	FG141T4P2
		None	1/4 - 18 NPT			FG141T4P4
		None	1/2 - 14 NPT			FG141T4P8
	316 stainless steel	1/2 - 14 NPT	1/2 - 14 NPT	2.9" (74 mm)	0.125 (3.2)	FG145T2
					0.188 (4.8)	FG145T3
					0.250 (6.4)	FG145T4

*Note: Pressure fittings are rated to 1500 psi (103 bar) at 25°C/77°F, reducing to 500 psi (34 bar) at 630°C/1166°F. The probe cannot be repositioned after installation.*

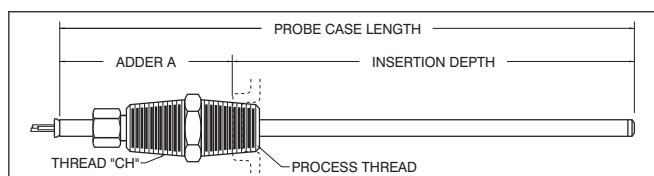

To determine the ideal probe length add the insertion depth to the adder A for the fitting you will use.

▼ = **STANDARD OPTIONS**  
Specifications subject to change

# Economy and HVAC Thermowells



## Overview

Thermowells protect probes from pressure, flow, and corrosion. The models on this page have integral fittings for probe and connection head mounting.

Immerse the thermowell at least 2.5" (65 mm) for accurate readings. The well should extend beyond the center of the fluid stream without touching the opposite wall. Installation in an elbow or tee may be necessary for sufficient immersion in small pipes.

For fastest time response, Minco can furnish thermowells with heat sink compound in the tip. This eliminates the air gap between the probe and inside wall of the well and can reduce time constant by as much as 50%. Order AC101750.

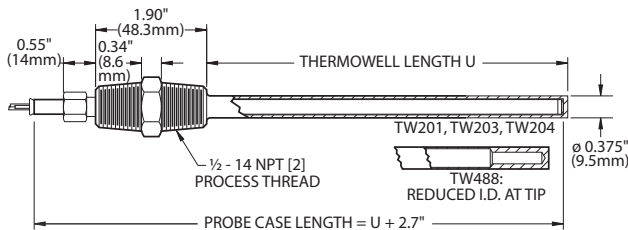

## Economy thermowell specifications

**Models:** TW204 / TW201 / TW203

**Probes:** use with tip-sensitive probes on pages 2-2 to 2-3

**Body material:** 300 series stainless steel, nickel-plated brass sealing nut with brass compression ring

**Temperature limit:** 260°C (500°F)

**Pressure rating:** 1000 psi (69.9) bar

**Hex size:** 7/8" (22 mm)

**Standard U dimension:** 0.1" increments to 48"

Probe diameter	Thread "CH"	Process Thread	Model
0.188" (4.8 mm)	1/2-14 NPT	1/2-14 NPT	TW204
0.215" (5.5 mm)			TW201
0.250" (6.4 mm)			TW203

## HVAC thermowell specifications

**Model:** TW488

**Probes:** use with HVAC probes on page 8-19

**Body material:** 316 stainless steel, nickel-plated brass sealing nut with silicone rubber O-ring

**Temperature limit:** 260°C (500°F)

**Pressure rating:** 1880 psi (129.7) bar

**Hex size:** 7/8" (22 mm)

**Standard U dimension:**

3.0, 6.0, 12.0, and 18.0". Other lengths are available.

Probe diameter	Thread "CH"	Process Thread	Model
0.250" (6.4 mm)	1/2-14 NPT	1/2-14 NPT	TW488
Tip 0.188" (4.8 mm)			

## Specification and order options

TW203	Model number
U	
60	Thermowell length U: Specify in 0.1" increments (Ex: 60 = 6.0 inches)
TW203U60 = Sample part number	



**STOCKED PARTS AVAILABLE**

▼ = **STANDARD OPTIONS**  
Specifications subject to change

# Reduced Tip and Tapered Thermowells



Reduced Tip Thermowell



Tapered Thermowell

## Overview

Protect probes from pressure, flow, and corrosive fluids. Thermowells on this page are machined from solid bar stock. Specify reduced tip style for fast response, tapered style for maximum rigidity in high flow conditions.

Immerse the thermowell at least 2.5" (65 mm) for accurate readings. The well should extend beyond the center of the fluid stream without touching the opposite wall. Installation in an elbow or tee may be necessary for sufficient immersion in small pipes.

Spring-loaded probe installation is recommended, using either spring-loaded holders or bayonet-mount probes. 0.250" diameter probes provide the best fit.

For fastest time response, Minco can furnish thermowells with heat sink compound in the tip. This eliminates the air gap between the probe and inside wall of the well and can reduce time constant by as much as 50%. Order AC101750.

Contact Minco Sales and Customer Service for other thermowell styles and materials.

## Reduced tip thermowell specifications

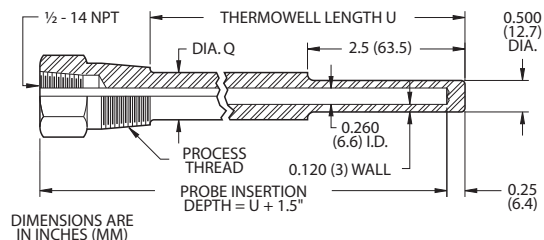

### Temperature limit:

Stainless steel: 900°C (1650°F).

Monel: 538°C (1000°F).

**Standard U dimensions:** 2.5, 4.5, 6.0, 7.5, 8.0, 10.5, 13.5, 16.5, and 22.5". Other dimensions available.

Body material	Process thread (NPT)		
	1/2 - 14	3/4 - 14	1 - 11 1/2
304 stainless steel	TW239	TW228	TW238
316 stainless steel	▼TW222	▼TW248	TW234
Monel	TW1204	TW447	TW1231
Diameter Q	0.625" (16 mm)	0.750" (19 mm)	0.875" (22 mm)
Hex size	1.125" (29 mm)		1.375" (35 mm)

## Tapered thermowell specifications

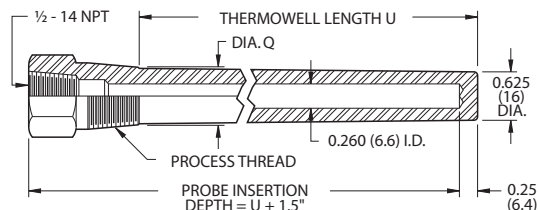

### Temperature limit:

Stainless steel: 900°C (1650°F).

**Standard U dimensions:** 2.5, 4.5, 6.0, 7.5, 8.0, 10.5, 13.5, 16.5, and 22.5". Other dimensions available.

Body material	Process thread (NPT)	
	3/4 - 14	1 - 11 1/2
304 stainless steel	TW477	TW252
316 stainless steel	▼TW1218	▼TW1237
Diameter Q	0.875" (22 mm)	1.06" (27 mm)
Hex size	1.125" (29 mm)	1.375" (35 mm)

## Pressure ratings

Body material	Temperature		
	21°C (70°F)	538°C (1000°F)	650°C (1200°F)
304 stainless steel	7000 psi 483 bar	4500 psi 310 bar	1650 psi 114 bar
316 stainless steel	7000 psi 483 bar	5100 psi 352 bar	2500 psi 172 bar
Monel	6500 psi 448 bar	1500 psi 103 bar	

## Specification and order options

TW222	Model number from table
U	
45	Thermowell length U: Specify in 0.1" increments (Ex: 45 = 4.5 inches) ▼: 25, 45, 60
TW222U45 = Sample part number	



**STOCKED PARTS AVAILABLE**

▼ = STANDARD OPTIONS  
Specifications subject to change

# Flanged Thermowells

## Overview

Flanged thermowells are available in three standard flange sizes: 1.0", 1.5", and 2.0" per ANSI B16.5. Specify U dimension and pressure rating.

Immerse the thermowell at least 2.5" (65 mm) for accurate readings. The well should extend beyond the center of the fluid stream without touching the opposite wall. Installation in an elbow or tee may be necessary for sufficient immersion in small pipes.



TW1219 Flanged Straight Thermowell

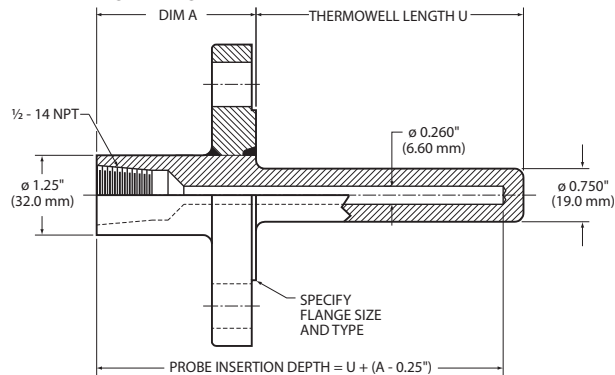

TW1220 Flanged Tapered Thermowell

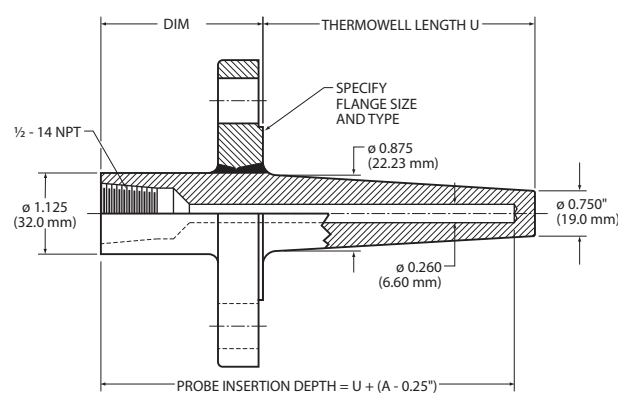

## Specifications - Models TW1219 / TW1220

**Body material:** 316 stainless steel.

**Temperature limit:** 607°C (1125°F).

**Pressure rating:** Specify flange pressure rating.  
(1 bar = 14.5 psi).

Pressure rating	Dimension A
150, 300, 400, 600 psi	2.25" (64mm)
900, 1500, 2500 psi	3.25" (83mm)

**Thread:** 1/2-14 NPT internal thread.

**Probe diameter:** 0.250" (6.4 mm).

**Standard U dimensions:** 2.5, 4.5, 6.0, 7.5, 8.0, 10.5, 13.5, 16.5, and 22.5". Other dimensions available.

## Specification and order options:

TW1219	Model number: TW1219 = Straight TW1220 = Tapered
U	
105	Thermowell length U: Specify in 0.1" increments (Ex: 105 = 10.5 inches)
S	
10	Flange size: 10 = 1.0" 15 = 1.5" 20 = 2.0"
F	
300	Pressure rating in pounds per square inch
RF	Flange type: RF = Raised face RTJ = Ring type joint
TW1219U105S10F300RF = Sample part number	

▼ = STANDARD OPTIONS

Specifications subject to change

# Bayonet Fittings, Extensions





**ALL PARTS STOCKED**

## Bayonet adapter style

Bayonet fittings are for spring-loaded installation of probes equipped with springs and lockcaps. Insert the probe, hook the lockcap over the pin on the fitting, and release.

*Note: Available up to 10 pieces or contact Minco Customer Service*

Bayonet adapter style	Body material	Thread "CH"	Process thread	Hex size	Adder "A"	Probe diameter	Model
	303 stainless steel	None	1/8" - 27 NPT	None	1.2" min. (31 mm)	0.188" (4.8 mm)	▼FG180
	316 stainless steel	1/2" - 14 NPT	1/2" - 14 NPT	7/8" (22 mm)	2.4" (61 mm)	0.188" (4.8 mm)	▼FG144T3

*Note: Temperature limit: 871°C (1600°F)*

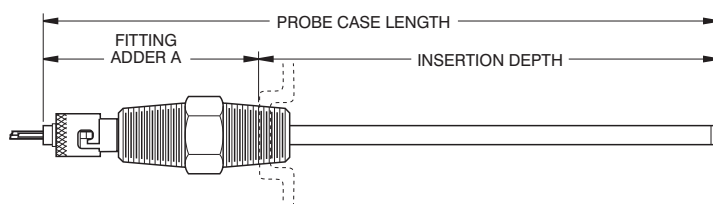

## Extension nipples, couplings, unions

Extensions in assemblies serve to isolate connection heads from process connections in order to clear pipe insulation or limit heat conduction into the head. Choose from galvanized or stainless steel nipples, couplings, and unions.

Nipples are short lengths of pipe to extend connection heads away from processes. Couplings and unions have two 1/2" - 14 NPT female threads to join nipples to other fittings. Unions allow installation without rotating the connection head.

Style	Length	Galvanized steel to 260°C (500°F)	Stainless steel to 871°C (1600°F)
 <p>Nipple</p>	1.2" (34 mm)	FG563 Adder C: 0.2" (5mm)	FG537 Adder C: 0.2" (5mm)
	2.0" (51 mm)	▼FG556L20 Adder C: 1.0" (25mm)	▼FG579L20 Adder C: 1.0" (25mm)
	3.0" (76 mm)	▼FG556L30 Adder C: 2.0" (51mm)	▼FG579L30 Adder C: 2.0" (51mm)
	4.0" (102 mm)	▼FG556L40 Adder C: 3.0" (76mm)	▼FG579L40 Adder C: 3.0" (76mm)
	6.0" (152 mm)	▼FG556L60 Adder C: 5.0" (127mm)	▼FG579L60 Adder C: 5.0" (127mm)
 <p>Coupling</p>	Same as Adder B length	▼FG602 Adder B: 1.7" (43mm)	▼FG854 Adder B: 1.4" (36mm)
 <p>Union</p>	Same as Adder B length	▼FG709 (no fluid seal) Adder B: 1.9" (48 mm)	▼FG714 Adder B: 1.6" (41 mm)

*Note: All threads are 1/2" - 14 NPT [2].*

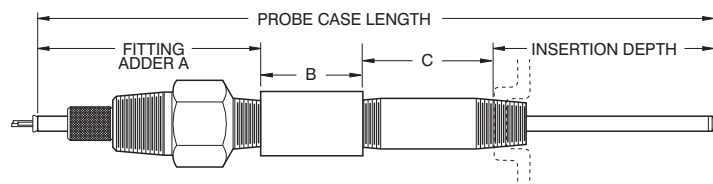

▼ = STANDARD OPTIONS  
Specifications subject to change

ACCESSORIES

# Metric Accessories

## Overview

Metric fittings and thermowells help you design your equipment to meet global standards. Use these fittings to install Minco sensors in process lines, rotating machinery, and all types of industrial equipment.

Special threads and accessories are available. See Eurostyle Sensors Assemblies on page 1-22.





**Fluid seal spring-loaded holders:** Spring-loaded holders provide fast installation and simple adjustment or removal of probes. Minco's unique designs work with straight probes and provide sealing for the typical oil pressures found in rotating machines.

**Fluid seal fittings:** Fluid seal fittings are a low cost solution where a connection head is not required.

**Bayonet adapters:** Bayonet adapters work with Minco's spring-loaded bayonet fitted probes.

**Adapter bushings:** Adapter bushings allow fitting 1/2 - 14 NPT fittings into metric threaded process connections.

**Thermowells:** Thermowells provide high-pressure protection and allow probe replacement without opening the system.

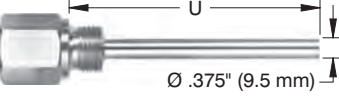
	Body material	Temp. limit	Pressure rating	Thread "CH"	Process thread	Hex size	Probe diameter	Model
 <p><b>Fluid seal spring-loaded holder</b> Probe length adder A: 3.6" (91mm)</p>	303 series stainless steel per DIN 1.4300, AISI 303	260°C (500°F)	3.4 bar (50 psi)	3/4 - 14 NPT	G 1/2 ISO 229/1 parallel	1 1/16" (27 mm)	0.188" (4.8 mm)	MFG812P477
							0.215" (5.5 mm)	MFG812P546
							0.250" (6.4 mm)	MFG812P635
 <p><b>Fluid seal fitting</b> Probe length adder A: 1.1" min. (28 mm)</p>	Brass	260°C (500°F)	Silicone rubber O-ring: 17.2 bar (250 psi) Brass compression ring: 34.5 bar (500 psi)	None	R 1/4 ISO 7/1 tapered	9/16" (14 mm)	0.250" (6.4 mm)	MFG816
 <p><b>Bayonet adapter</b> Probe length adder A: 1.2" (31 mm)</p>	303 series stainless steel per DIN 1.4300, AISI 303	871°C (1600°F)	No fluid seal	None	R 1/8 ISO 7/1 tapered	None	0.188" (4.8 mm)	MFG817
 <p><b>Adapter bushing</b> Probe length adder A: 1.2" (31 mm)</p>	303 series stainless steel per DIN 1.4300, AISI 303	871°C (1600°F)	No fluid seal	1/2 - 14 NPT (Female)	G 1/2 ISO 229/1 parallel	1 1/16" (27 mm)	All	▼ MFG811
 <p><b>Thermowell</b> Probe length = U + 30 mm + fitting adder A (U= 13 mm min./1200 mm max.)</p>	303 series stainless steel per DIN 1.4300, AISI 303	871°C (1600°F)	190 bar (2755 psi) at 25°C, reducing to 34 bar (493 psi) at 600°C	1/2 - 14 NPT (Female)	G 1/2 ISO 229/1 parallel	1 1/16" (27 mm)	0.250" (6.4 mm)	MTW1208

## Thermowell specification and order options

MTW1208	Model number
U	
100	Thermowell length U: Specify in millimeters Minimum: 13 mm Maximum: 1200 mm
MTW1208U100 = Sample part number	

▼ = STANDARD OPTIONS

Specifications subject to change



# Feedthroughs - Prevent Oil Seepage

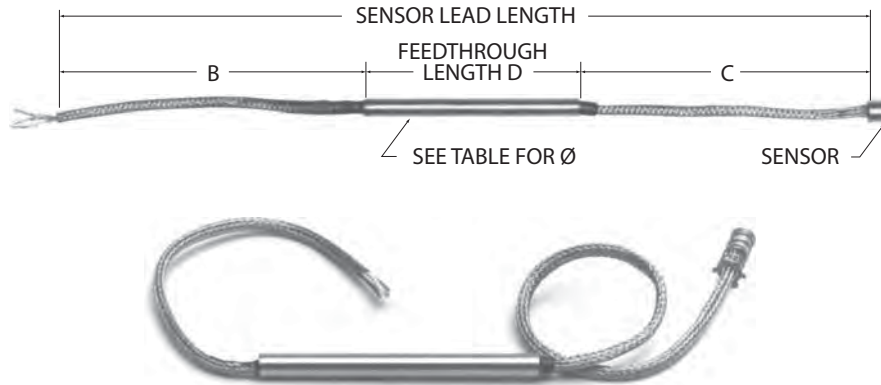

ACCESSORIES

## Overview

Feedthroughs provide an oil-tight-seal where a cable exits a machine housing. The stainless steel tube is epoxy filled and each wire is sealed to the individual conductor. This prevents wicking of oil inside the wires as well as leakage around the wire insulation. The pressure rating to 25 psi (1.7 bar) is suitable for most oil and coolant pump systems.

Feedthroughs can be ordered as an accessory to any sensor in this guide. When ordering feedthroughs with case style B bearing sensors, the spring and retaining ring are automatically included. Fluid seal fittings allow easy installation of feedthroughs into standard NPT threaded machine housings. See page 3-4, 3-5 or 3-10 (metric) for fluid seal fittings, or page 3-12 for transitions through housings.

## Specifications

**Material:** Stainless steel with epoxy potting.

**Temperature limit:** 149°C (300°F).

**Pressure limit:** 25 psi (1.7 bar).

Sheath Ø	Max. Cable Ø	Model
0.188" (4.8 mm)	0.12" (3.0 mm)	AC958
0.215" (5.5 mm)	0.14" (3.6 mm)	AC717
0.250" (6.4 mm)	0.17" (4.3 mm)	AC718
0.375" (9.5 mm)	0.26" (6.6 mm)	AC961

## Specification and order options

AC717	Model number from table
B6	Lead length B or C in inches (specify one): B = Lead end C = Sensor end
D250	Feedthrough length D in 0.01" increments: Min. length: 1.6" (40.6 mm) (Ex: 250 = 2.50")
AC717B6D250 = Sample part number	

▼ = **STANDARD OPTIONS**  
Specifications subject to change



# FG Series Cable Seals

Prevent oil wicking with bearing embedment sensors



**STOP OIL SEEPAGE!**

## Overview

Minco's FG series cable seals prevent oil wicking with bearing embedment sensors in rotating equipment. They were specifically designed for use with Minco's innovative elastomer filled cables to prevent oil wicking along the sensor cable. FG series seals can also be used to seal around individual leadwires and rigid tubing. The seals include a grommet that provides a tight seal and also allows adjustment of the cable or leadwire position.

## Configurations

FG series cable seals are available in three configurations, all of which perform the same basic function of providing an adjustable, oil-tight seal on Minco elastomer filled cables, leadwires, rigid probes or feed-through tubing.

FG1015	FG3015	FG4015
<p>Connection thread    Process thread</p>	<p>Connection thread    Process thread</p>	<p>Connection thread    Process thread</p>
<ul style="list-style-type: none"> <li>• Feed-through grommet</li> </ul>	<ul style="list-style-type: none"> <li>• Split grommet</li> </ul>	<ul style="list-style-type: none"> <li>• Feed-through or split grommet</li> <li>• ATEX and IECEx certified</li> </ul>

## Installation

The split grommet fits over the cable where access to the cable ends isn't practical. The feed-through grommet requires the cables to be threaded through the grommet. Tightening the fitting compresses the grommet, forming the seal. To adjust the position of the cables in the seal, simply loosen the fitting to decompress the grommet and pull the wire or cable through the grommet to the desired position and retighten the fitting.

Note:

- Plugs are provided to fill unused holes on 6-hole and split grommets.
- Insulated leadwires must be used; do not use bare stranded leadwires.
- Wires must be oil sealed on sensor end.

## Specifications

Fitting material	Stainless steel (303 or 316)
Grommet material	Fluoroelastomer or Neoprene
Temperature range (grommet)	Fluoroelastomer: -40 to 90°C (-40 to 194°F) Neoprene: -40 to 75°C (-40 to 167°F)
Pressure	50 psi (3.4 bar) at 20°C
Ingress protection rating*	IP65/IP66
ATEX and IECEx certification*	ATEX  II 2 G Ex d e IIc Gb IECEx Ex d e IIc Gb

\*FG4014 and FG4015 only

▼ = **STANDARD OPTIONS**  
Specifications subject to change

## Ordering Information

FG products can be ordered as complete assemblies or as piece parts (fitting body and grommet kit separately).

### Cable Seal Assemblies

To configure your assembly, select from the options listed below to determine the complete assembly part number. Use the code shown in **bold** for each selection. Assemblies include fitting body, grommet and compression plugs, and washer (1015).

<b>FG1015</b>	Model number: ▼ <b>FG1015</b> : Cable seal assembly (feed-through grommet) ▼ <b>FG3015</b> : Cable seal assembly (split grommet) ▼ <b>FG4015</b> : Cable seal assembly (feed-through grommet, certified) ▼ <b>FG4015</b> : Cable seal assembly (feed-through grommet, certified - add S to end of part number for certified version)					
<b>P1</b>	Pipe thread code:					
	Code	Connection thread	Process thread	Overall length	Connection hex size	
	▼ <b>P1</b>	1/2" 14 NPT	3/4" 14 NPT	3.25"	1-1/8"	
	▼ <b>P2</b>	3/4" 14 NPT				
	▼ <b>P3</b>	1/2" 14 NPT	1/2" 14 NPT			
	▼ <b>P4</b>	3/4" 14 NPT				
	<b>P5</b>	NONE	1/2" 14 NPT	2.50"		
	<b>P6</b>		3/4" 14 NPT			
	<b>P7</b>	1/2" 14 NPT (FEMALE)	1/2" 14 NPT	3.25"		
	<b>P8</b>		3/4" 14 NPT			
<b>P9</b>	3/4" 14 NPT (FEMALE)	3/4" 14 NPT	3.35"	1-3/8"		
<b>SS</b>	Fitting material: ▼ <b>SS</b> = Stainless steel, type 303 <b>ST</b> = Stainless steel, type 316					
<b>1V130</b>	Grommet hole quantity, material and size:					
	Hole qty.	Material			Grommet hole Ø	Cable/conductor Ø range
		Neo-prene	Fluoro-elastomer			
		1015, 4015	1015, 4015	3015		
	1		▼ <b>1V130</b>		0.130"	0.100" to 0.130"
			▼ <b>1V160</b>	<b>1V160</b>	0.160"	0.130" to 0.160"
			▼ <b>1V220</b>	<b>1V220</b>	0.220"	0.190" to 0.220"
	2	<b>2N130</b>	▼ <b>2V130</b>		0.130"	0.100" to 0.130"
		<b>2N160</b>	▼ <b>2V160</b>		0.160"	0.130" to 0.160"
		<b>2N190</b>	<b>2V190</b>		0.190"	0.160" to 0.190"
<b>2N220</b>		<b>2V220</b>	<b>2V220</b>	0.220"	0.190" to 0.220"	
3	<b>3N130</b>	<b>3V130</b>		0.130"	0.100" to 0.130"	
		<b>3V160</b>		0.160"	0.130" to 0.160"	
	<b>3N190</b>	<b>3V190</b>	▼ <b>3V190</b>	0.190"	0.160" to 0.190"	
4			▼ <b>4V100</b>	0.100"	0.080" to 0.100"	
		▼ <b>4V130</b>	▼ <b>4V130</b>	0.130"	0.100" to 0.130"	
		▼ <b>4V160</b>	▼ <b>4V160</b>	0.160"	0.130" to 0.160"	
6	<b>6N050</b>	▼ <b>6V050</b>	▼ <b>6V050</b>	0.050"	0.030" to 0.050"	
FG1015P1SS1V130 = Sample part number						

## Fitting Body/Cap Only

To configure your fitting body/cap, select from the options listed below to determine the complete part number. Use the code shown in **bold** for each selection. Fitting bodies do not include grommet and compression plugs, and washer.

<b>FG1014</b>	Model number: FG1014: Cable seal fitting body only FG4014: Cable seal fitting body only (ATEX)				
<b>P1</b>	Pipe thread code:				
	Code	Connection thread	Process thread	Overall length	Connection hex size
	<b>P1</b>	1/2" 14 NPT	3/4" 14 NPT	3.25"	1-1/8"
	<b>P2</b>	3/4" 14 NPT			
	<b>P3</b>	1/2" 14 NPT	1/2" 14 NPT		
	<b>P4</b>	3/4" 14 NPT			
	<b>P5</b>	NONE	1/2" 14 NPT	2.50"	
	<b>P6</b>		3/4" 14 NPT		
	<b>P7</b>	1/2" 14 NPT (FEMALE)	1/2" 14 NPT	3.25"	
	<b>P8</b>		3/4" 14 NPT		
<b>P9</b>	3/4" 14 NPT (FEMALE)	3/4" 14 NPT	3.35"	1-3/8"	
<b>SS</b>	Fitting material: <b>SS</b> = Stainless steel, type 303 <b>ST</b> = Stainless steel, type 316				
FG1014P1SS = Sample part number					

### Grommet Kits

To configure your grommet kit, select from the options listed below to determine the complete part number. Use the code shown in **bold** for each selection. Kits include grommet and compression plugs, and washer (1015).

<b>AC1015</b>	Kit type: <b>AC1015</b> = Feed-through grommet <b>AC3015</b> = Split grommet design <b>AC4015</b> = Feed-through grommet, certified <b>AC4015</b> = Split grommet design, certified (add S to end of part number to receive split grommet version)					
<b>H1V130</b>	Grommet hole quantity, material and size:					
	Hole qty.	Material			Grommet hole Ø	Cable/conductor Ø range
		Neo-prene	Fluoro-elastomer			
		1015, 4015	1015, 4015	3015		
	H1		<b>1V130</b>		0.130"	0.100" to 0.130"
			<b>1V160</b>	<b>1V160</b>	0.160"	0.130" to 0.160"
			<b>1V220</b>	<b>1V220</b>	0.220"	0.190" to 0.220"
	H2	<b>2N130</b>	<b>2V130</b>		0.130"	0.100" to 0.130"
		<b>2N160</b>	<b>2V160</b>		0.160"	0.130" to 0.160"
		<b>2N190</b>	<b>2V190</b>		0.190"	0.160" to 0.190"
H3	<b>2N220</b>	<b>2V220</b>	<b>2V220</b>	0.220"	0.190" to 0.220"	
	<b>3N130</b>	<b>3V130</b>		0.130"	0.100" to 0.130"	
		<b>3V160</b>		0.160"	0.130" to 0.160"	
H4	<b>3N190</b>	<b>3V190</b>	<b>3V190</b>	0.190"	0.160" to 0.190"	
			<b>4V100</b>	0.100"	0.080" to 0.100"	
		<b>4V130</b>	<b>4V130</b>	0.130"	0.100" to 0.130"	
H6		<b>4V160</b>	<b>4V160</b>	0.160"	0.130" to 0.160"	
		<b>4V130</b>	<b>4V130</b>	0.130"	0.100" to 0.130"	
	<b>6N050</b>	<b>6V050</b>	<b>6V050</b>	0.050"	0.030" to 0.050"	
AC1015H1V130 = Sample part number						

Specifications subject to change

Note: Order the 6-hole version to seal around PTFE-insulated wires.

# Sealed Elastomer Rubber-filled Cable - Prevent Oil Seepage

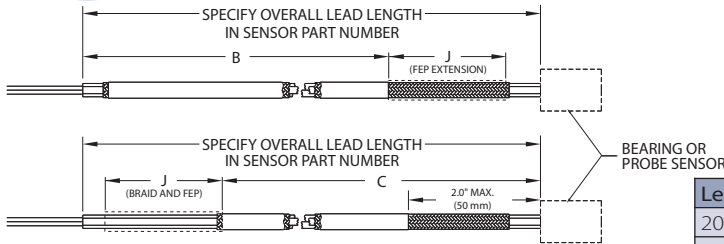
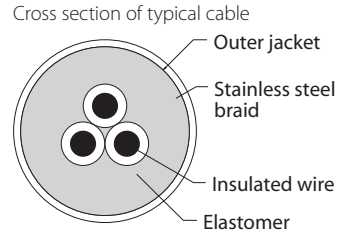

Lead size AWG	Number of leads	Grommet hole Ø
20	2	0.160
24	2	0.130
24	3 and 4	0.160
24	6	0.190
26 - 28	2, 3, 4, and 6	0.130
30	2, 3, and 4	0.100
30	6	0.130

## Overview

Model AC100324 is a sensor cable with elastomer fill between the wires, stainless steel braid, and outer jacket. This fill can extend along the entire length of the cable, or a specified portion. Seal the outside of the cable with an FG1015, FG3015 or FG4015 leadwire and cable seal fitting. See page 3-12 for more information.

While the AC100324 provides a good seal, a minuscule amount of oil may escape inside the individual wires.

## Specifications

**Temperature range:** -50° C to 125°C (-58°F to 257°F).

**Tolerance on lead length:** +1/-0" (+25/-0mm) for lead lengths 24" or less; +5/-0% for lead length greater than 24".

**B length:** Cable is filled starting at leadwire end of cable. Tubing ends at B length; stainless steel braid extends to case.

**C length:** Cable is filled starting 2" from case. If J length is specified, stainless steel braid extends to lead end.

**J length:** Unfilled FEP extension length.

## Using the AC100324 with FG1015/FG3015/FG4015 oil seal fittings

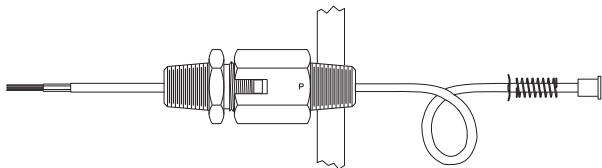

When selecting the FG1015, FG3015 or FG4015 for use with silicone filled cable use the grommet hole size from the tables.

Number of sensing elements	Case style	Grommet hole Ø	
		Leads/RTD	
		2	3
1	A	.130	.160
	B	.130	.160
	C	.130	.130
	D	.100	.100
2	A	.160	.190
	B	.130	.130
	C	.100	.130

Learn more about FG1015, FG3015 or FG4015 leadwire and cable seal fittings on page 3-12.

**Specify elastomer filled cables directly in miniature sensor part numbers on pages 6-2 to 6-9 or add to any sensor as part of an assembly.**

## Specification and order options

AC100324	Model number
B24	Elastomer filled length B or C in inches (if not specified, entire length will be filled) B = Lead end C = Sensor end (Max fill length = 240")
To order standard filled cable, stop here. To order an optional jacket extension add:	
J	Jacket extension
AC100324B24J = Sample part number	

Note: The sensor model number dictates all specifications other than the elastomer filled length B or C and optional extension J. You must specify sensor model including SS braid covering over the leadwires when ordering. Some sensor models do not include the option for SS braid lead covering; contact Minco for assistance with these sensors.

Specifications subject to change

# Extension Wire

## Overview

Use extension wire and cable to connect sensor leadwires to remote instrumentation. Unless informed otherwise, wire and cable will be supplied in continuous lengths. Ends are not stripped.



ACCESSORIES

## Wire for RTDs

Choose single conductor copper wire or cable.

Description	Temperature Limit	Color	Model number for AWG	
			22	26
Single conductor wire, stranded PTFE insulation	260°C (500°F)	White	WS122W	WS126W
		Red	WS122R	WS126R
		Blue	WS122B	WS126B
		Yellow	WS122Y	WS126Y
Single conductor wire, stranded, mica/glass insulation	550°C (1022°F)	White	WS222W	
		Red tracer	WS222R	
3 conductor cable, PTFE insulation, stainless steel braid over all	260°C (500°F)	Red/White/White	WS322S	WS326S
6 conductor cable, PTFE insulation, stainless steel braid over all	260°C (500°F)	Red/White/White/Blue/Yellow/Yellow		WS426S
3 conductor cable, PTFE insulation, copper shield and PTFE jacket over all	260°C (500°F)	Red/White/White	WS522T	

## Specification and order options

WS122R	Model number from table
10	Length in feet
WS122R10 = Sample part number	

## Single Pair Thermocouple Cable

All thermocouple wire meets standard limits of error per NBS (NIST) Monograph 175, based on ITS-90.

Description	Temperature Limit	Model number for AWG	
		20	24
Single pair thermocouple cable, glass braid insulation	482°C (900°F)	WT120G	WT124G
Single pair thermocouple cable, PTFE insulation	260°C (500°F)	WT120T	WT124T
Single pair thermocouple cable, glass braid insulation with stainless steel braid over all	482°C (900°F)	WT120S	WT124S

## Specification and order options

WT120S	Model number from table
J	Junction type: E, J, K, or T
25	Length in feet
WT120SJ25 = Sample part number	

▼ = STANDARD OPTIONS  
Specifications subject to change







## ► SECTION 4: INSTRUMENTS

- RTD and thermocouple Temptran™ transmitters provide accurate signals over thousands of feet.
  - Fixed range, dip switch field rangeable or programmable
  - 4-20mA output or HART® protocol
  - Miniature, hockey puck, DIN rail and isolated versions
  - High-accuracy calibration available matched to individual RTDs
  - Controllers, indicators and alarms for precise monitoring and control

RTD transmitters.....	4-2 to 4-5, 4-8 to 4-9,	CT24 12-channel monitor.....	4-25 to 4-26
.....	4-12 to 4-13	CT424 alarm/monitor.....	4-27 to 4-28
Thermocouple transmitters.....	4-6 to 4-7, 4-10 to 4-11,	CT325 miniature DC temperature controller.....	4-29 to 4-30
.....	4-14 to 4-15	CT335 PC board mount temperature controller.....	4-31 to 4-32
Programmable transmitters.....	4-8 to 4-11	CT435 PC board mount temperature controller.....	4-33 to 4-34
Field rangeable transmitters.....	4-12 to 4-15	CT15 controller/alarm.....	4-35 to 4-36
Programmable transmitters.....	4-16 to 4-17	CT16A temperature controller.....	4-37 to 4-38
HART® transmitters.....	4-18 to 4-19	CT15/CT16A accessories.....	4-39
Temperature range table.....	4-20 to 4-21	CT425 Temperature Controller.....	4-40 to 4-41
High accuracy calibration.....	4-22		
Mounting accessories.....	4-22		
Loop-powered indicators.....	4-23 to 4-24		

# Miniature Temptran™ RTD Transmitters



## Overview

- Two models:  
 TT111: UL-recognized component for Canada and United States.  
 TT211: Wider ambient rating; Factory Mutual (FM) approved intrinsically safe and nonincendive.
- Optional high-accuracy calibration to Minco RTDs for improved accuracy; see next page and page 4-22 for more information.

## Specifications

**Output:** 4 to 20 mA over specified range, linear with temperature.

**Calibration accuracy:** ±0.1% of span.

**Linearity:** Referenced to actual sensor temperature.

Platinum RTD input: ±0.1% of span.

Nickel and nickel-iron RTD input:

±0.25% of span for spans less than 100°C.

±0.25% of span per 100°C of span for spans greater than 100°C.

**Adjustments:** Zero and span, ±5% of span. Factory set.

### Ambient temperature:

TT111: 0 to 50°C (32 to 122°F).

TT211: -25 to 85°C (-13 to 185°F).

Storage: -55 to 100°C (-67 to 212°F).

### Ambient temperature effects:

±0.013% of span per °C.

±0.025% of span per °C for spans less than 55°C.

### Warmup drift: ±0.1% of span max., with

$V_{supply} = 24$  VDC and  $R_{loop} = 250 \Omega$ .

Stable within 30 minutes.

**Supply voltage:** 8.5 to 35 VDC. Voltage effect ±0.001% of span per volt. Reverse polarity protected.

**Maximum load resistance:** The maximum allowable resistance of the signal carrying loop is:

$$R_{loop\ max} = \frac{V_{supply} - 8.5}{0.020\ \text{amps}}$$

Example: With supply voltage 24 VDC, maximum loop resistance is 775  $\Omega$ .

**Minimum span:** 27.8°C (50°F).

**Hazardous atmospheres:** All models may be used with Minco flameproof/explosionproof connection heads. Models TT211 is Factory Mutual approved nonincendive for use in Class I, Division 2 areas and intrinsically safe for Class I, Division 1 areas (requires approved barrier). Transmitter entity parameters:

$V_{max} = 35$  volts;  $I_{max} = 150$  mA;  $C_i = 0$   $\mu$ F and  $L_i = 0$  mH.

### Connections:

Terminal block for wires AWG 22 to AWG 14.

**Physical:** Polycarbonate case, epoxy potted for moisture resistance.

**Weight:** 1.1 oz. (30 g).

## Hazardous area requirements

For more information on how to classify a hazardous area, methods of protection, and the various standards and agencies (including FM, CSA, CENELEC, IECEx and ATEX), visit [www.minco.com](http://www.minco.com).

▼ = STANDARD OPTIONS  
 Specifications subject to change



# Miniature RTD Transmitters

## RTD input types

2-wire resistance thermometer:

Element		Code
Platinum (0.00392 TCR)	100 $\Omega$ at 0°C	PA
Platinum (0.00391 TCR)	100 $\Omega$ at 0°C	PB
Platinum (0.00385 TCR)	100 $\Omega$ at 0°C	PD, PE
Platinum (0.00385 TCR)	1000 $\Omega$ at 0°C	PF
Platinum (0.00375 TCR)	1000 $\Omega$ at 0°C	PW
Nickel-iron (0.00518 TCR)	604 $\Omega$ at 0°C	FA
Nickel-iron (0.00527 TCR)	1000 $\Omega$ at 70°F	FB
Nickel-iron (0.00527 TCR)	2000 $\Omega$ at 70°F	FC
Nickel (0.00672 TCR)	120 $\Omega$ at 0°C	NA

## Special high-accuracy calibration

For high system accuracy, specify transmitters with matched calibration. Temptrans match calibrated to a sensor are always ordered as assemblies. Common examples are shown in Section 1.

## Specification and order options:

TT111	Model number: TT111 or TT211
PD	RTD element code from table
1	Output: 4 to 20 mA DC
C	Temperature range code starting on page 4-20 [Ex: C = 0 to 100°C (32 to 212°F)]
TT111PD1C = Sample part number	

INSTRUMENTS

## Dimensions in inches (mm)

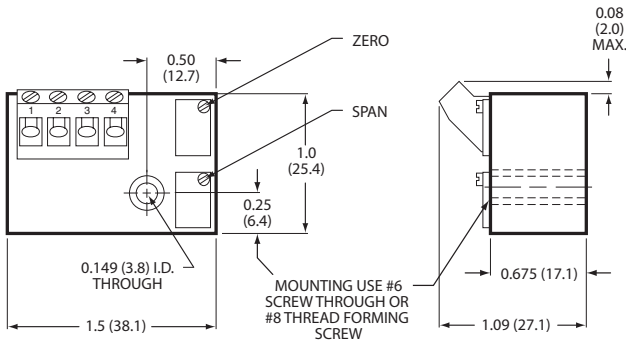

## Wiring Diagram

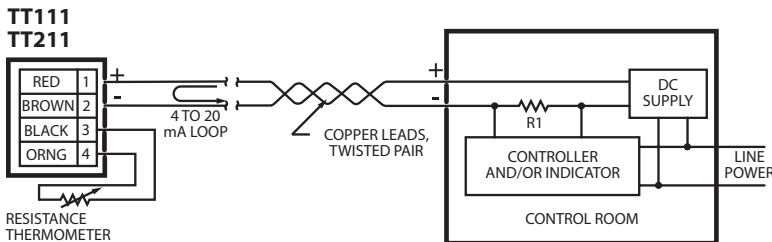

▼ = **STANDARD OPTIONS**  
Specifications subject to change

# TT246 RTD Transmitters



TT246 RTD Transmitter,  
voltage output

## Overview

Specify this rugged, accurate transmitter for process control and other industrial applications.

Model TT246 outputs 1 to 5 VDC proportional to temperature. It draws only 3 mA of quiescent current, making it ideal for solar or battery powered systems.

- 2 or 3-wire RTD input
- Ambient rated to 85°C (185°F)
- Fits DIN "B" style connection heads
- Optional high-accuracy calibration to Minco RTDs for improved accuracy; see next page and page 4-22 for more information.

## Specifications

**Output:** Linear with temperature over specified range.  
TT246: 1 to 5 VDC

**Calibration Accuracy:** ±0.1% of span (0.2% of span for spans less than 10 Ω)

**Linearity:** 0.1% of span, referenced to actual sensor temperature

**Adjustments** Zero and span, ±5% of span, non-interacting. Factory set.

### Ambient temperature:

Operating: -40 to 85°C (-40 to 185°F)

Storage: -55 to 100°C (-67 to 212°F)

### Ambient temperature effects:

±0.009% of span per °C

±0.014% of span per °C for spans less than 10 Ω

### Warmup drift:

±0.1% of span max., with  $V_{supply} = 24$  VDC and  $R_{loop} = 250$  Ω.  
Stable within 15 minutes.

### Supply voltage:

TT246: 7.5 to 35 VDC

Voltage effect ±0.001% of span per volt.

Reverse polarity protected.

**Supply current:** 3mA max. with no load.

**Maximum load resistance:** The maximum allowable resistance of the signal carrying loop is:

$$R_{loop\ max} = \frac{V_{supply} - 10}{0.020\ \text{amps}}$$

Example: With supply voltage 24 VDC, maximum loop resistance is 700 Ω.

**Minimum span:** 10°C (18°F).

**Minimum output current:** 2.2 mA.

**Maximum output current:** 28 mA.

**Leadwire compensation:** (3-wire RTD) ±0.05% of span per Ω up to 25 Ω in each leg.

**Hazardous atmospheres:** May be used with Minco explosion-proof connection heads.

**Connections:** Terminal block for wires AWG 22 to AWG 14.

**Physical:** Polycarbonate case, epoxy potted for moisture resistance.

**Weight:** 2.0 oz. (57 g).

▼ = **STANDARD OPTIONS**

Specifications subject to change

## RTD input types

2 or 3-wire resistance thermometer:

Element		Code
Platinum (0.00392 TCR)	100 $\Omega$ at 0°C	PA
Platinum (0.00391 TCR)	100 $\Omega$ at 0°C	PB
Platinum (0.00385 TCR)	100 $\Omega$ at 0°C	PD, PE
Platinum (0.00385 TCR)	1000 $\Omega$ at 0°C	PF
Platinum (0.00375 TCR)	1000 $\Omega$ at 0°C	PW
Copper (0.00427 TCR)	10 $\Omega$ at 25°C	CA
Nickel-iron (0.00518 TCR)	604 $\Omega$ at 0°C	FA
Nickel-iron (0.00527 TCR)	1000 $\Omega$ at 70°F	FB
Nickel-iron (0.00527 TCR)	2000 $\Omega$ at 70°F	FC
Nickel (0.00672 TCR)	120 $\Omega$ at 0°C	NA

## Special high-accuracy calibration

For high system accuracy, specify transmitters with matched calibration. Temptrans match calibrated to a sensor are always ordered as assemblies.

## Specification and order options:

TT246	Model Number:
PB	RTD element code from table
1	
K	Temperature range code starting on page 4-20 [Ex: K = 0 to 200°C (32 to 392°F)]
TT246PB1K = Sample part number	

## Dimensions in inches (mm)

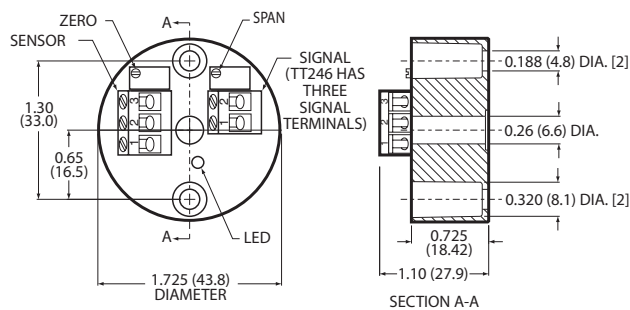

## Wiring Diagram

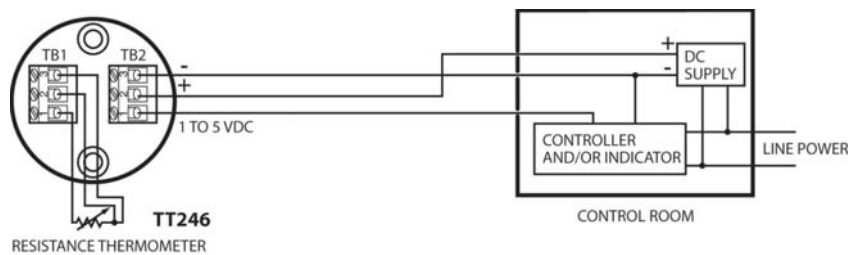

▼ = **STANDARD OPTIONS**  
Specifications subject to change

# TT205 Thermocouple Transmitters



TT205  
Thermocouple Transmitter

## Overview

Model TT205 interfaces with thermocouples for use in process control and other industrial applications.

Model TT205 offers superior performance in an economical and small package.

- Thermocouple input
- Fits DIN "B" style connection heads

## Specifications

**Output:** 4 to 20 mA over specified range.

**Accuracy:** ±0.2% of span.

**Linearity:** Voltage linear.

The output signal is voltage linear (not temperature linear) and is intended for use with instruments which compensate for the nonlinear signal output of the thermocouples sensor.

**Adjustments:** Zero and span, ±5% of span, non-interacting. Factory set.

**Warmup drift:** ±0.2% of span max., with  $V_{supply} = 24$  VDC and  $R_{loop} = 250 \Omega$ .  
Stable within 15 minutes.

**Supply voltage:** 8.5 to 35 VDC  
Voltage effect ±0.001% of span per volt.  
Reverse polarity protected.

**Maximum load resistance:** The maximum allowable resistance of the signal carrying loop is:

$$R_{loop\ max} = \frac{V_{supply} - 10}{0.020\ \text{amps}}$$

Example: With supply voltage 24 VDC, maximum loop resistance is 700  $\Omega$ .

**Minimum output current:** 1.5 mA.

**Maximum output current:** 28 mA.

**Burnout:** Downscale burnout standard; upscale optional.

**Connections:** Terminal block for wires AWG 22 to AWG 14.

**Physical:** Polycarbonate case, epoxy potted for moisture resistance.

**Weight:** 1.8 oz. (52 g).

▼ = STANDARD OPTIONS  
Specifications subject to change

## TT205

### Ambient temperature:

Operating: -10 to 60°C (14 to 140°F).

Storage: -55 to 100°C (-67 to 212°F).

Ambient temperature effects:  $\pm 0.036\%$  of span per °C.

Cold junction compensation drift:  $\pm 0.05^\circ\text{C}$  per °C.

Minimum span: 150°C (270°F).

## Specification and order options

TT205	Model Number: TT190: Round TT205: Rectangular
J	TC junction type: E = Chromel-Constantan J = Iron-Constantan K = Chromel-Alumel T = Copper-Constantan
U	U = Ungrounded junction (required)
1	Output: 4 to 20 mA DC
AN	Temperature range code starting on page 4-20 [Ex: AN = -17.8 to 148.9°C (0 to 300°F)]
TT205JU1AN = Sample part number	

## TT205 Dimensions in inches (mm)

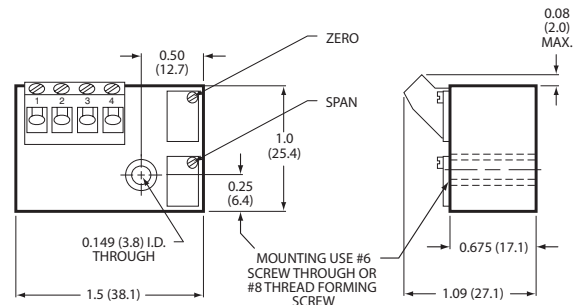

## Wiring Diagram

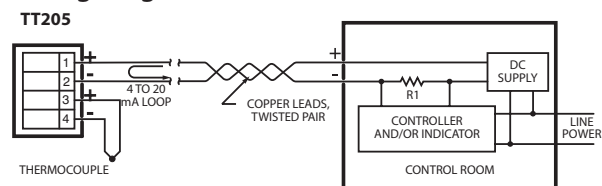

▼ = STANDARD OPTIONS  
Specifications subject to change

# TT508/TT518 Programmable Temperature Transmitter

## Overview

This transmitter amplifies a signal from a RTD or linear resistance, and it turns the signal into a current which increases from 4 to 20 milliamperes as the temperature or input signal increases. This industry-standard 4-20mA signal travels thousands of feet over a pair of wires, ignoring electrical interference and bringing the temperature, accurately, into your computer or controller. Drawing power directly from the signal line, only 2 wires are needed for power and signal.

- RTD or Ohm input
- Accurate, Stable 4–20mA Output
- PC and field-programmable
- FM Approved Intrinsically Safe

## Converts multiple inputs

Temperature measurement can be done with one of several RTD's: 100  $\Omega$ , 1000  $\Omega$  platinum, 100  $\Omega$  Nickel and 1000  $\Omega$  Nickel.

Because amplification and conversion of the input signal is performed within a few feet of the sensor, electrical interference in noisy environments is eliminated. The transmitter can be mounted at the field location in a standard DIN form B head or on a DIN rail inside a local box.

## Applications

- Single temperature measurement

## Configuration

The TT508/TT518 is delivered configured to the customer's specifications, including the transmitter's measurement range and RTD type.

## PC Programming

The TT508/TT518 transmitter can be configured via a standard PC using a programming kit. It can be configured before installation or while installed in the process - even in hazardous areas. Communication is 2-way, so set-up and serial/tag numbers can be retrieved from the transmitter.



## Specifications

**Ambient temperature range:** -40°C to +85°C

**Supply voltage:** 8 -30 VDC

**Warm-up time:** 5 min.

**Communication interface:** PC Interface/Loop Link

**Signal/noise ratio:** Min. 60 dB

**Response time (programmable):** 0.33 sec. to 60 sec.

**Update time:** 135 msec.

**Calibration temperature:** 20 to 28°C

**Effect of supply voltage change:** < 0.005% of span/ VDC

**EMC-Immunity influence:** <  $\pm 0.5\%$  of span

**Vibration:** IEC 600 68-2-6 Test FC

**Lloyd's specification no. 1:** 4 g / 2 - 100 Hz

**Max. wire size:** AWG14 (1.5 mm<sup>2</sup>)

**Air humidity:** 0 - 95% RH

**Dimensions:**  $\varnothing 1.73 \times 0.84$  in ( $\varnothing 44 \times 20.2$ mm)

**Tightness (enclosure/terminal):** IP 68 / IP00

**Weight:** 50g

▼ = **STANDARD OPTIONS**  
Specifications subject to change

## Inputs (common specifications)

**Max. offset:** 50% of selected max. value

**Cable resistance per wire (max.):** 10Ω

**Sensor current:** >0.2mA, <0.4mA

**Effect of sensor cable resistance:**  
(3-wire): < 0.002 Ω/Ω

### Input:

Type	Minimum Value	Maximum Value	Minimum Span
PD (Pt100)	-200°C	+850°C	25°C
PF (Pt1000)	-200°C	+850°C	25°C
Linear Res.	0 Ω	10000 Ω	30 Ω

### Basic accuracy:

PD/PF (Pt100/1000): <±0.3°C  
Linear Resistance: <±0.2Ω

### Temperature coefficient:

PD/PF (Pt100/1000): <±0.01°C/°C  
Linear Resistance: <±20mΩ/°C

### Current output:

Signal range: 4 - 20 mA  
Min. signal range: 16 mA  
Load resistance : < (V<sub>sup.</sub> - 8) / 0.023 [Ω]  
Load stability: ± 0.01% of span / 100 Ω

### Sensor error detection:

Programmable: 3.5 - 23 mA, or no action  
Namur NE43 Downscale/Upscale: 3.5 mA/ 23 mA

### Approvals:

EMC: EN 61326-1  
ATEX.: KEMA 03ATEX1535  
FM: 2D5A7  
CSA: 1125003  
GOST R: Yes  
GOST Ex: Yes  
DNV Marine: Stand. F. Certification No. 2.4

## Input

The input type is selected to be one of these types:

- RTD (2 or 3-wire): PT100, PT1000

## Output

The 4-20 mA output follows the TT518 input configuration, reflecting the temperature and/or resistance. The unit is protected against polarity reversal. The output signal action can be reversed with respect to the input signal. Sensor and/or cable errors can be programmed to cause the output to go to a fixed value.

## Specification and order options:

TT518	<b>Model Number:</b> TT518 Approvals, fits .236" Probe Max TT508 No Approvals, fits .250" Probe Max
PD	<b>Sensor Type:</b> PD = 100 Ω Platinum RTD (0.00385) PF = 1000 Ω Platinum RTD (0.00385)
(-25/200)	<b>Ranging:</b> Specify temperature range in either °C or °F. For example, -25° to +200°C = 4 to 20 mA.
C	<b>Display Units:</b> C = Celsius F = Fahrenheit
1	<b>Calibration:</b> 1 = Nominal 2 = Matched to sensor ±0.75% of span For other calibration options, contact Minco
Z	<b>Sensor Leads: (3 Lead Recommended)</b> Y = 2-lead RTD (Supplied with jumper wire to connect terminals 3 and 4) Z = 3-lead RTD
TT518PD(-25/200)C1Z : Sample part number	

*Note: TT508 does not carry any external approvals, but does allow a .250" probe to pass through its center hole*

▼ = **STANDARD OPTIONS**  
Specifications subject to change

# TT509/TT519 Programmable Temperature Transmitter

## Overview

This transmitter amplifies a signal from a thermocouple, and it turns the signal into a current which increases from 4 to 20 milliamperes as the temperature or input signal increases. This industry-standard 4-20mA signal travels thousands of feet over a pair of wires, ignoring electrical interference and bringing the temperature, accurately, into your computer or controller. Drawing power directly from the signal line, only 2 wires are needed for power and signal.

- Thermocouple or Voltage Input
- Accurate, Stable 4–20mA Output
- PC and field-programmable
- Galvanically Isolated

## Converts multiple inputs

Temperature measurement can be done with multiple thermocouple types, which boast high operating temperature ranges.

Because amplification and conversion of the input signal is performed within a few feet of the sensor, electrical interference in noisy environments is eliminated. The transmitter can be mounted at the field location in a standard DIN form B head or on a DIN rail inside a local box.

## Applications

- Single temperature measurement

## Configuration

The TT509/TT519 is delivered configured to the customer's specifications, including the transmitter's measurement range and thermocouple type.

## PC programming

The TT509/TT519 transmitter can be configured via a standard PC using a programming kit. It can be configured before installation or while installed in the process - even in hazardous areas. Communication is 2-way, so set-up and serial/tag numbers can be retrieved from the transmitter.



## Specifications

**Ambient temperature range:** -40°C to +85°C

**Supply voltage:** 7.2 -30 VDC

**Warm-up time:** 5 min.

**Communication interface:** PC Interface/Loop Link

**Signal/noise ratio:** Min. 60 dB

**Response time (programmable):** 1 sec. to 60 sec.

**Update time:** 440 msec.

**Calibration temperature:** 20 to 28°C

**Effect of supply voltage change:** < 0.005% of span/ VDC

**EMC-Immunity influence:** < ±0.5% of span

**Electrical Isolation, test/operation:** 1.5kVAC/50VAC

**Vibration:** IEC 600 68-2-6 Test FC

**Lloyd's specification no. 1:** 4 g / 2 - 100 Hz

**Max. wire size:** AWG14 (1.5 mm<sup>2</sup>)

**Air humidity:** 0 - 95% RH

**Dimensions:** ∅1.73 x 0.84 in (∅44 x 20.2mm)

**Tightness (enclosure/terminal):** IP 68 / IP00

**Weight:** 50g

▼ = **STANDARD OPTIONS**  
Specifications subject to change



## Inputs (common specifications)

Max. offset: 50% of selected max. value

Input:

Type	Minimum Value	Maximum Value	Minimum Span
E	-100°C	+1000°C	50°C
J	-100°C	+1200°C	50°C
K	-180°C	+1372°C	50°C
T	-200°C	+400°C	50°C
B	+400°C	+1820°C	100°C
N	-180°C	+1300°C	50°C
R	-50°C	+1760°C	100°C
S	-50°C	+1760°C	100°C

### Basic accuracy:

TC type E, J, K, L, N, T:  $<\pm 1^{\circ}\text{C}$

TC type B, R, S:  $<\pm 2^{\circ}\text{C}$

Voltage:  $\leq \pm 10\mu\text{V}$

### Temperature coefficient:

TC type E, J, K, T:  $<\pm 0.05^{\circ}\text{C}/^{\circ}\text{C}$

TC type B, N, R, S:  $<\pm 0.2^{\circ}\text{C}/^{\circ}\text{C}$

Voltage:  $<\pm 1\mu\text{V}/^{\circ}\text{C}$

Cold Junction Compensation:  $<\pm 1^{\circ}\text{C}$

### Current output:

Signal range: 4 - 20 mA

Min. signal range: 16 mA

Load resistance :  $< (V_{\text{sup}} - 7.2) / 0.023 [\Omega]$

Load stability:  $\pm 0.01\%$  of span / 100  $\Omega$

### Sensor error detection:

Programmable: 3.5 - 23 mA, or no action

Namur NE43 Downscale/Upscale: 3.5 mA/ 23 mA

### Approvals:

EMC: EN 61326-1

ATEX.: KEMA 06ATEX0062

GOST R: Yes

GOST Ex: Yes

DNV Marine: Stand. F. Certification No. 2.4

## Input

The input type is selected to be one of these types:

- Type E, J, K, T, B, N, R, S Thermocouple
- Voltage Input

## Output

The 4-20 mA output follows the TT519 input configuration, reflecting the temperature. The unit is protected against polarity reversal. The output signal action can be reversed with respect to the input signal. Sensor and/or cable errors can be programmed to cause the output to go to a fixed value.

### Specification and order options:

TT519	Model Number: TT519 Approvals, fits .236" Probe Max TT509 No Approvals, fits .250" Probe Max
K	Sensor Type: E=Type E Thermocouple J=Type J Thermocouple K=Type K Thermocouple T=Type T Thermocouple B=Type B Thermocouple N=Type N Thermocouple R=Type R Thermocouple S=Type S Thermocouple V = Voltage Input
(-25/200)	Ranging: Specify temperature range in either °C or °F. For example, -25° to +200°C = 4 to 20 mA.
C	Display Units: C = Celsius F = Fahrenheit MV = Millivolts
1	Calibration: 1 = Nominal
Y	Sensor Leads: Y = 2-lead
TT519K(-25/200)C1Y: Sample part number	

Note: TT509 does not carry any external approvals, but does allow a .250" probe to pass through its center hole

▼ = STANDARD OPTIONS

Specifications subject to change

# TT273 Field Rangeable RTD Temperature Transmitter



TT273 RTD  
Temperature Transmitter

## Overview

Model TT273 is a 2-wire temperature transmitter for 2 or 3-lead 100 Ω platinum RTDs. The transmitter converts the RTD temperature into a linearized 4 to 20 mA DC current signal. Because this current signal is immune to leadwire and electrical noise, the TT273 lets you obtain accurate temperature readings from RTDs thousands of feet away. An ordinary twisted pair of wires carries both the temperature signal and power for the transmitter's electronics.

An LED conveniently indicates the status of the control loop. The brightness is directly proportional to the loop current. A very bright LED indicates an open RTD; a dark LED signals a shorted RTD or loss of current loop power.

- 4 to 20 mA current signal
- Fits standard 35 mm DIN rail
- Field-calibrate to your temperature range
- Optional high-accuracy calibration to Minco RTDs for improved accuracy; see next page and page 5-22 for more information
- Optional Input/Output isolation to 600 VRMS

## Specifications

**Output:** 4 to 20 mA DC over specified range.

**Calibration accuracy:** ±0.2% of span.

**Linearity:** ±0.2% of span, reference to actual sensor temperature.

### Adjustments:

Zero: -50 to 150°C (-58 to 302°F).

Span: 50 to 600°C (90 to 1080°F).

### Ambient temperature:

Operating: -40 to 85°C (-40 to 185°F).

Storage: -55 to 100°C (-67 to 212°F).

### Ambient temperature effects:

±0.018% of span/°C (±0.01% of span/°F).

### Warmup drift:

±0.1% of span max., assuming

$V_{supply} = 24$  VDC and  $R_{loop} = 250$  Ω.

Stable within 15 minutes.

**Input/output isolation (optional):** 600 VRMS, 1 minute.

### Supply voltage:

Non-Isolated: 10 to 45 volts DC with no load.

Isolated: 13 to 45 volts DC with no load.

Reverse polarity protected.

**Voltage effect:** ±0.001% of span per volt.

### Lead wire compensation: (3-wire RTD)

±0.05% of span per Ω, up to 25 Ω in each leg.

**Maximum load resistance:** The maximum allowable resistance of the signal-carrying loop is given by this formula:

$$\text{Non-Isolated: } R_{loop\ max} = \frac{V_{supply} - 10}{0.020\ \text{amps}}$$

$$\text{Isolated: } R_{loop\ max} = \frac{V_{supply} - 13}{0.020\ \text{amps}}$$

**Maximum output current:** 28 mA.

**Connections:** Terminal block accepts wires from AWG 22 to AWG 14.

**Physical:** Polycarbonate, DIN rail enclosure.

**Weight:** 4.2 oz. (119 g).

▼ = **STANDARD OPTIONS**

Specifications subject to change

## RTD input types

2 or 3-wire 100  $\Omega$  platinum RTD.

Element		Code
Platinum (0.00392 TCR)	100 $\Omega$ at 0°C	PA
Platinum (0.00391 TCR)	100 $\Omega$ at 0°C	PB
Platinum (0.00385 TCR)	100 $\Omega$ at 0°C	PD, PE

## Special high-accuracy calibration

For high system accuracy, specify transmitters with matched calibration. Temprans match calibrated to a sensor are always ordered as assemblies. Common examples are shown in Section 1.

## Specification and order options

TT273	Model number
PD	RTD element code from table
1	Output: 4 to 20 mA DC
N	Input/Output: N = Non-isolated I = Isolated
(-25/50)	Factory preset temp. range: (4 mA/20 mA temperature) Range is user adjustable. Refer to the Zero and Span specifications.
C	Temperature scale: F = Fahrenheit C = Celsius
TT273PD1N(-25/50)C = Sample part number	

## Dimensions in inches (mm)

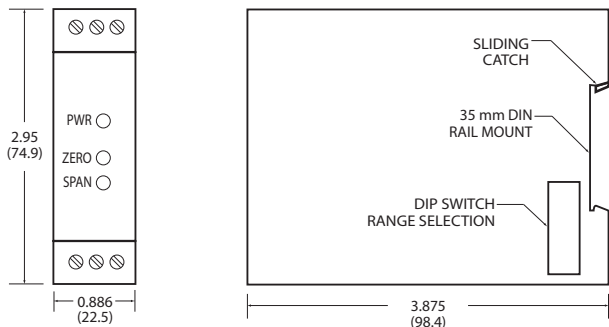

## Wiring diagram

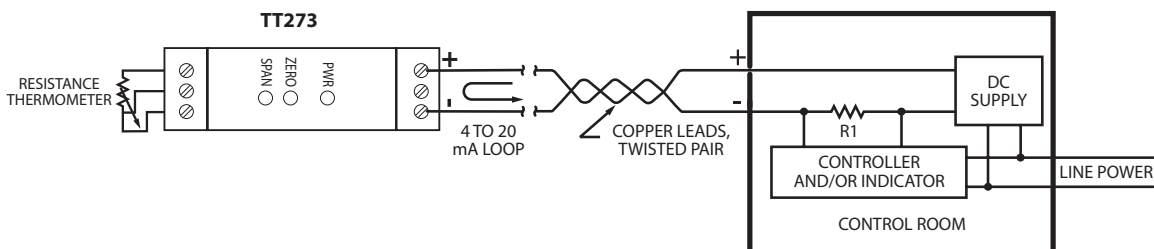

▼ = **STANDARD OPTIONS**  
Specifications subject to change

# TT274 Field Rangeable Thermocouple Temperature Transmitter

## Overview

Model TT274 is a 2-wire temperature transmitter for types J and K thermocouples. The transmitter converts the thermocouple's millivolt signal to a 4 to 20 mA DC current signal. Because this current signal is immune to leadwire and electrical noise, the TT274 lets you obtain accurate temperature readings from thermocouples thousands of feet away. An ordinary twisted pair of wires carries both the temperature signal and power for the transmitter's electronics.

With the isolation option, the mV input signal from the thermocouple is electrically isolated from the 4 to 20 mA output, allowing use of grounded thermocouples with multiple TT274s operating from the same power supply.

An LED conveniently indicates the status of the control loop. The brightness is directly proportional to the loop current. A dark LED signals an open sensor or loss of current loop power.

- 4 to 20 mA current signal
- Fits standard 35 mm DIN rail
- Field-calibrate to your thermocouple type and temperature range
- Optional Input/Output isolation to 600 VRMS

## Specifications

**Input:** Type J or K thermocouple (field selectable).

**Output:** 4 to 20 mA DC over specified range.

**Accuracy:**  $\pm 0.2\%$  of span.

**Linearity:** Voltage linear.

The output signal of the TT274 is voltage linear (not temperature linear) and is intended for use with instruments which compensate for the nonlinear signal output of the thermocouple sensor.

### Adjustments:

Zero:  $-50^{\circ}\text{C}$  to  $150^{\circ}\text{C}$  ( $-58^{\circ}\text{F}$  to  $302^{\circ}\text{F}$ ).

Span: Type J: 125 to  $850^{\circ}\text{C}$  (225 to  $1530^{\circ}\text{F}$ ).

Type K: 150 to  $1200^{\circ}\text{C}$  (270 to  $2160^{\circ}\text{F}$ ).



TT274 Thermocouple Temperature Transmitter

### Ambient temperature:

Operating:  $-40$  to  $85^{\circ}\text{C}$  ( $-40$  to  $185^{\circ}\text{F}$ ).

Storage:  $-55$  to  $100^{\circ}\text{C}$  ( $-67$  to  $212^{\circ}\text{F}$ ).

**Ambient temperature effects:**  $\pm 0.036\%$  of span/ $^{\circ}\text{C}$  ( $\pm 0.02\%$  of span/ $^{\circ}\text{F}$ ).

**Cold junction compensation drift:**  $\pm 0.03^{\circ}\text{C}/^{\circ}\text{C}$  for  $-25$  to  $70^{\circ}\text{C}$  ambients.  $\pm 0.06^{\circ}\text{C}/^{\circ}\text{C}$  for  $-40$  to  $-25^{\circ}\text{C}$  and  $70$  to  $85^{\circ}\text{C}$  ambients.

**Warmup drift:**  $\pm 0.1\%$  of span max., assuming

$V_{\text{supply}} = 24$  VDC and  $R_{\text{loop}} = 250 \Omega$ .

Stable within 15 minutes.

**Input/output isolation (optional):** 600 VRMS, 1 minute.

### Supply voltage:

Non-Isolated: 10 to 45 volts DC with no load.

Isolated: 13 to 45 volts DC with no load.

Reverse polarity protected.

**Voltage effect:**  $\pm 0.001\%$  of span per volt.

**Maximum load resistance:** The maximum allowable resistance of the signal-carrying loop is given by this formula:

$$\text{Non-Isolated: } R_{\text{loop max}} = \frac{V_{\text{supply}} - 10}{0.020 \text{ amps}}$$

$$\text{Isolated: } R_{\text{loop max}} = \frac{V_{\text{supply}} - 13}{0.020 \text{ amps}}$$

**Maximum output current:** 28 mA.

**Connections:** Terminal block accepts wires from AWG 22 to AWG 14.

**Physical:** Polycarbonate, DIN rail enclosure.

**Weight:** 4.2 oz. (119 g).

▼ = **STANDARD OPTIONS**  
Specifications subject to change

## Specification and order options

TT274	Model number
K	T/C element code J = Type J thermocouple K = Type K thermocouple
1	Output: 4 to 20 mA DC
N	Input/Output: N = Non-isolated I = Isolated
(-25/200)	Factory preset temp. range: (4 mA/20 mA temperature) Range is user adjustable. Refer to the Zero and Span specifications.
C	Temperature scale: F = Fahrenheit C = Celsius
TT274K1N(-25/200)C = Sample part number	

## Dimensions in inches (mm)

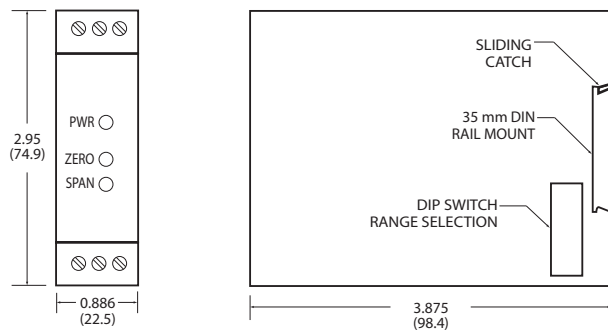

## Wiring diagram

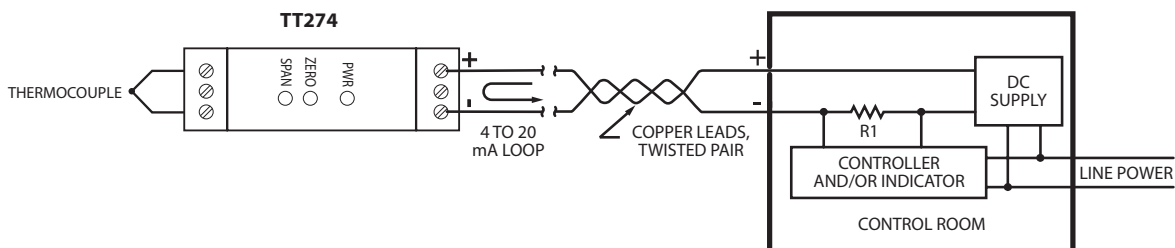

Specifications subject to change

# Programmable Transmitters

## Overview

Models TT520 and TT530 are programmable transmitters designed for process control and other applications. Both transmitters use a 4-20mA current loop output and are PC programmable to accept a signal from a thermocouple, a Resistance Temperature Detector (RTD), or a millivolt signal. Model TT520 can be mounted at the field location in a standard DIN form B head or on a DIN rail inside a local box (with an AC807 Minco DIN rail adapter), whereas model TT530 can be mounted vertically or horizontally on a DIN rail.

- T/C, RTD, or mV input
- Accurate, Stable 4-20mA Output
- PC and field-programmable
- Galvanically isolated
- FM Approved Intrinsically Safe
- Single temperature measurement

## Specifications

### Common Specifications:

**Supply voltage:** 7.2 - 30 VDC

**Temperature coefficient:**  $\pm 0.01\%$  of span/ °C

**Effect of supply voltage change:**  $< 0.005\%$  of span/ VDC

**Max. wire size:** AWG14 (1.5 mm<sup>2</sup>)

**Air humidity:** 0 - 95% RH

### Dimensions:

TT520: Ø1.73 x 0.84 in (Ø44 x 20.2mm)

TT530: 4.29 x .093 x 4.09 in (109 x 23.5 x 104mm)

### AC205817 USB Loop Link Programmer:

TT520 and TT530 transmitters are preconfigured for ease of use. The AC205817 USB Loop Link Programmer allows the user to reconfigure the transmitter using free, Windows-based software.

### Tightness (enclosure/terminal):

TT520: IP 68 / IP00

TT530: IP50 / IP20

### Weight:

TT520: 50 g

TT530: 145 g



TT520



TT530

### TC Input:

#### Minimum measurement range:

Type E, J, K, T: 50°C

Max. offset: 50% of selected max. value

#### Basic accuracy:

Type E, J, K, T:  $\leq 1^\circ\text{C}$

Cold junction compensation (CJC):  $\leq 1.0^\circ\text{C}$

#### Temperature coefficient:

Type E, J, K, T:  $\leq \pm 0.05^\circ\text{C} / ^\circ\text{C}_{\text{amb}}$

Sensor error detection: yes

RTD type	Minimum value	Maximum value	Minimum span.
PD (Pt100)	-200°C	+850°C	25°C
PF (Pt1000)	-200°C	+850°C	25°C

### RTD-input:

Basic accuracy PD/PF (Pt100/1000):  $\leq \pm 0.2^\circ\text{C}$

Temperature coefficient:  $\leq \pm 0.01^\circ\text{C} / ^\circ\text{C}$

### Current output:

Signal range: 4 - 20 mA

Load resistance:  $< (V_{\text{sup}} - 7.2) / 0.023 [\Omega]$

**Intrinsic Safety data:** FM Approved Intrinsically Safe for Class 1, Div. 1, Groups A-D, Entity Approval (pending)

$V_{\text{max}}$ : 30.0 VDC

$C_i$ : 1 nF

$I_{\text{max}}$ : 120 mA DC

$L_i$ : 10  $\mu\text{H}$

$P_{\text{max}}$ : 0.84 W

Europe: ATEX II 1 G

### Meets these European requirements:

EMC 2004/108/EC: Standard EN 61326

▼ = STANDARD OPTIONS

Specifications subject to change

### Specifications and order options

TT520	<b>Model Number:</b> TT520 Temperature Transmitter TT530 DIN Rail Temperature Transmitter
PD	<b>Sensor Type:</b> PD = 100Ω Platinum RTD (0.00385) PF = 1000Ω Platinum RTD (0.00385) E = Type E Thermocouple J = Type J Thermocouple K = Type K Thermocouple T = Type T Thermocouple
(-25/200)	<b>Temperature Range:</b> Specify temperature range in either °C or °F. For example, -25° to +200°C = 4 to 20 mA.
C	<b>Temperature Units:</b> C = Celsius F = Fahrenheit
1	<b>Calibration:</b> 1 = Nominal 2 = Matched to sensor ±0.75% span For other calibration options, contact Minco
Y	<b>Sensor Leads:</b> Y = 2-lead RTD (or thermocouple) Z = 3-lead RTD X = 4-lead RTD
TT520PD(-25/200)C1Y = Sample part number	

### Dimensions in inches (mm)

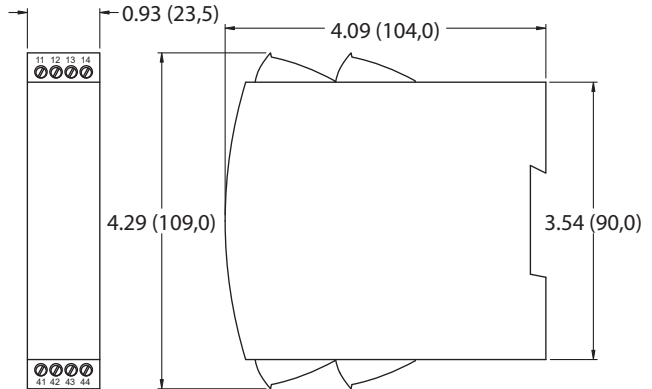

### Dimensions in inches (mm)

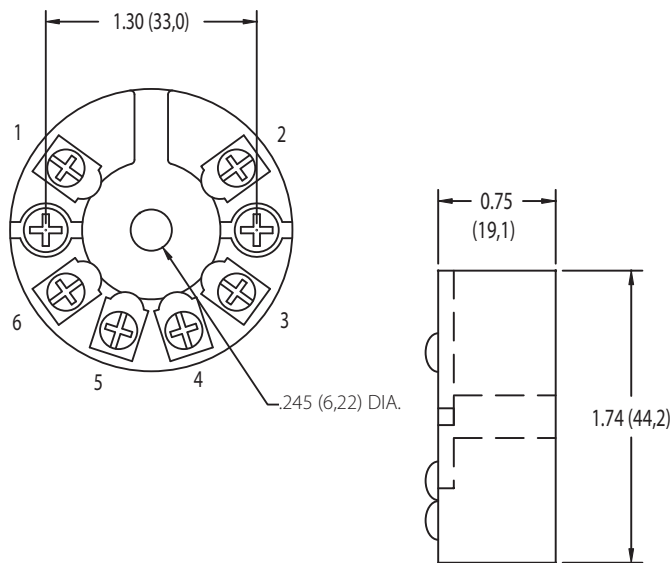

### Wiring Diagrams

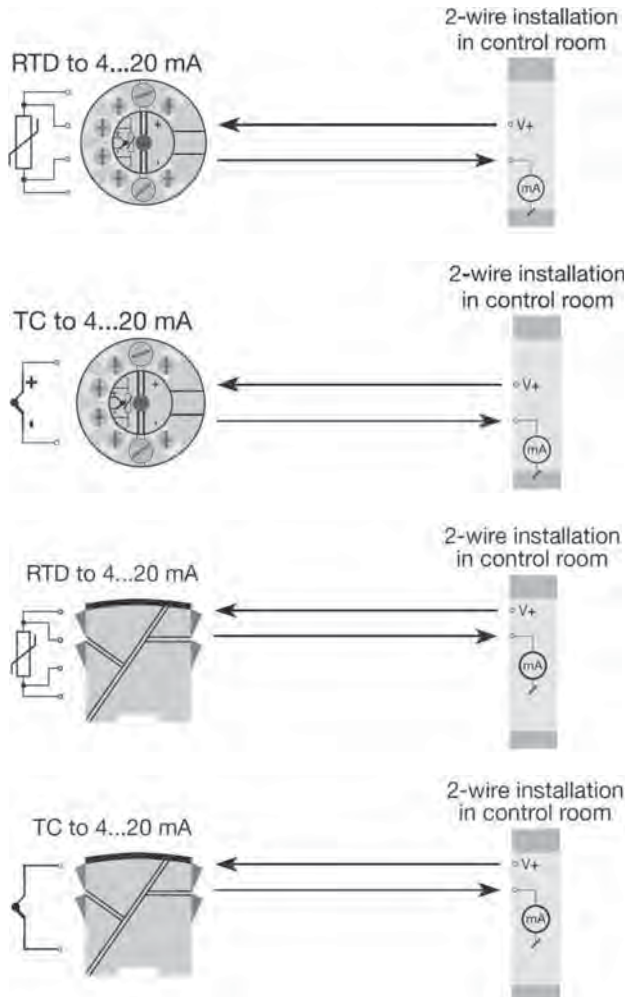

Specifications subject to change

# Programmable Transmitters w/ HART® Protocol



TT511/TT521

TT531

## Overview

Models TT511, TT521 and TT531 are programmable transmitters designed for process control and other applications. All three models use HART® communication protocol and are PC programmable to accept a signal from a thermocouple, a Resistance Temperature Detector (RTD), or a millivolt signal. Model TT511/TT521 transmitter can be mounted at the field location in a standard DIN form B head or on a DIN rail inside a local box (with an AC807 Minco DIN rail adapter). Model TT531 can be mounted vertically or horizontally on a DIN rail.

- T/C, RTD, or mV input
- HART® 7/5 Communication Protocol
- PC and field-programmable
- Galvanically isolated
- FM Approved Intrinsically Safe
- Single temperature measurement
- Difference temperature measurement
- Average temperature measurement

## HART® Communication

By way of 2-wire HART® communication between the process computer and the TT511, TT521 or TT531, the transmitter is programmable, readable, and controllable.

- Up to 63 transmitters can be controlled in a multidrop system. (Parallel connection of all transmitters on 2 wires).
- Set-up, configuration and control can be done from a central monitoring room.

When each transmitter is connected to a 2-wire cable, a standard 4-20 mA signal can be used at the same time as the HART® communication.

## Specifications

### Common Specifications:

**Supply voltage:** 8.0 - 30 VDC

*Specifications subject to change*

**Communication interface:** HART® 7/5 and PC interface

**Temperature coefficient:**  $< \pm 0.005\%$  of span/ °C

**Effect of supply voltage change:**  $< 0.005\%$  of span/ VDC

**Max. wire size:** AWG14 (1.5 mm<sup>2</sup>)

**Air humidity:** 0 - 95% RH

### Dimensions:

TT511/TT521: Ø1.73 x 0.84 in (Ø44 x 20.2mm)

TT531: 4.29 x .0.93 x 4.09 in (109 x 23.5 x 104mm)

### Tightness (enclosure/terminal):

TT511/TT521: IP 68 / IP00    TT531: IP50 / IP20

### Weight:

TT511/TT521: 50 g

TT531: 145 g

### AC205817 USB Loop Link Programmer:

TT511/TT521 and TT531 transmitters are preconfigured for ease of use. The AC205817 USB Loop Link Programmer allows the user to reconfigure the transmitter using free, Windows-based software.

### TC Input:

#### Minimum measurement range:

Type E, J, K, T : 50°C

Max. offset: 50% of selected max. value

#### Basic accuracy:

Type E, J, K, T :  $\pm 0.5^\circ\text{C}$

Cold junction compensation (CJC):  $\leq \pm 1.0^\circ\text{C}$

#### Temperature coefficient:

Type E, J, K, T :  $\pm 0.025^\circ\text{C} / ^\circ\text{C}_{\text{amb}}$

Sensor error detection: yes

### RTD-input:

RTD type	Minimum value	Maximum value	Minimum span.
PD (Pt100)	-200°C	+850°C	25°C
PF (Pt1000)	-200°C	+850°C	25°C

Basic accuracy PD/PF (Pt100/1000):  $\leq \pm 0.1^\circ\text{C}$

Temperature coefficient:  $\leq \pm 0.005^\circ\text{C} / ^\circ\text{C}$

### Current output:

Signal range: 4 - 20 mA

Load resistance:  $< (V_{\text{sup.}} - 8) / 0.023 [\Omega]$

**Intrinsic Safety data:** FM Approved Intrinsically Safe for Class 1, Div. 1, Groups A-D, Entity Approval (pending)

$V_{\text{max}}$ : 30.0 VDC                       $C_i$ : 1 nF

$I_{\text{max}}$ : 120 mA DC                       $L_i$ : 10  $\mu\text{H}$

$P_{\text{max}}$ : 0.84 W

Europe: ATEX II 1 G

### Meets these European requirements:

EMC 2004/108/EC: Standard EN 61326-1



## Specifications and order options

TT521	<b>Model Number:</b> TT511 No Approvals, Temperature Transmitter with HART® protocol, fits .250" Probe Max TT521 Temperature Transmitter with HART® Protocol, fits .236" Probe Max TT531 DIN Rail Temperature Transmitter with HART® Protocol
PD	<b>Sensor Type:</b> PD = 100Ω Platinum RTD (0.00385) PF = 1000Ω Platinum RTD (0.00385) E = Type E Thermocouple J = Type J Thermocouple K = Type K Thermocouple T = Type T Thermocouple
(-25/200)	<b>Temperature Range:</b> Specify temperature range in either °C or °F. For example, -25° to +200°C = 4 to 20 mA.
C	<b>Temperature Units:</b> C = Celsius F = Fahrenheit
1	<b>Calibration:</b> 1 = Nominal 2 = Matched to sensor ±0.75% span For other calibration options, contact Minco
Y	<b>Sensor Leads:</b> Y = 2-lead RTD (or thermocouple) Z = 3-lead RTD X = 4-lead RTD
TT521PD(-25/200)C1Y = Sample part number	

## Dimensions in inches (mm)

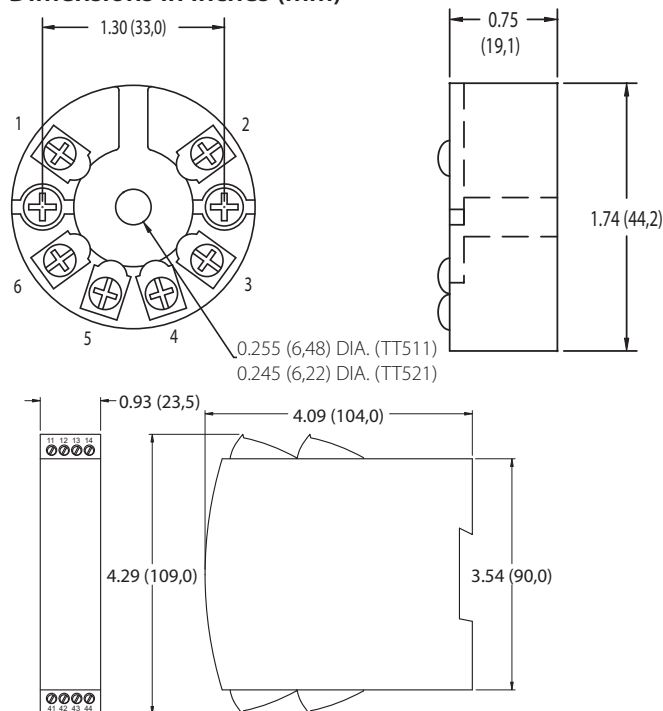

## Wiring Diagrams

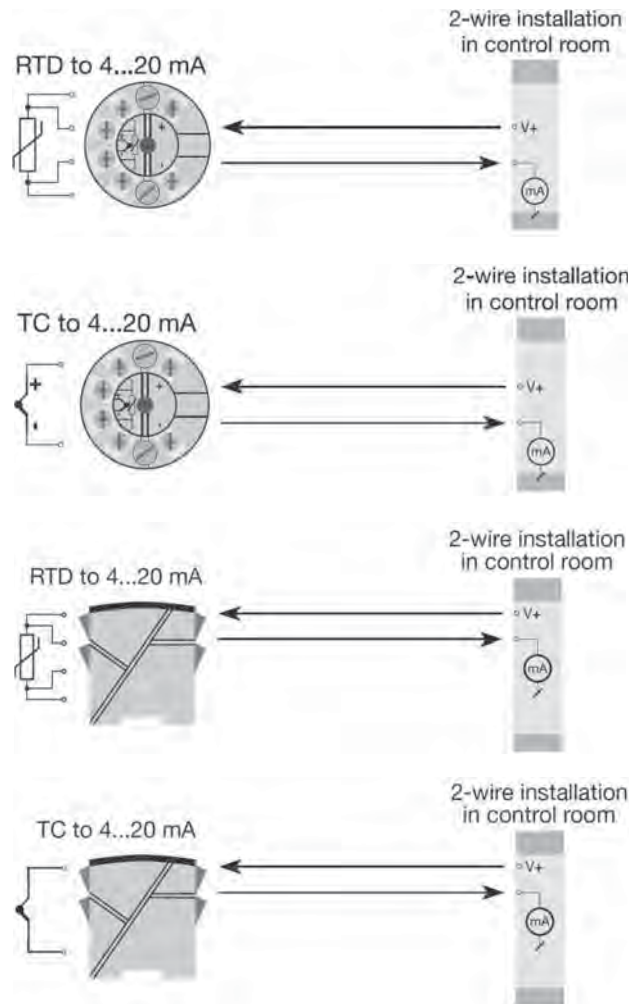

## HART® Multidrop Wiring Diagram

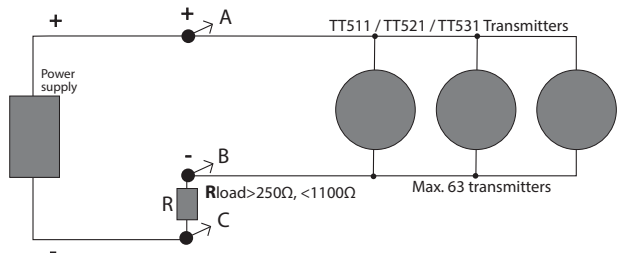

▼ = **STANDARD OPTIONS**  
 Specifications subject to change

# Temptran™ Temperature Ranges

Below is a list of commonly selected Temptran temperature ranges. The endpoints of the temperature range correspond to the Temptran's 4 and 20 mA signals. Choose the smallest possible span for best accuracy. Be sure to check the temperature limits of the sensor you specify.

If you do not find the temperature range required by your application, go to [www.minco.com](http://www.minco.com) for a complete list of temperature ranges. Custom ranges are also available for a small setup charge. Contact Minco Sales and Customer Service for more information.

For more temperature ranges (over 400 options) go to [www.minco.com](http://www.minco.com)

Range code	Temperature Range				RTD Temptrons			Thermocouple Temptrons	
	Zero °F	Span °F	Zero °C	Span °C	TT111, TT115, TT211, TT829		TT246, TT220	TT221	TT205
					Platinum elements*	Other elements	Elements	T/C types	T/C types
MH	-328	-148	-200.0	-100.0	PA PB PD PE				
HG	-325	100	-198.3	37.8	PA PB PD PE PF PW			JT	
QS	-300	150	-184.4	65.6			PA PB PD PE		
EZ	-148	32	-100.0	0.0	PA PB PD PE PF PW		PA PB PD PE		
LN	-148	212	-100.0	100.0	PA PB PD PE				
SA	-140	100	-95.6	37.8			PA PB PD PE		
UL	-103	752	-75.0	400.0				K	
M	-58	122	-50.0	50.0	PA PB PD PE PF PW		PA PB PD PE		
EO	-58	212	-50.0	100.0	PA PB PD PE	NA	PA PB PD PE	T	ET
JD	-58	302	-50.0	150.0	PA PB PD PE		PA PB PD PE	J	
MR	-58	500	-50.0	260.0			PA PB PD PE CA NA		
SD	-50	100	-45.6	37.8	PA PB PD PE				
MI	-50	150	-45.6	65.6	PA PB PD PE		PA PB PD PE	T	
AI	-50	275	-45.6	135.0	PA PB PD PE PF PW	FB FC FL NA	PA PB PD PE		
MS	-50	650	-45.6	343.3	PA PB PD PE		PA PB PD PE		
AD	-40	120	-40.0	48.9	PA PB PD PE	FB FC	PA PB PD PE		
AK	-40	140	-40.0	60.0	PA PB PD PE PU		PA PB PD PE		
BE	-40	160	-40.0	71.1	PA PB PD PE	FB	PA PB PD PE		
GH	-40	212	-40.0	100.0	PA PB PD PE		PA PB PD PE		
UE	-40	302	-40.0	150.0	PA PB PD PE		PA PB PD PE		
L	-30	120	-34.4	48.9	PA PB PD PE PF PW	FB FC			
AS	-30	130	-34.4	54.4	PA PB PD PE PF PW	FB	PA PB PD PE		
R	-30	150	-34.4	65.6	PA PB PD PE	FB FC	PA PB PD PE		
DN	-22	122	-30.0	50.0	PA PB PD PE		PA PB PD PE		
EE	-22	302	-30.0	150.0	PA PB PD PE		PA PB PD PE		
DO	-20	120	-28.9	48.9	PA PB PD PE PF PW	ND	PA PB PD PE		
EN	-20	140	-28.9	60.0	PA PB PD PE PF PW	FB	PA PB PD PE		
B	-20	180	-28.9	82.2	PA PB PD PE	FB FC NA	PA PB PD PE CA		
BP	-4	104	-20.0	40.0	PA PB PD PE	FC	PA PB PD PE		
SH	-4	122	-20.0	50.0	PA PB PD PE				
DB	-4	212	-20.0	100.0	PA PB PD PE		PA PB PD PE		
JZ	0	65	-17.8	18.3	PA PB PD PE		PA PB PD PE		
S	0	100	-17.8	37.8	PA PB PD PE PF PG PW	FB	PA PB PD PE PW		
JH	0	120	-17.8	48.9	PA PB PD PE PF PW	FC	PA PB PD PE		
HD	0	130	-17.8	54.4	PA PB PD PE PF PW		PA PB PD PE		
DV	0	150	-17.8	65.6	PA PB PD PE	FB	PA PB PD PE		
EI	0	160	-17.8	71.1	PA PB PD PE				
AC	0	200	-17.8	93.3	PA PB PD PE PF PW	FB NA	PA PB PD PE CA	EJKT	T
EY	0	250	-17.8	121.1	PA PB PD PE PF PW	NA	PA PB PD PE	JK	JKT
AN	0	300	-17.8	148.9	PA PB PD PE PF PW	FB FC NA	PA PB PD PE CA NA	EJKT	K
JA	0	350	-17.8	176.7	PA PB PD PE		PA PB PD PE	KJ	
DS	0	400	-17.8	204.4	PA PB PD PE	NA	PA PB PD PE CA NA	JK	
AG	0	500	-17.8	260.0	PA PB PD PE PF PW	NA	PA PB PD PE CA	EJT	JKT
QN	0	550	-17.8	287.8	PA PB PD PE		PA PB PD PE		
AB	0	600	-17.8	315.6	PA PB PD PE PF PW	NA	PA PB PD PE	EJK	J
AA	0	800	-17.8	426.7	PA PB PD PE PF PW		PA PB PD PE	J	JK
BZ	0	1000	-17.8	537.8	PA PB PD PE		PA PB PD PE	JK	EJ

\* Element codes (PA, PB, PD, PE, etc.) are defined in the Resistance/Temperature Tables on page 11-11

Specifications subject to change



For more temperature ranges (over 400 options) go to [www.minco.com](http://www.minco.com)

Range code	Temperature Range				RTD Temptrans				Thermocouple Temptrans	
	Zero °F	Span °F	Zero °C	Span °C	TT111, TT115, TT211, TT829		TT246, TT220		TT221	TT205
					Platinum elements*	Other elements	Elements	T/C types	T/C types	
HU	0	1300	-17.8	704.4				K		
BY	14	104	-10.0	40.0	PA PB PD PE		PA PB PD PE			
AJ	14	122	-10.0	50.0	PA PB PD PE		PA PB PD PE			
AP	20	70	-6.7	21.1	PA PB PD PE PF PW		PA PB PD PE			
GV	20	100	-6.7	37.8	PA PB PD PE PF PW		PA PB PD PE			
A	20	120	-6.7	48.9	PA PB PD PE PF PW	FA FB FC NA	PA PB PD PE PF			
HE	20	240	-6.7	115.6	PA PB PD PE					
AF	20	320	-6.7	160.0	PA PB PD PE	FA FB				
QE	22	122	-5.6	50.0	PA PB PD PE					
GW	23	131	-5.0	55.0	PA PB PD PE					
U	30	80	-1.1	26.7	PA PB PD PE PF PW	FB FC	PA PB PD PE			
DA	30	90	-1.1	32.2	PA PB PD PE PF PW	FC	PA PB PD PE			
DP	30	100	-1.1	37.8	PA PB PD PE PF PW					
BI	30	130	-1.1	54.4	PA PB PD PE PF PW		PA PB PD PE PF PW			
DQ	30	150	-1.1	65.6	PA PB PD PE	FB	PA PB PD PE			
KK	30	180	-1.1	82.2	PA PB PD PE					
EV	30	230	-1.1	110.0	PA PB PD PE		PA PB PD PE			
BN	30	240	-1.1	115.6	PA PB PD PE PF PW	FB	PA PB PD PE			
BJ	30	250	-1.1	121.1	PA PB PD PE PF PW	NA	PA PB PD PE FA			
GQ	32	100	0.0	37.8	PA PB PD PE PF PW		PA PB PD PE			
EG	32	104	0.0	40.0	PA PB PD PE PF PW		PA PB PD PE			
N	32	122	0.0	50.0	PA PB PD PE PF PW	FB FC	PA PB PD PE			
HL	32	167	0.0	75.0	PA PB PD PE		PA PB PD PE			
C	32	212	0.0	100.0	PA PB PD PE PF PW	FB FC NA	PA PB PD PE CA NA	JT		
QR	32	257	0.0	125.0	PA PB PD PE					
DL	32	280	0.0	137.8	PA PB PD PE		PA PB PD PE			
J	32	302	0.0	150.0	PA PB PD PE PF PU PW	FC NA	PA PB PD PE CA	J	J	
K	32	392	0.0	200.0	PA PB PD PE PU	NA	PA PB PD PE CA	JK	J	
LX	32	400	0.0	204.4	PA PB PD PE					
BW	32	482	0.0	250.0	PA PB PD PE	NA	PA PB PD PE	EJKT	J	
LF	32	572	0.0	300.0	PA PB PD PE		PA PB PD PE	JT		
JW	32	932	0.0	500.0	PA PB PD PE		PA PB PD PE	JK	K	
HA	32	1112	0.0	600.0	PA PB PD PE PF PW			K		
GF	32	1472	0.0	800.0	PA PB PD PE		PA PB PD PE	K	K	
SG	33.8	123.8	1.0	51.0	PA PB PD PE					
H	40	90	4.4	32.2	PA PB PD PE PF PW	FB	PA PB PD PE			
BU	40	100	4.4	37.8	PA PB PD PE PF PW					
QL	40	120	4.4	48.9	PF PW	FC				
BK	40	140	4.4	60.0	PA PB PD PE PF PW	FB	PA PB PD PE			
KH	40	240	4.4	115.6	PA PB PD PE PF PW		PA PB PD PE			
KP	42	92	5.6	33.3	PA PB PD PE					
DU	45	95	7.2	35.0	PA PB PD PE		PA PB PD PE			
DX	50	100	10.0	37.8	PA PB PD PE PF PW		PA PB PD PE			
AH	50	110	10.0	43.3	PA PB PD PE	FB	PA PB PD PE			
ED	50	120	10.0	48.9	PA PB PD PE PF PW	FB				
V	50	150	10.0	65.6	PA PB PD PE PF PW	FA FB NA	PA PB PD PE			
AV	50	230	10.0	110.0	PA PB PD PE PF PW		PA PB PD PE	J		
BF	50	250	10.0	121.1	PA PB PD PE PF PW		PA PB PD PE PF PW	ET		
AO	50	300	10.0	148.9	PA PB PD PE		PA PB PD PE CA FA			
KF	50	400	10.0	204.4	PA PB PD PE		PA PB PD PE			
D	70	220	21.1	104.4	PA PB PD PE PF PW	FB FC	PA PB PD PE			
E	100	500	37.8	260.0	PA PB PD PE PF PW		PA PB PD PE			
BH	122	302	50.0	150.0	PA PB PD PE		PA PB PD PE	T		
BL	200	500	93.3	260.0	PA PB PD PE PF PW			K		

\* Element codes (PA, PB, PD, PE, etc.) are defined in the Resistance/Temperature Tables on page 11-11

Specifications subject to change



# Temptran™ Calibration & Accessories

## Special high-accuracy calibration

Standard transmitters can be calibrated to the nominal resistance values of the RTD at the zero and span points. Total system error includes the tolerance of both the transmitter and the RTD sensor. If you order Minco Temptrons calibrated to the actual resistance of the RTD (traceable to NIST), this effectively eliminates the sensor tolerance from the system accuracy specifications.

Temptrons match calibrated to a sensor are always ordered as assemblies. Common examples are shown in Section 1.

## Free NIST traceability

With each matched sensor/transmitter set, Minco sends you calibration data traceable to the National Institute of Standards & Technology. This helps your process comply with ISO 9001 and other quality standards.

## Recalibration

Minco prints RTD resistance values right on the Temptran label to simplify recalibration. You simply connect a resistance decade box or "RTD simulator" in place of the RTD, dial in the correct values, and adjust zero and span.

Because Minco platinum RTDs are extremely stable in typical installations (0.1°C or better), you can trust the printed values for many years.

MINCO MPS, MIN, USA	MODEL	TEMPTRAN™	
	D/C: 9614		
	100 OHM PLATINUM RTD		
	4mA= 20.0°F= -6.7°C=	97.932Ω	
	20mA= 120.0°F= 48.9°C=	118.969Ω	

RTD resistances are printed on Temptran labels for easy recalibration of zero and span. A standard Temptran shows nominal values.

MINCO MPS, MIN, USA	MODEL	TEMPTRAN™	
	D/C: 9614 S/N: 103		
	100 OHM PLATINUM RTD		
	4mA= 20.0°F= -6.7°C=	97.427Ω	
	20mA= 120.0°F= 48.9°C=	118.988Ω	

A specially calibrated Temptran shows actual resistance of the serialized, connected RTD.

## Temptran Accessories

### DIN rail mounting

For easy installation in instrument cabinets. Adapters fit all Temptran models. Specify length when ordering rails.

Model	Description
AC805	DIN EN50022 Rail
AC807	Adapter for EN50022



Temptrons mounted to DIN rail

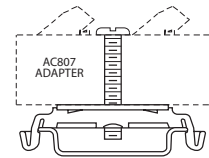

AC807 adapter for EN50022

### Dual mounting kits

The AC103528 mounting kit fits connection head models CH105, CH107, CH328, CH330, CH342, CH343, CH357, CH358, CH405 and CH407. It holds two miniature Temptrons in a single head for use with dual RTDs.

Use AC103133 for connection head models CH104, CH106 and CH306, and CH356. CH106, CH306 and CH356 also require AC103625 connection head modification.



AC103528  
mounting kit

AC103133  
mounting kit

▼ = STANDARD OPTIONS  
Specifications subject to change

# Loop-powered Indicators



TI196 Head-mounted Indicator



AC102765 Pipe Mounting Hardware Kit



TI350 Indicator

## Overview

The display range is field programmable via coarse dip switches and two fine adjustment potentiometers. Wiring is easy. Simply connect the indicator in series with the 4 to 20 mA loop. Forward voltage drop is only 2.8 VDC.

- Local indication of process variable for convenient visual verification
- Enclosures are sealed from harsh environments to enhance product reliability and longevity
- Variety of mounting options allows for flexible and easy installation
- Compatible with 4 to 20 mA temperature transmitters for easy sensor interchangeability
- IP66 NEMA 4X/7 rated (only for TI196)

## TI196 head-mounted indicator

The TI196 includes an explosionproof connection head and digital indicator for local indication of temperature. Sensors and transmitters are specified separately. Optional Temptran models TT111, TT211 or TT205 will fit inside the connection head along with the meter.

### TI196 Hazardous Area Certification (explosionproof/flameproof):

- Class I, Div I, Groups B,C and D
- Class II, Div I, Groups E,F and G
- Class III
- Ex d IIC

## TI350 indicator

The TI350 features a washdown compatible digital readout for local indication of temperature. Sensors and transmitters are specified separately. Optional Temptran model TT321 will fit inside the case along with the meter. Other 4 to 20 mA transmitters may be mounted outside the case and used with this device.

- NEMA 4X enclosure
- Cable glands are installed for 0.118" to 0.256" (3mm to 6.5mm) cable

## AC102765 pipe mounting hardware kit

Use AC102765 for mounting TI196 or TI350 to vertical or horizontal pipe. Kit includes plate, stainless U-bolts, nuts and washers for 2" schedule 40 pipe [Ø 2.375" (60mm)].

Order model number AC102765

▼ = STANDARD OPTIONS

Specifications subject to change

## TI196 head-mounted indicator

### Specifications

**Input:** 4 to 20 mA DC series connection

**Range:** User adjustable.  
Zero: -500 to +1000 counts.  
Span: 10 to 2000 counts.

**Accuracy:** ± (0.1% reading + 1 count).

**Temperature Coefficient:**  
Zero: ± 0.075 counts/°C typ.  
Span: ± 0.005% of span/°C typ.

**Linearity:** ± (0.1% of span + 1 count).

**Forward Voltage Drop:** 2.8 volts DC maximum.

**Display:** 0.59" (15mm) high, 3-1/2 digit LCD, with °C/°F descriptor.

**Display Update:** 3 times per second.

**Underrange Indication:** -1 in MSD (Most Significant Digit).

**Overrange Indication:** 1 in MSD.

**Connections:** Terminal Block, Pluggable

**Decimal:** User programmable to 1 position or absent (i.e. 1XX.X or 1XXX).

**Ambient Temperature Range:**  
Operating: 32 to 122°F (0 to 50°C).  
Storage: -4 to 149°F (-20 to 65°C).

**Weight:** 50 oz. (1420 g).

**Enclosure:** Aluminum, polyester-coated

**Enclosure Rating:** NEMA 4X, IP66

**Dimensions (connection head):** 4.5" W x 4.5" H x 3.4" D (144 mm W x 114 mm H x 87 mm D).

### TI196 specification and order options

TI196	Model number TI196
P3	Pipe thread size: P2 = 3/4 - 14 NPT (sensor and conduit) P3 = 1/2 - 14 NPT (sensor and conduit)
(0/100)	Temperature range: (4 mA temp./20 mA temp.), user adjustable
C	Display: C = Celsius F = Fahrenheit
TI196P3(0/100)C = Sample part number	

*Note: Sensors and transmitters are specified separately.*

## TI350 indicator

### Specifications

**Input:** 4 to 20 mA DC series connection

**Range:** User adjustable.  
Zero: -500 to +1000 counts.  
Span: 10 to 2000 counts.

**Accuracy:** ± (0.1% reading + 1 count).

**Temperature Coefficient:**  
Zero: ± 0.075 counts/°C typ.  
Span: ± 0.005% of span/°C typ.

**Linearity:** ± (0.1% of span + 1 count).

**Forward Voltage Drop:** 2.8 volts DC maximum.

**Display:** 0.59" (15mm) high, 3-1/2 digit LCD, with °C/°F descriptor.

**Display Update:** 3 times per second.

**Underrange Indication:** -1 in MSD (Most Significant Digit).

**Overrange Indication:** 1 in MSD.

**Connections:** Terminal Block, Pluggable

**Decimal:** User programmable to 1 position or absent (i.e. 1XX.X or 1XXX).

**Ambient Temperature Range:**  
Operating: 32 to 122°F (0 to 50°C).  
Storage: -4 to 149°F (-20 to 65°C).

**Weight:** 7 oz. (200 g).

**Enclosure:** Polycarbonate, NEMA 4X.

**Dimensions (box only):** 2.6" W x 4.5" L x 2.2" D (65 mm W x 115 mm H x 56 mm D).

### TI350 specification and order options

TI350	Model number TI350
(0/100)	Temperature range: (4 mA temp./20 mA temp.), user adjustable
C	Display: C = Celsius F = Fahrenheit
TI350(0/100)C = Sample part number	

*Note: Sensors and transmitters are specified separately.*

▼ = **STANDARD OPTIONS**  
Specifications subject to change

# CT224 12-Channel Temperature Alarm/Monitor



INSTRUMENTS

## Overview

The CT224 consists of a 12-Channel temperature monitor/over-temperature alarm and MincoSoft™ CT224 Software. It is the next generation in temperature monitoring equipment from Minco designed to meet the needs of electric machinery protection. The 12-channel scanning capability, standard RS485/RS232 interface and Windows-compatible software utility for system configuration and data logging provide over-temperature and under-temperature protection and critical feedback to safeguard expensive machinery.

- UL and cUL recognized to help meet regulatory compliance
- PC programmable with Windows compatible software makes monitoring easy and efficient, allowing quick reprogramming and extensive data logging
- Mix and match sensor input types for freedom to adapt to pre-installed bearing and apparatus sensors
- Ability to monitor 12 inputs allows you to monitor stator sensors from two motors
- Five outputs, relays or logic offers either internal relay trips or flexibility of external control
- Logic outputs can be used with external SSRs
- Prevent costly damage to motors, generators, transformers, and other equipment
- Power loss protection
- 24 independent trip points (2 per channel)
- Programmable deadband (hysteresis)
- Rugged steel enclosure
- Can be used as a 4-channel on/off controller
- Display High, Low, or Any valid zones
- Self-calibrating

## Software

MincoSoft™ CT224 software features:

- Compatibility with Microsoft® Windows® operating system
- User-friendly configuration program
- Save unlimited set-up configurations
- Commission mode to test configurations before implementation
- Continuously displayed measurement and relay status of all 12 channels
- Data-logging

## Applications

- Generators
- Motors
- Turbines
- Compressors
- Pumps

▼ = **STANDARD OPTIONS**  
Specifications subject to change



## Specifications

**Input:** 1 to 12 RTDs (2 or 3-wire), thermocouples, or 4 to 20 mA current loops. Accepts any combination of input types.

### Standard Input types:

RTD:

- 200 to 700°C: PA (Platinum / 100 Ω / 0.00392 Ω/Ω/°C)
- 200 to 700°C: PB (Platinum / 100 Ω / 0.00391 Ω/Ω/°C)
- 200 to 850°C: PD/PE (Platinum / 100 Ω / 0.00385 Ω/Ω/°C)
- 200 to 600°C: PF (Platinum / 1000 Ω / 0.00385 Ω/Ω/°C)
- 80 to 260°C: NA (Nickel / 120 Ω / 0.00672 Ω/Ω/°C)
- 100 to 260°C: CA (Copper / 10 Ω / 0.00427 Ω/Ω/°C)

Thermocouple:

- 270 to 1000°C: Type E    -270 to 1150°C: Type K
- 200 to 1200°C: Type J    -270 to 400°C: Type T

**4 to 20 mA current loop:** Pressure (PSI, Bar), Humidity (%), Temperature (°F, °C), Vibration (G), and process variable (mA, VDC)  
Note: 4 to 20 mA inputs must be linear with respect to the measured variable.

**Input scan rate:** 1.5 seconds maximum to scan all 12 channels.

**Input fault detection:** Options for ignoring, sounding alarm, or tripping relays associated with the failed sensor. Other zones are unaffected.

**Output:** 24 independent trip points (2 per channel): 5 relays, one relay is intended for use as an alarm function (but can be configured as a trip point), and one internal audible alarm. Alarm may be programmed to sound when selected relays trip. Logic output option is available for controlling external SSRs or sending a signal to another device.

**Relays:** Form C, SPDT 10 A @ 250 VAC/24 VDC resistive load; 10 A make current; 2500 VA breaking capacity, ¼ HP at 120 VAC motor load.

**Trip point hysteresis (deadband):** Programmable from 0 to 20 (°C or °F).

**Display:** 20 x 4 line backlit LCD. 0.1°C or 0.1°F resolution. Front panel LEDs indicate relay and alarm status.

**Accuracy:** 2°C (3°F) in 0 to 60°C (32 to 140°F) ambient, over entire range of the input.

**Supply power:** 85 to 240 VAC @ 50/60 Hz. or 110 to 250 VDC, 5 watts max.; or 18 to 36 VDC, 6 watts max.

**Keyboard:** 4 membrane type keys with audible feedback.

**Serial interface:** RS485 or RS232 (Modbus protocol).

**Power loss protection:** Trip points and program parameters stored in non-volatile memory. Normal operation resumes when power is restored.

**Programming:** Programmable from front panel or via RS485 or RS232 interface using Modbus protocol. PC software is included for data logging, commissioning, and configuration. Program settings may be password protected.

**Firmware fault protection:** Watchdog resets microprocessor if it fails to perform program sequence.

**Enclosure:** Steel case; NEMA 4 front panel.

**Ambient temperature rating:** 0 to 60°C (32 to 140°F).

**Connections:** Terminal blocks at rear accept wires to AWG 12.

**Leadwire resistance compensation:** Up to 30 Ω per leadwire for RTDs with no effect on reading.

**Dimensions:** 7.5 x 11.5 x 2" (191 x 292 x 51 mm).

**Mounting:** Panel mount enclosure. Cutout size of 6.8" x 10.6" (173 x 269 mm).

**Weight:** 3.8 lbs. (1.72 kg.).

**Approvals:** UL 508, CSA C22.2 No. 14-M91.

## Accessories

**AC102734:** Communication package. Includes isolated RS232 to RS485 converter and power supply.

## Specification and order options

CT224	Model number
A	Power supply A: 85-240 VAC @ 50/60 Hz / 110-250 VDC B: 18-36 VDC
1	Output 1: Relays 2: Logic (5 VDC)
A	Interface A: RS232 B: RS485
CT224A1A = Sample part number	



**STOCKED PARTS AVAILABLE**

▼ = **STANDARD OPTIONS**  
Specifications subject to change



# CT424 Temperature Alarm/Monitor

**User-programmable three input temperature monitor system**

## Overview

Minco's CT424 consists of a 3-channel temperature monitor and alarm system that controls three relay outputs based on user-programmable set points to help safeguard expensive machinery.

## Features

The CT424 offers users a completely programmable monitor and alarm with improved measurement range and universal inputs. The microprocessor-based design maintains accuracy over a wide range of temperatures and conducts regular self-checks to ensure correct operation. Additionally, one of the relay outputs is specifically designed for control of a cooling fan, and the user-configurable fan exercise option extends the fan life and reduces bearing lock-up. Other key features include:

- Universal inputs of 100 and 1000  $\Omega$  platinum RTDs and Types E and K thermocouples
- Configurable through the front-panel interface, MODBUS over USB or the isolated RS-485, PC software included for data logging and configuration
- User-configurable measurement range to Celsius or Fahrenheit scale
- Large, dimmable 7-digit LED display allows easy programming and visibility at various distances and lighting conditions
- Dual password design allows certain users to have full configuration access and others, set points only
- Non-volatile memory storage of per-channel min/max temperatures for recall in the event of power-loss
- Electrically isolated 4-20mA output signal allows for connection to PLCs or remote displays
- UL/cUL recognition (CT424A and CT424B) and CE certification (CT424A)



INSTRUMENTS

## Applications

Minco's CT424 temperature monitor and alarm is designed with the specifications for dry-type transformer monitoring and protection. Additional applications include use in pumps, compressors and motors.

## Specification and order options

CT424	Model number
CT424A	AC power, 120-240VAC 50-60Hz, 120-240VDC
CT424B	DC power: 21-36VDC

▼ = **STANDARD OPTIONS**  
Specifications subject to change



## Technical Specifications

Performance	Measurement Range	-50°C to 300°C (-58°F to 572°F), 1°C resolution, 2°C full-range accuracy
	Relay Contact Ratings	Voltage: 240V AC Fan Relay: 30A or 1.5HP @ 55°C, derates to 22A or 1.5HP @ 72°C Trip/Alarm Relays: 10A
	Current Loop Outputs <i>Isolated, industry-standard 4-20mA current-loop output for forwarding of reading to PLC or remote indicator.</i>	Configuration: high value, low value, specific channel selection. Scaling: Offset from -50°C to 250°C, span from 50°C to 350°C Error signaling: 3.5mA or 23mA output during sensor failure. Power: isolated loop power –or– non-isolated self-power
	Communications	MODBUS over USB or isolated RS-485, RTU, 300-38400bps
	Certifications	UL/cUL recognized (CT424A and CT424B) and CE certification (CT424A)
Environment	Sensor Inputs <i>Note: "Universal" inputs are standard and are electrically isolated from control logic and communications.</i>	RTD: 100Ω or 1000Ω Platinum, 0.00385Ω/Ω/°C TCR, 2- or 3-wire connection, Open and shorted sensor detection Thermocouple: Type K or Type E thermocouple, open detection.
	Temperature Range	-30°C to 72°C (-22°F to 162°F), 95% humidity, non-condensing
	Output Relays	Connection: terminal block, 30 AWG to 10 AWG wire
Mechanical	User Interface	Display: LED, 7-segment, red, 0.56" height, dimmable Indicators: LED, red: Fan, Trip, Alarm, Peak, Manual Fan, Test
	Dimensions	Front-panel: 6.3" x 9.9" Cut-out: 5.67" x 9.17" Depth: 1.9"
	Enclosure	Metal, corrosion-resistant

▼ = STANDARD OPTIONS  
Specifications subject to change

# CT325 Miniature DC Temperature Controller

## Overview

The CT325 Miniature DC Temperature Controller is designed for use with Minco Thermofoil™ heaters and RTD or thermistor sensors. It offers inexpensive on/off temperature control of your process or equipment with accuracy many times better than bimetal thermostats. Easily read and adjust the set point temperature using a voltmeter, then monitor the actual signal temperature at the other end. Operating from your 4.75 to 60 volt DC power supply, the controller can switch up to 4 amps power to the heater. A bright LED indicates when power is applied to the heater.

The entire unit is epoxy filled for moisture resistance, with a through-hole for a mounting bolt. A terminal block provides the power input, sensor input and heater output connections.

- Tight control in a small package means that enclosures or panel spaces are not required which allows successful portable device implementation
- Simple control without complicated programming can reduce set-up time
- Three-wire RTD connection cancels lead resistance for highly accurate temperature readings
- Solid state on-off control with adjustable set point improves durability compared to electro-mechanical devices
- Flexible heating control compliments all Minco Thermofoil™ Heaters for convenient off the shelf operation
- Uses standard 100 Ω or 1000 Ω platinum RTD or 50 kΩ thermistor sensor input
- Single DC power source provides power to the controller and heater up to 240 watts

## Applications

- IV solutions for medical/surgical applications
- Military batteries
- Enclosures to maintain the temperature of electronics
- Ruggedized laptop LCDs and hardrives

## Custom design options

Minco can customize the design of the CT325 for special applications. Specific temperature ranges, other sensor options, and special packaging are possible for volume OEM applications.

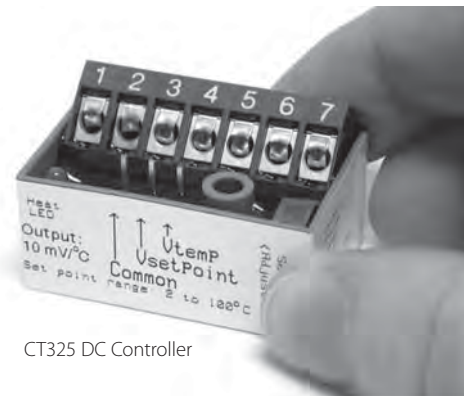

CT325 DC Controller

## Specifications

**Input:** 100 Ω or 1000 Ω platinum RTD, 0.00385 Ω/Ω/°C, 2 or 3-leads, or 50 k Ω NTC thermistor, 2-lead.

**Setpoint range:** 2 to 200°C (36 to 392°F) for platinum RTD input. 25 to 75°C (77 to 167°F) for thermistor input. Consult factory for other ranges.

**Setpoint stability:** ±0.02% of span/°C.

**V<sub>temp</sub> signal:** 0.010 V/°C over specified range.

Platinum RTD sensor		Thermistor sensor	
2°C	0.02 V	25°C	0.25 V
50°C	0.50 V	50°C	0.50 V
100°C	1.00 V	75°C	0.75 V
200°C	2.00 V		
Accuracy:	±1% of span	Accuracy:	±2% of span
Linearity:	±0.1% of span	Linearity:	±2% of span

**Deadband:** ±0.1°C (0.2°F).

**Input power:** 4.75 to 60 VDC.

**Output:** Open drain, 4 amps max. DC.

**Leadwire compensation:** (3-wire RTD) ±0.06°C/Ω for 100 Ω or 1000 Ω platinum up to 25 Ω per leg.

**Fault protection:** Heater disabled on RTD short or thermistor open. No heater protection; external fuse is recommended.

**Operating ambient temperature range:** -40 to 70°C (-40 to 158°F).

**Relative humidity:** 0 to 95% non-condensing.

**Physical:** Polycarbonate case, epoxy sealed for moisture resistance.

**Weight:** 1 oz. (28g).

**Connections:** Terminal block for wires AWG 22 to AWG 14.

**Mounting:** Mounting hole for #6 screw through or #8 thread forming screw.

▼ = **STANDARD OPTIONS**  
Specifications subject to change

Sensor type	Code
100Ω platinum RTD (0.00385 TCR)	PD
1000Ω platinum RTD (0.00385 TCR)	PF
50 kΩ thermistor R25/R125 = 31.2	TF

Note: 50kW thermistor sensor TS665TF is available on page 9-6

### Specification and order options

CT325	Model number
PD	Sensor type from table
1	Power supply: 1 = 4.75 to 10 VDC 2 = 7.5 to 60 VDC
C	Temperature range: A = 25 to 75°C (thermistor only) C = 2 to 200°C (RTD only)
1	Dead band: 1 = 0.1°C
CT325PD1C1 = Sample part number	

### Dimensions in inches (mm)

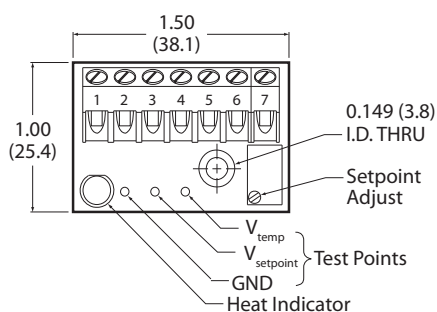
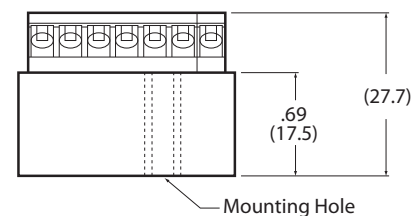

### Wiring diagrams

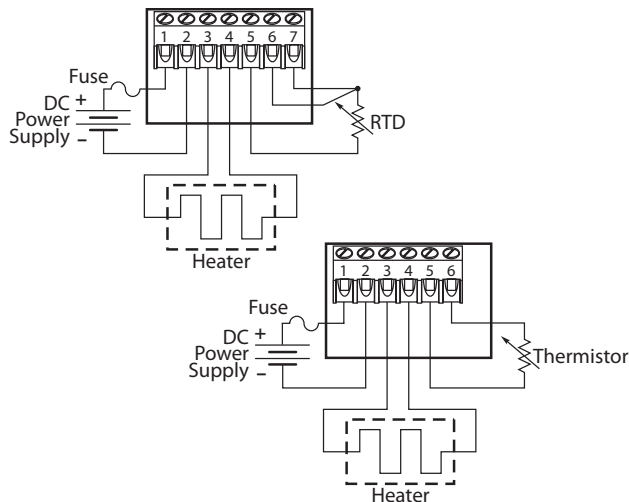

### AC powered heaters

The CT325 can provide the control signal to an external solid state relay to switch AC power. Use a DC supply voltage suitable for both the CT325 and SSR.

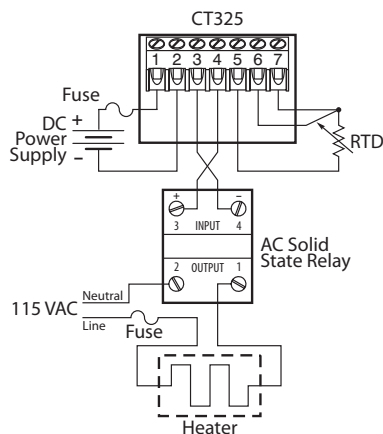

**STOCKED PARTS AVAILABLE**

▼ = **STANDARD OPTIONS**

Specifications subject to change

# CT335 PC Board Mount Temperature Controller

## Overview

The CT335 is an OEM micro-processor based temperature controller that offers two sensor inputs, and two outputs. This low cost, PCB mount style proportional controller is great for system integration.

The CT335 multiple output options make it more versatile than other temperature controllers. Option 1) one output capable of handling up to 6 Amps. Option 2) Two open drain outputs with 3 Amps each. Option 3) one open drain output that can handle up to 3 Amps and a logic output option to work with an external SSR for higher power.

- Proportional and On/Off control
- Two inputs and two outputs (solid state)
- Small package designed for PCB mounting
- Able to handle up to 6 Amps
- Operates on 7.5-60 volts DC
- Low cost

## Specifications

### Sensor Inputs:

100Ω at 0°C Pt RTD, 2-leads (0.00385 TCR)

1000 Ω at 0°C Pt RTD, 2-leads (0.00385 TCR)

### Output Options:

One output of 6A

Two outputs of 3A each

One 3A output and one logic output (0-5V)

### Controlling Parameters:

Dead-band for On/Off Control: 0.1 to 10°C

Proportional band for Proportional Control: 0.1 to 10°C

### Ambient:

Operating temperature: -40 to 70°C (-40 to 158°F)

Storage temperature: -55 to 85°C (-67 to 185°F)

Relative humidity: 90%, non-condensing

### Accuracy: ±1° C

System stability determined by overall system.

### Power supply: 7.5 to 60VDC

**Physical:** ABS case, epoxy potted for moisture resistance

**Case Dimensions:** 1.49x1.03x0.36"

**Mounting:** Pins on 0.1" center for mounting on PCB



### AC207473 USB to SPI Converter Kit:

The AC207473 allows the user to configure the CT335 from a PC. It is ideal for prototyping and early-stage development. It consists of a CT335 USB to SPI converter, power supply, USB cable, and software CD for easy user interface.

## Operation

The CT335 controller can be configured to On/Off or Proportional control. On/Off control offers faster reaction time and better accuracy over thermostats. The CT335 Proportional control minimizes temperature overshoot and gives steadier temperature control by reducing the time the heater/load stays on as the process temperature approaches the set-point. Note that actual outputs depend on the system's configuration and controlling parameters. See below.

### On/Off Control

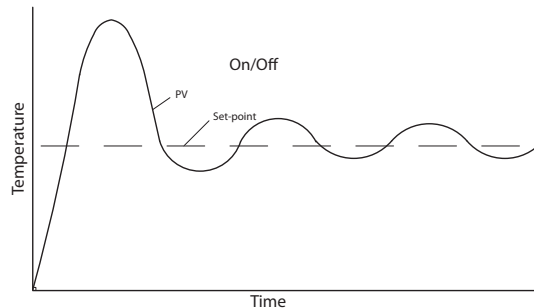

### Proportional Control

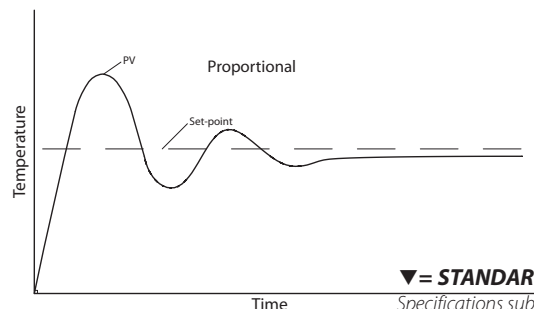

▼ = STANDARD OPTIONS  
Specifications subject to change

Specifications subject to change

## Wiring with Different Output Options:

### Option 1: One output of 6A

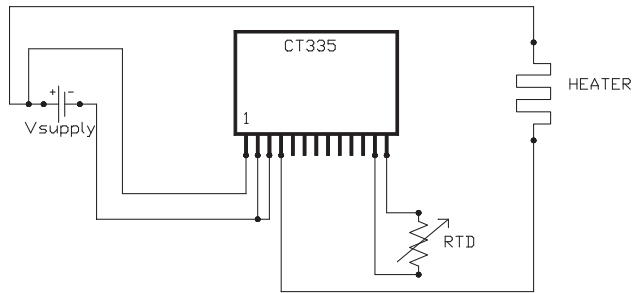

### Option 2: Two outputs of 3A each

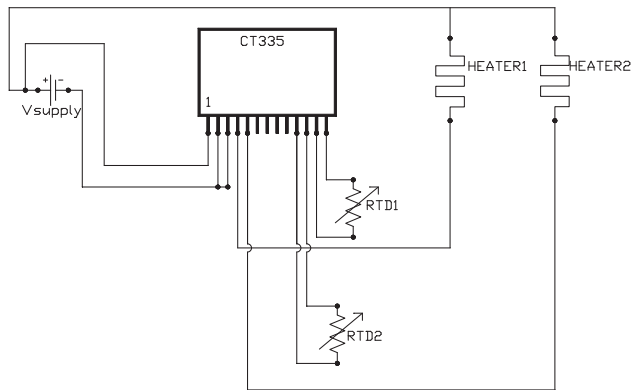

### Option 3: One 3A output and one logic output (0-5V)

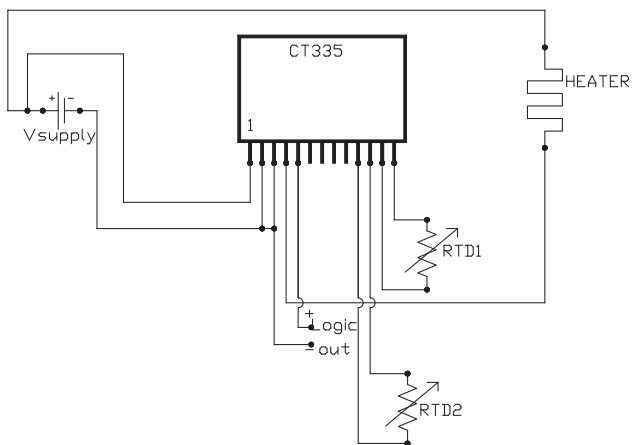

## Specifications and order options

CT335	Model Number: CT335
PD	Sensor Types: PD = 100Ω Platinum RTD (-40 to 200°C) PF = 1000Ω Platinum RTD
1	Output Options: 1. one output of 6A 2. two outputs of 3A 3. one 3A output and 1 logic output
P	Control Method: O = On/Off P = Proportional
10	Dead-band or Proportional Band 1 = 0.1° C 10 = 1.0° C 100 = 10.0° C
T100	Setpoint Temperature (Min = -40°C, Max = 200°C): XXXX = Setpoint in 0.1°C increments Example: 100 = 10.0°C 103 = 10.3°C -200 = -20.0°C
CT335PD1T100 = Sample part number	

## Dimensions

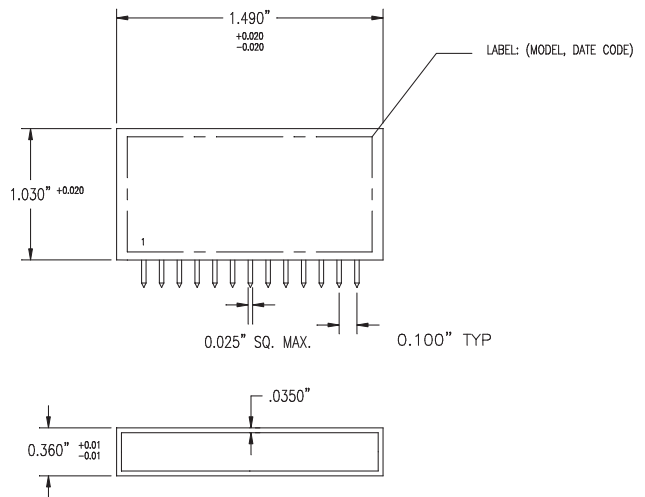

▼ = STANDARD OPTIONS  
Specifications subject to change

# CT435 PC Board Mount Temperature Controller

## Programmable Multi-input/output Controller

### Overview

The CT435 is an OEM micro-processor based PID temperature controller that offers two independent sensor inputs and two outputs. This low cost, PCB mount style PID controller is very flexible through its many configuration options. Using the UART Modbus interface, system parameters, sensor temperatures, and output status may be read and/or written, allowing for complete system integration with existing micro-processors.

- Two RTD temperature sensor inputs – Pt100 or Pt1000
- Wide temperature sensing range
- All controller features are configurable through the UART Modbus interface
- Two independent solid state open drain outputs – 3A each
- Each output individually configurable for any variation of PID, On/Off, or Alarm control
- Auto-tune feature estimates PID coefficients for several control types
- 32-bit microprocessor executes both PID loops simultaneously at individually configurable rates up to 25 times/second
- Addressable Modbus protocol allows for multiple units connected on one set of UART lines
- No additional heat sinking required
- Small package designed for PCB mounting
- Operates from a 5V supply
- Low cost

### Specifications

#### Sensor Inputs:

100  $\Omega$  at 0°C Pt RTD, 2-leads (0.00385 TCR)  
 1000  $\Omega$  at 0°C Pt RTD, 2-leads (0.00385 TCR)  
 2-wire connection  
 Open and shorted sensor detection

#### Measurement Range:

-70°C to 650°C (-94°C to 1202°F), 0.25°C full-range accuracy at 25°C ambient

#### Accuracy:

25°C ambient:  $\pm 0.25^\circ\text{C}$  or  $\pm 0.25\%$  of range  
 Full range ambient:  $\pm 1.5^\circ\text{C}$  or  $\pm 1\%$  of range  
 System stability determined by overall system.



### Electrical:

Input power: 5 to 24VDC, 20mA typical, 40mA max

Outputs: 2 open drain outputs, 60V max switching voltage

Number of Outputs in Use	Controller Supply Voltage	Ambient Temperature	Current Rating
1 Output	5-12 VDC	25°C	7 A
		70°C	4 A
	12-24 VDC	25°C	6 A
		70°C	3 A
2 Outputs	5-12 VDC	25°C	5 A
		70°C	3 A
	12-24 VDC	25°C	5 A
		70°C	2.5 A

### Environmental:

Operating temperature: -40 to 70°C (-40 to 158°F)

Storage temperature: -55 to 85°C (-67 to 185°F)

Relative humidity: 90%, non-condensing

### Communication:

Modbus over UART – 19.2kbps, no flow control

### Package:

Enclosure: ABS case, epoxy potted

Dimensions: 1.49x1.03x0.36"

Mounting: Pins on 0.1" center for mounting on PCB

▼ = **STANDARD OPTIONS**

Specifications subject to change

### Operation:

The CT435 controller can be configured to PID (and any variation) or On/Off control. On/Off control offers faster reaction time and better accuracy over thermostats. PID control minimizes temperature overshoot and gives steadier temperature control by utilizing proportional, integral, and derivative control factors. The inputs and outputs may be configured in any fashion, and all parameters are read/write through the addressable UART Modbus interface. The controller and heaters may be powered from the same supply or separate supplies, as long as they share a common ground.

### How to Order:

CT435	Model number
PD	Sensor Types: PD = 100 $\Omega$ Platinum RTD PF = 1000 $\Omega$ Platinum RTD
CT435PD = Sample part number	

### Common Wiring Diagram:

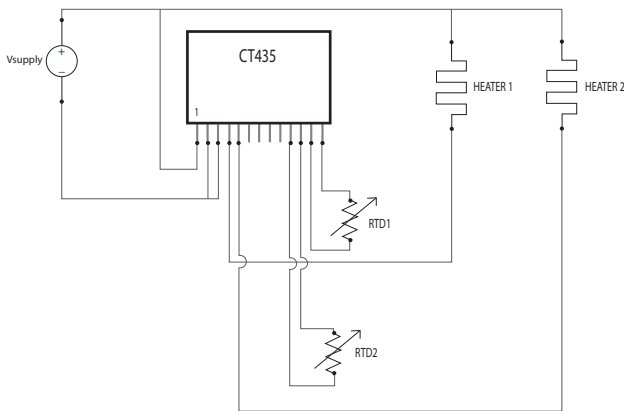

### Dimensions:

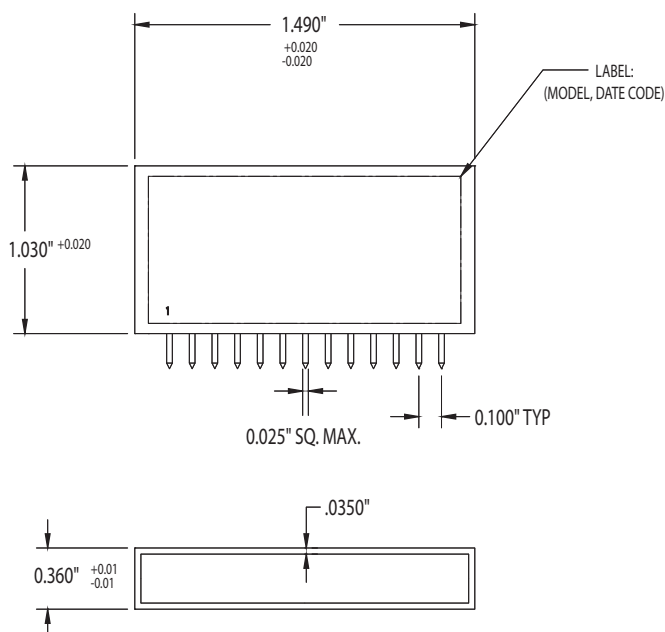

▼ = STANDARD OPTIONS  
Specifications subject to change



# CT15 Temperature Controller & Alarm



CT15 Controller

## Overview

The CT15 is an easy-to-use controller with sophisticated PID control. It can also be a single or 2-stage alarm (using alarm feature plus control relay) to monitor motors and generators for overheating.

- RTD or thermocouple input
- Control modes: Self-Tune, pre-set or programmable PID, or On/Off
- Bright red LED display
- Ramp to setpoint
- Digital sensor input correction
- Digital input filter adjustable for noisy or jittery processes
- Four security levels
- Setpoint limits
- Non-volatile memory needs no battery backup
- Input fault timer
- Alarms at one or two temperatures
- Alarm Relay option is programmable for high, low, absolute, or deviation, can be reset manually or automatically, and controls a single electromechanical relay with voltage-free contacts

## Specifications

### Selectable inputs:

RTD: 2 or 3-wire, Minco types PD or PE (100  $\Omega$  EN60751 platinum).  
Thermocouple: Type J (factory default), K, T (selectable).

### Input impedance:

Thermocouple: 3 megohms minimum.  
RTD current: 200  $\mu$ A maximum.

**Sensor break or short protection:** De-energizes control outputs to protect system.

**Loop break protection:** Error message is initiated and output is turned off in case of shorted sensor or open heater circuit. Break time adjustable from OFF to 99 minutes.

**Cycle rate:** 1 to 80 seconds.

**Setpoint range:** Selectable from -212 to 1371°C (-350 to 2500°F), input dependent.

**Display:** One 4 digit, 7 segment, 0.3" high LED. Display shows the measured temperature unless a control key is pressed, then it will display the item value.

**Control action:** Reverse (usually heating) or Direct (usually cooling), selectable.

**Ramp/Soak:** One ramp, 0 to 100 hours.

▼ = **STANDARD OPTIONS**  
Specifications subject to change

## Specifications continued

**Accuracy:**  $\pm 0.25\%$  of span  $\pm 1$  count.

**Resolution:**  $1^\circ$  or  $0.1^\circ$ , selectable.

**Line voltage stability:**  $\pm 0.05\%$  over supply voltage range.

**Temperature stability:**  $4 \mu V/^\circ C$  ( $2.3 \mu V/^\circ F$ ) typical,  $8 \mu V/^\circ C$  ( $4.5 \mu V/^\circ F$ ) max. ( $100 \text{ ppm}/^\circ C$  typical,  $200 \text{ ppm}/^\circ C$  max.).

**Isolation:** Relay and SSR outputs are isolated. Pulsed voltage output must not share a common ground with the input.

**Supply voltage:** 100 to 240 VAC nom.,  $+10/-15\%$ , 50 to 400 Hz, single phase; 132 to 240 VDC, nom.,  $+10/-20\%$ . 5 VA maximum.

**Note:** Do not confuse controller power with heater power. The controller does not supply power to the heater, but only acts as a switch. For example, the controller could be powered by 115 VAC, but controlling 12 VDC to the heater.

**Operating temperature range:**  $-10$  to  $55^\circ C$  ( $14$  to  $131^\circ F$ ).

**Memory backup:** Non-volatile memory (no batteries required).

### Control output ratings:

AC SSR (SPST): 3.5 A @ 250 VAC @  $25^\circ C$  ( $77^\circ F$ ); derates to 1.25 A @  $55^\circ C$  ( $131^\circ F$ ).

Minimum 48 VAC and 100mA required.

An SSR is recommended for longer life than a mechanical relay.

Switched voltage (non-isolated):

5 VDC @ 25 mA.

Mechanical relay, SPST Form A (Normally Open):

3 A resistive, 1.5 A inductive @ 250 VAC;  
pilot duty: 250 VA; 2 A @ 125 VAC or  
1 A @ 250 VAC.

Alarm relay, SPST Form A (Normally Open):

3 A resistive, 1.5 A inductive @ 250 VAC;  
pilot duty: 250 VA; 2 A @ 125 VAC or  
1 A @ 250 VAC.

**Weight:** 227g (8 oz.).

**Agency approvals:** UL & CSA.

**Front panel rating:** Type 4X (IP66).

## Specification and order options

CT15	Model number
1	Alarm: 0 = No 1 = Yes
2	Input: 1 = J, K, or T thermocouple 2 = $100 \Omega$ platinum RTD, type PD or PE
1	Output: 1 = Built-in AC SSR 2 = Pulsed voltage (5 VDC) 3 = Mechanical relay
CT15121 = Sample part number	

*Note:* See page 4-37 for controller accessories.

## Dimensions shown in inches (mm)

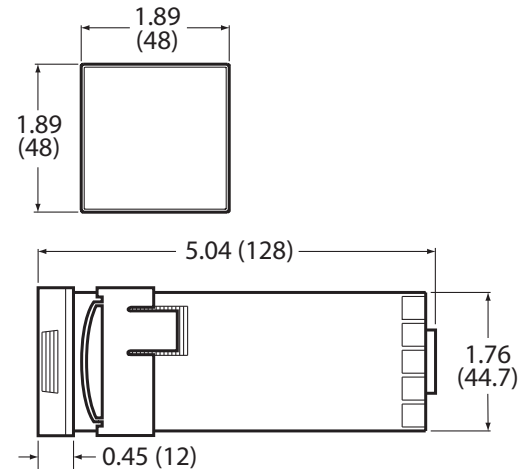

PANEL CUTOUT: 1.775"  $\times$  1.775" (45 mm  $\times$  45 mm)  
 MAXIMUM PANEL THICKNESS: 0.25" (6.35 mm)  
 DIMENSIONS IN INCHES (mm)



**STOCKED PARTS AVAILABLE**

*Specifications subject to change*

# CT16A Temperature Controller



CT16A Controller

## Overview

This economical controller packs sophisticated PID control into a compact  $\frac{1}{16}$  DIN enclosure. A wide range of control modes, sensor input types, and relay or SSR outputs give versatile control of Thermofoil™ heaters and lets you easily connect to other electronics.

- Dual displays continuously show the set point and the actual temperature reading in resolutions of 1°, 0.1°, or engineering units
- Universal Input fits any sensor: Select from 10 thermocouple types, 4 RTD types, voltage, and current signals
- Isolated Outputs for safe, easy wiring
- Loop Break protection handles sensor or heater failure
- Peak / Valley records the maximum and minimum temperatures
- Front panel is waterproof and corrosion-resistant, making it ideal for sanitary applications. Illuminated keypad for easy operation
- Limit the temperatures which the operator can set via four password-protected Security Levels
- Controller can Self-Tune for best PID control
- Control modes: Self-Tune, pre-set or adjustable PID values, simple On/Off control, and open loop
- Fuzzy Logic provides better response time and reduces overshoot in processes with unpredictable inputs
- Alarms at one or two temperatures
- Alarm Relay option is programmable for high, low, absolute, or deviation, can be reset manually or automatically, and controls a single electromechanical relay with voltage-free contacts

- Ramp & Soak option handles complex heating profiles of 16 segments with front-panel activation and a selectable time base (CT16A3)
- Auto / Manual option easily switches to manual control for set up or experiments (CT16A3)
- RS-232 or RS-485 Serial Communications access the temperature readings and all control parameters (optional)
- Retransmit either the sensed temperature or the set point as a voltage or current signal to a computer or recorder (optional)
- 4-Stage Set Point to quickly switch from one temperature to the next (optional)

## Specifications

### Selectable inputs:

RTD: 2 or 3-wire, Minco types  
PD or PE (100  $\Omega$  EN60751 platinum),  
PA (100  $\Omega$  NIST platinum),  
PF (1000  $\Omega$  EN60751 platinum), or  
NA (120  $\Omega$  Nickel).

Thermocouple: Type J (factory default), K, T, L, E, R, S, B, C, or N.  
DC current: 0-20 mA or 4-20 mA (use with Temptran™ transmitters).  
DC voltage: 0-10 or 2-10 VDC, -10 to 10 mVDC, scalable.

### Input impedance:

Voltage: 5000  $\Omega$ .  
Thermocouple: 3 megohms minimum.  
Current: 10  $\Omega$ .  
RTD current: 200  $\mu$ A.

▼ = **STANDARD OPTIONS**  
Specifications subject to change

## Specifications continued

### Sensor break or short protection:

Selectable output: disabled, average output before fault, or preprogrammed output.

Adjustable delay: 0.0 to 540.0 minutes.

**Loop break protection:** Error message is initiated and output is turned off in case of shorted sensor or open heater circuit.

Break time adjustable from OFF to 9999 seconds.

**Cycle rate:** 1 to 80 seconds.

**Setpoint range:** Selectable from -212 to 2320°C (-350 to 4208°F), input dependent.

**Displays:** Two, 4 digit, 7 segment, 0.3" high LEDs. Process Value red, Setpoint Value green. °C or °F.

**Control action:** Reverse (usually heating) or Direct (usually cooling), selectable.

**Ramp/soak:** (CT16A3 only) 16 separate ramp and soak times are adjustable in minutes or seconds from 0 to 9999. When the program has ended, you may choose to repeat, hold, revert to local setpoint, or turn the outputs off.

**Accuracy:** ±0.25% of span ±1 count.

**Resolution:** 1° or 0.1°, selectable.

**Line voltage stability:** ±0.05% over supply voltage range.

**Temperature stability:** 4  $\mu\text{V}/^\circ\text{C}$  (2.3  $\mu\text{V}/^\circ\text{F}$ ) typical, 8  $\mu\text{V}/^\circ\text{C}$  (4.5  $\mu\text{V}/^\circ\text{F}$ ) max. (100 ppm/°C typical, 200 ppm/°C max.).

### Isolation:

Relay and SSR: 1500 VAC to all other inputs and outputs.

SP1 and SP2 current and voltage: 500 VAC to all other inputs and outputs, but not isolated from each other.

Process output (options 934, 936): 500 VAC to all other inputs and outputs.

**Supply voltage:** 100 to 240 VAC nom., +10/-15%, 50 to 400 Hz, single phase; 132 to 240 VDC, nom., +10/-20%. 5 VA maximum.

*Note:* Do not confuse controller power with heater power. The controller does not supply power to the heater, but only acts as a switch. For example, the controller could be powered by 115 VAC, but controlling 12 VDC to the heater.

### Operating temperature range:

-10 to 55°C (14 to 131°F).

**Memory backup:** Non-volatile memory (no batteries required).

### Control output ratings:

AC SSR (SPST): 2.0 A combined outputs

A & B @ 240 VAC @ 25°C (77°F);

derates to 1.0 A @ 55°C (131°F).

An SSR is recommended for longer life than a mechanical relay.

Mechanical relay, SPST Form A (Normally Open) or Form B (Normally Closed):

3 A resistive, 1.5 A inductive @ 240 VAC;

pilot duty: 240 VA; 2 A @ 120 VAC or 1 A @ 240 VAC.

Switched voltage (isolated): 15 VDC @ 20 mA.

Current (isolated): 0 to 20 mA, 600  $\Omega$  max.

DC SSR: 1.75 A @ 32 VDC max.

Alarm relay, SPST Form A (Normally Open):

3 A @ 240 VAC resistive;

1/10 HP @ 120 VAC.

## Specifications and order options

CT16A	Model number
2	Feature set: 2 = Standard 3 = Enhanced (ramp & soak, Auto/manual)
1	Alarm relay: 0 = No 1 = Yes
1	Output A: 1 = Built-in AC SSR 2 = Pulsed voltage (15 VDC) for external SSR 3 = Mechanical relay, SPST (normally open) 4 = Mechanical relay, SPST (normally closed) 5 = Current 8 = DC SSR
0	Output B: 0 = None 1 = Built-in AC SSR 2 = Pulsed voltage (15 VDC) for external SSR 3 = Mechanical relay, SPST (normally open) 4 = Mechanical relay, SPST (normally closed) 5 = Current
-948	Options on next page (leave blank for none)
CT16A2110-948 = Sample part number	

See page 4-37 for Accessories.

▼ = STANDARD OPTIONS

Specifications subject to change

# CT16A - Options and Accessories

## Dimensions shown in inches (mm)

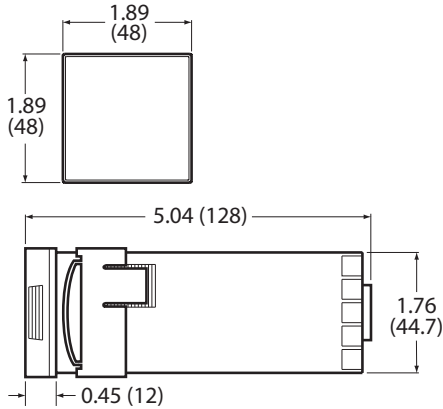

PANEL CUTOUT: 1.775" x 1.775" (45 mm x 45 mm)  
 MAXIMUM PANEL THICKNESS: 0.25" (6.35 mm)

## Additional options for CT16A (board level)

**934: Analog retransmission of Process Variable or Set Variable:** (4 to 20 mA DC) For use as recorder, transmitter or computer A/D input. Linearized 4 to 20 mA DC signal follows the Process or Set variable. Scalable.

**936: Analog retransmission of Process Variable or Set Variable:** (0 to 10 VDC) Similar to option 934, but output signal is linearized 0 to 10 VDC.

**948: 4-Stage setpoint:** Four preset setpoints may be selected by external contacts. Each set point has its own set of PID values giving controller 4 distinct "recipes" for different process situations.

**992: RS-485 Computer communication link:** Allows remote computer to read and write all control parameters.

**993: RS-232 Computer communication link:** Allows remote computer to read and write all control parameters.

## Accessories for CT15 and CT16A

**AC744:** 1-10 A, 24 to 280 VAC SSR

**AC745:** 1-25 A, 24 to 280 VAC SSR

**AC746:** 1-50 A, 24 to 280 VAC SSR

**AC1009:** 1-20 A, 0 to 100 VDC SSR

**AC743:** SSR heat sink for high current or ambient temperature

**AC996 R/C Snubber:** Highly recommended to prolong relay contact life if using the mechanical relay or SSR output to drive a relay or solenoid. Also, for the CT16A AC SSR output, make sure that the coil HOLDING current is greater than 100 mA and voltage is minimum 48 VDC.

**AC1001:** Steel 1/16 to ¼ DIN adapter plate. 127 x 127 mm gray steel with 45 x 45 mm centered hole.



▼ = **STANDARD OPTIONS**  
 Specifications subject to change

# CT425 Temperature Controller

Versatile, configurable controller with Bluetooth option

## Overview

Minco's CT425 Temperature Controller provides simple, yet quick customization for most controller applications. The CT425 Temperature Controller features three user-configurable outputs, two programmable inputs, and communication via USB.

Minco's CT425 Temperature Controller is a PID temperature controller capable of reading two independent temperature sensors (RTDs). By utilizing an internal solid state relay, logic voltage output, and internal mechanical relay, the controller is fully configurable. Simply connect the CT425 to a laptop or PC to configure.

## Features

Flexible configuration for:

### Inputs:

- Utilize one or two Platinum RTDs
- Choose 100 or 1000 ohm RTDs (independently programmable)

### Outputs:

- Utilize up to three outputs
  - Solid state relay
  - Logic voltage
  - Mechanical relay
- Choose control type
  - PID
  - On/Off (mechanical relay only)
  - Alarm
- USB and a user-friendly software package allow for easy setup and use
- 32-bit microprocessor executes both PID loops simultaneously at individually configurable rates up to 25 times/second
- High current capacity internal switching
- Electrically isolated switching outputs increase high voltage safety
- AC powered models perform zero-cross detection to reduce switching noise
- LED indicators provide a quick confirmation of correct sensors input operation



## Applications

The CT425 is designed for a variety of applications that include heating and cooling of equipment or processes. The CT425's versatility makes it ideal to use as an off-the-shelf prototyping tool or as an economical controller for small to medium volume applications. Moreover, the CT425's modular design provides the platform for fast and cost-effective custom designs for medium to high volume applications.

## Bluetooth option

The controller may be ordered with Bluetooth communication (Bluetooth Low Energy, Class 2). The Bluetooth may be used to view real-time data and make basic setting changes.

▼ = **STANDARD OPTIONS**  
Specifications subject to change

## Specifications

CT425 Temperature Controller					
Performance	Measurement Range	-70°C to 650°C (-94°C to 1202°F), 0.25°C full-range accuracy at 25°C			
	Input Power	Model CT425A: 120VAC, 50-60Hz Model CT425B: 10.5-60VDC Model CT425C: 240VAC, 50-60Hz			
	Sensor Inputs (RTD)	100Ω or 1000Ω Platinum, 0.00385Ω/Ω°C TCR, 2-wire connection, Open and shorted sensor detection			
	Connections	5mm spacing terminal block			
Environment	Output Ratings	Output	Max Voltage	Current (25C)	Current (55C)
		120VAC Solid State (CT425A)	120VAC	6A	5A
		DC Solid State (CT425B)	60VDC	15A	11A
		240VAC Solid State (CT425C)	240VAC	3A	2.5A
		Mechanical Relay	250VAC/30VDC	10A resistive	
	Logic Voltage	4.4V, +/- 0.1V output	26mA, +/- 3mA		
Temperature Range	-20°C to 55°C, 90% humidity, non-condensing				
Mechanical	Dimensions	5.46" x 3.34" x 1.22"			
	Weight	350 grams (12.3 ounces)			
	Enclosure	UL 94V-0 ABS plastic with epoxy potting			

## Ordering Information

To configure your temperature controller, select from the options listed below to determine the complete part number.

CT425	Power Supply
CT425A	120VAC power, 120 VAC solid state relay
CT425B	10.5–60VDC power, DC solid state relay
CT425C	240VAC power, 240 VAC solid state relay
Additional Option: -BT Blank for none	Bluetooth Communication
CT425A, CT425A-BT = Sample part number	

▼ = **STANDARD OPTIONS**  
Specifications subject to change







## ▶ SECTION 6: MINIATURE SENSORS

- Embedment sensors install in bearings for over-temperature protection
- Small, rugged RTDs and thermocouples withstand rough handling and harsh environments
- Certified non-sparking sensors for hazardous areas
- Bolt-on designs for easy installation

Embedment RTDs.....	6-2
Embedment Thermocouples.....	6-3
Increased Safety and Intrinsically Safe Embedment Sensors .....	6-4 to 6-5
Non-sparking Embedment Sensors .....	6-6 to 6-9
Bolt-on sensors .....	6-10
Economy sensors.....	6-11
Installation and accessories .....	6-12

# Embedment RTDs

Element	TCR $\Omega/\Omega/^{\circ}\text{C}$	Case style A		Case style B		Case style C		Case style D	
		Single	Dual	Single	Dual	Single	Dual	Single	Dual
Platinum, 100 $\Omega$ $\pm 0.36\%$ at 0°C	.00392	S325PA, S11636PA*	S4026PA	S331PA	S7792PA	S341PA	S14320PA	S12414PA	
Platinum, 100 $\Omega$ $\pm 0.12\%$ at 0°C (Meets EN60751, Class B)	.00385	S304PD	S309PD	S306PD	S14405PD	S308PD	S14455PD	▼ S13282PD	
Platinum, 100 $\Omega$ $\pm 0.36\%$ at 0°C	.00385	S7304PE	S305PE	S7746PE	S307PE	S7908PE	S14456PE	S13282PE	
Platinum, 1000 $\Omega$ $\pm 0.12\%$ at 0°C	.00385	S101907PF	S101911PF	S101908PF	S101912PF	S101909PF	S101913PF	S101910PF	
Copper, 10 $\Omega$ $\pm 0.2\%$ at 25°C	.00427	S324CA	S4026CA	S332CA		S342CA			
Nickel, 120 $\Omega$ $\pm 0.5\%$ at 0°C	.00672	S326NA, S11636NA*	S4026NA	S330NA	S7792NA	S340NA			

\*MIL-T-24388C qualified models

## Overview

Install miniature sensors in or beneath the babbitt layer of bearing shoes. They monitor metal temperature — the most reliable indicator of bearing condition — to give early warning of oil film breakdown. Machines can then be shut down and the problem corrected before catastrophic failure occurs.

While no larger than many bare ceramic elements, these RTDs have metal cases and insulated leads to withstand rough handling and harsh environments. They are easy to install in drilled holes for general purpose sensing.

## Specifications

**Temperature range:** -50 to 260°C (-58 to 500°F).

**Case:** Tin plated copper alloy. Models S12414, S13282 and S101910: Stainless steel.

**Babbitt tip:** Factory applied babbitt tip, available on case style A or B, reduces the danger of overheating the sensor when installed in babbitt layer.

**Leads:** Stranded copper with PTFE insulation; stainless steel overbraid optional (one sleeve covers all leads). Polyimide insulation available on selected models (See specification and order options).

**Time constant:** 3.0 seconds (case style A) to 1.5 seconds (case style D), typical value in moving water.

**Insulation resistance:** 10 megohms min. at 100 VDC, leads to case.

\*MIL-T-24388C qualified models:

PRT-EM-E2: Order S11636PA3K36B1.

NRT-EM-E1: Order S11636NA3K36B1.

▼ = **STANDARD OPTIONS**

Specifications subject to change

### Leadwire size (AWG):

Case style	Number of leads			
	2	3	4	6
A	24	24	24	24
B	24	24	28	28
C	24	26	30	30
D	30	30	34	



**STOP OIL SEEPAGE!**



**STOCKED PARTS AVAILABLE**

## Specification and order options

S331PA	Model number from table
3	Number of leads per sensing element (2, ▼3, or 4): ▼:3 CA or PD elements not available with 2 leads. 4 leads available on single elements and S14405 only.
S	<b>Covering over leadwires:</b> ▼ T = PTFE insulated leads only ▼ S = Stainless steel overbraid with PTFE insulated leads F = FEP over PTFE insulated leads R = FEP over stainless steel braid and PTFE insulated leads. E = FEP over stainless steel braid, with elastomer fill and PTFE insulated leads. (max fill length 240") <b>S11636 Covering options only:</b> K = Polyimide insulated leads. S = Stainless steel overbraid with polyimide insulated leads.
120	Lead length in inches: ▼120
(Stop here for case style C or D; no installation variable)	
AC1	<b>Optional Installation/Accessory option:</b> B0 = No babbitt metal or accessories B1 = Babbitt metal applied AC1 = Supplied with AC171 spring and AC172 series ring (case style B only) AC2 = Supplied with AC171 spring and AC1038 ring (case style B only) AC3 = Supplied with AC171 spring and AC915-1 ring (case style B only)
S331PA3S120AC1 = Sample part number	

# Embedment Thermocouples

Leadwire	Case style A Case L: 0.250" (6.4 mm) Case Ø: 0.275" (7.0 mm)		Case style B Case L: 0.250" (6.4 mm) Case Ø: 0.188" (4.8 mm) Flange Ø: 0.250" (6.4 mm)		Case style C Case L: 0.300" (7.6 mm) Case Ø: 0.125" (3.2 mm)		Case style D Case L: 0.300" (7.6 mm) Case Ø: 0.080" (2.0 mm)	
	Single	Dual	Single	Dual	Single	Dual	Single	Dual
AWG 20 stranded	TC311	TC312	TC333					
AWG 24 stranded	TC2162	TC2303	TC2084	TC2096	TC344	TC2623		
AWG 24 stranded with single SS braid over both wire pairs		TC2698		TC2520		TC2837		
AWG 30 solid							▼TC2741	

## Overview

These thermocouples are mechanically interchangeable with the RTDs on pages 6-2 and 6-3.

## Specifications

**Temperature range:** -184 to 260°C (-300 to 500°F).

Copper-Constantan (Type T):

AWG 24: 200°C (392°F) maximum,

AWG 30: 150°C (302°F) maximum.

**Time constant:** Typical value in moving water:

Grounded junction: 0.3 seconds.

Ungrounded junction: 6 seconds (case style A) to 1 second (case style C).

**Insulation resistance:** 10 megohms min. at 100 VDC, leads to case, ungrounded junctions only.

**Case:** Tin plated copper alloy.

**Babbitt tip:** Factory applied babbitt tip, available on case styles A and B, reduces the danger of overheating the sensor when installed in babbitt layer.

**Leads:** See table for sizes and options. Dual element models with AWG 24 stranded leadwires are available with a single stainless steel braid over all four wires. This option is recommended for use with integral feedthroughs. See below for more information.

## Specification and order options

TC311	Model number from table
E	Junction type: ▼ E = Chromel-Constantan      ▼ K = Chromel-Alumel ▼ J = Iron-Constantan          ▼ T = Copper-Constantan
U	Junction grounding: ▼ G = Grounded                  ▼ U = Ungrounded
36	Lead length in inches ▼: 48, 144
S	Covering over leadwires: T = PTFE insulated leads only ▼ S = Stainless steel overbraid with PTFE insulated leads F = FEP over PTFE insulated leads R = FEP over stainless steel braid and PTFE insulated leads E = FEP over stainless steel braid, with elastomer fill and PTFE insulated leads (max fill length 240")
(Stop here for case style C or D; no installation variable)	
B0	Optional Installation/Accessory option: B0 = No babbitt metal or accessories B1 = Babbitt metal applied AC1 = Supplied with AC171 spring and AC172 series ring (case style B only) AC2 = Supplied with AC171 spring and AC1038 ring (case style B only) AC3 = Supplied with AC171 spring and AC915-1 ring (case style B only)
TC311EU36SB0 = Sample part number	

## STOP OIL SEEPAGE!

**Feedthroughs** provide an oil tight seal where a cable exits a machine housing. The stainless steel tube is epoxy filled and each wire is sealed to the individual conductor. This prevents wicking of oil inside the wires as well as leakage around the wire insulation. Pressure rating to 25 psi (1.7 bar.) See page 3-11 for details.

**Leadwire and cable seal** models FG1015, FG3015 and FG4015 seal RTD or thermocouple leadwires where they exit oil-filled bearing housings of rotating equipment. Both versions include a grommet that provides the seal and allows adjustment of the wire or cable position. See page 3-12 for details.

**Elastomer rubber-filled cable** has elastomer fill between the wires, stainless steel braid, and outer jacket. This fill can extend along the entire length of the cable, or a specified portion. The outside of the cable can be sealed with an FG1015, FG3015 and FG4015 fitting. See Leadwire Covering Options on Miniature Sensors on pages 6-2 to 6-10.

For more information on the problems of oil seepage and various solutions, visit [www.minco.com](http://www.minco.com)



▼ = STANDARD OPTIONS  
Specifications subject to change

# Increased Safety & Intrinsically Safe Embedment Sensors

**ATEX**  **II 2 G Ex e IIC**

**ATEX**  **II 1 G Ex ia IIC**

**IECEx Ex eb IIC**

**IECEx Ex ia IIC**

**EAC**



## Overview

- Increased safety and intrinsically safe embedment sensors for monitoring the temperature of thrust bearings
- Three case styles offer a variety of installation options
- Certified for use in Zone 0 and Zone 1, Group IIC hazardous areas, defined by IEC 60079-0 and IEC 60079-7

## Specifications

**Temperature range:** -50 to 200°C (-58 to 392°F), reducing to 125°C (257°F) when elastomer filled cable is ordered.

**Case:** Tin plated copper alloy.

**Babbitt tip:** Factory applied babbitt tip, available on case style A and B reduces the danger of overheating the sensor when installed in babbitt layer.

### Leads:

**RTD:** stranded copper with PTFE insulation.

Stainless steel braid, FEP over PTFE and FEP over stainless steel braid with elastomer fill are optional.

**Thermocouple:** stranded, PTFE insulated, twisted pairs.

Stainless steel braid, FEP over PTFE and FEP over stainless steel braid with elastomer fill are optional.

### Leadwire size (AWG):

RTD					
Case style	Number of leads				
	2	3	4	6	8
A	24	24	24	24	
B	24	24	28	28	28
C	24	26	30	30	
D	30	30	34		
Thermocouple					
A, B, C	24		24		
D	30				

**Time constant:** 3.0 seconds (case style A), typical in moving water.

**Insulation resistance:** 10 megohms minimum at 100 VDC, leads to case.

▼ = **STANDARD OPTIONS**





*Specifications subject to change*





## Specification and order options: RTD

S102951PD	Model number from next page
3	Number of leads per sensing element (2, 3 or 4): ▼:3 CA or PD elements not available with 2 leads 4 leads available on all single elements and dual S207596 + S207598 only
E	<b>Covering over leadwires:</b> T = PTFE insulated leads only ▼ S = Stainless steel overbraid with PTFE insulated leads F = FEP over PTFE insulated leads ▼ E = FEP over stainless steel braid, with elastomer fill and PTFE insulated leads (max. fill length 240")
36	<b>Lead length in inches</b> ▼:36, 120
<b>(Stop here for case style C; no installation variable)</b>	
AC1	<b>Optional Installation/Accessory option</b> ▼ B0 = No babbitt metal or accessories ▼ B1 = Babbitt metal applied ▼ AC1 = Supplied with AC171 spring and AC172 series ring (case style B only) AC2 = Supplied with AC171 spring and AC1038 ring (case style B only) AC3 = Supplied with AC171 spring and AC915-1 ring (case style B only)
S102951PD3E36AC1 = Sample part number	

## Specification and order options: Thermocouple

TC102960K	Model number from next page
U	<b>Junction grounding:</b> ▼ G = Grounded ▼ U = Ungrounded
48	<b>Lead length in inches</b> ▼:48, 144
S	<b>Covering over leadwires:</b> T = PTFE insulated leads only ▼ S = Stainless steel overbraid with PTFE insulated leads F = FEP over PTFE insulated leads ▼ E = FEP over stainless steel braid, with elastomer fill and PTFE insulated leads (max fill length 240")
<b>(Stop here for case style C; no installation variable)</b>	
B0	<b>Optional Installation/Accessory option</b> ▼ B0 = No babbitt metal or accessories ▼ B1 = Babbitt metal applied ▼ AC1 = Supplied with AC171 spring and AC172 series ring (case style B only) AC2 = Supplied with AC171 spring and AC1038 ring (case style B only) AC3 = Supplied with AC171 spring and AC915-1 ring (case style B only)
TC102960KU48SB0 = Sample part number	

RTD Element	TCR $\Omega/\Omega/^{\circ}\text{C}$	Case style A Case L: 0.250" (6.4 mm) Case $\varnothing$ : 0.275" (7.0 mm) 		Case style B Case L: 0.250" (6.4 mm) Case $\varnothing$ : 0.188" (4.8 mm) Flange $\varnothing$ : 0.250" (6.4 mm) 		Case style C Case L: 0.300" (7.6 mm) Case $\varnothing$ : 0.125" (3.2 mm) 		Case style D Case L: 0.300" (7.6 mm) Case $\varnothing$ : 0.080" (2.0 mm) 
		Single	Dual	Single	Dual	Single	Dual	Single
▼ Platinum, 100 $\Omega$ $\pm$ 0.36% at 0°C	.00392	S102950	S102950	S102951	S102951	S102952	S102952	S102954 * Zone 0 only
▼ Platinum, 100 $\Omega$ $\pm$ 0.12% at 0°C (Meets EN60751, Class B)	.00385							
▼ Platinum, 100 $\Omega$ $\pm$ 0.067% at 0°C (Meets EN60751, Class A)	.00385							
▼ Platinum, 100 $\Omega$ $\pm$ 0.36% at 0°C	.00385							
▼ Platinum, 1000 $\Omega$ $\pm$ 0.12% at 0°C	.00385							
▼ Copper, 10 $\Omega$ $\pm$ 0.2% at 25°C	.00427							
▼ Nickel, 120 $\Omega$ $\pm$ 0.5% at 0°C	.00672							Not Available

Thermocouple Junction Type	Case style A Case L: 0.250" (6.4 mm) Case $\varnothing$ : 0.275" (7.0 mm) 		Case style B Case L: 0.250" (6.4 mm) Case $\varnothing$ : 0.188" (4.8 mm) Flange $\varnothing$ : 0.250" (6.4 mm) 		Case style C Case L: 0.300" (7.6 mm) Case $\varnothing$ : 0.125" (3.2 mm) 		Case style D Case L: 0.300" (7.6 mm) Case $\varnothing$ : 0.080" (2.0 mm) 
	Single	Dual	Single	Dual	Single	Dual	Single
E = Chromel-Constantan	▼ TC102960	▼ TC102960	▼ TC102961	▼ TC102961	TC102962	TC102962	TC102964 *Zone 0 only
J = Iron-Constantan							
K = Chromel-Alumel							
T = Copper-Constantan							

**STOP OIL SEEPAGE!**

**Feedthroughs** provide an oil tight seal where a cable exits a machine housing. The stainless steel tube is epoxy filled and each wire is sealed to the individual conductor. This prevents wicking of oil inside the wires as well as leakage around the wire insulation. Pressure rating to 25 psi (1.7 bar.) See page 3-11 for details.

**Leadwire and cable seal** models FG1015, FG3015 and FG4015 seal RTD or thermocouple leadwires where they exit oil-filled bearing housings of rotating equipment. Both versions include a grommet that provides the seal and allows adjustment of the wire or cable position. See page 3-12 for details.

**Elastomer rubber-filled cable** has elastomer fill between the wires, stainless steel braid, and outer jacket. This fill can extend along the entire length of the cable, or a specified portion. The outside of the cable can be sealed with an FG1015, FG3015 and FG4015 fitting. See Leadwire Covering Options on Miniature Sensors on pages 6-2 to 6-10.



Minco Application Aid #27 provides more information on the problems of oil seepage and various solutions. Download AA#27 at [www.minco.com](http://www.minco.com)

▼ = STANDARD OPTIONS  
Specifications subject to change

# Non-sparking Embedment Sensors - Self Certified



**ATEX**  
**II 3 G Ex nA IIC u**



## Overview

- Non-sparking embedment sensors for monitoring the temperature of thrust bearings
- Four case styles offer a variety of installation options
- Certified for use in Zone 2, Group IIC hazardous areas

## Specifications

**Temperature range:** -50 to 200°C (-58 to 392°F), reducing to 125°C (257°F) when elastomer filled cable is ordered.

**Case:** Tin plated copper alloy.

**Babbitt tip:** Factory applied babbitt tip, available on case style A, B, and short style B, reduces the danger of overheating the sensor when installed in babbitt layer.

### Leads:

**RTD:** stranded copper with PTFE insulation.

Stainless steel braid, FEP over PTFE and FEP over stainless steel braid with elastomer fill are optional.

**Thermocouple:** stranded, PTFE insulated, twisted pairs.

Stainless steel braid, FEP over PTFE and FEP over stainless steel braid with elastomer fill are optional.

### Leadwire size (AWG):

RTD					
Case style	Number of leads				
	2	3	4	6	8
A	24	24	24	24	
B	24	24	28	28	28
C	24	26	30	30	
Short B	24	26	28	30	
Thermocouple					
All cases	24		24		

**Time constant:** 3.0 seconds (case style A), typical in moving water.

**Insulation resistance:** 10 megohms minimum at 100 VDC, leads to case.

### ▼ = STANDARD OPTIONS

Specifications subject to change





## Specification and order options:



### RTD

S102617PD	Model number from next page
3	<b>Number of leads per sensing element (2, 3 or 4):</b> CA or PD elements not available with 2 leads 4 leads available on all single elements and dual S102618 and S102662 only
F	<b>Covering over leadwires:</b> T = PTFE insulated leads only S = Stainless steel overbraid with PTFE insulated leads F = FEP over PTFE insulated leads E = FEP over stainless steel braid with elastomer fill and PTFE Insulated leads (max. fill length 240")
48	<b>Lead length in inches</b>
(Stop here for case style C or D; no installation variable)	
B0	<b>Optional Installation/Accessory option:</b> B0 = No babbitt metal or accessories B1 = Babbitt metal applied AC1 = Supplied with AC171 spring and AC172 series ring (case style B only) AC2 = Supplied with AC171 spring and AC1038 ring (case style B only) AC3 = Supplied with AC171 spring and AC915-1 ring (case style B only)
S102617PD3F48B0 = Sample part number	

### Thermocouple

TC102621E	Model number from next page
U	<b>Junction grounding:</b> G = Grounded U = Ungrounded
48	<b>Lead length in inches</b>
F	<b>Covering over leadwires:</b> T = PTFE insulated leads only S = Stainless steel overbraid with PTFE insulated leads F = FEP over PTFE insulated leads E = FEP over stainless steel braid with elastomer fill and PTFE Insulated leads (max. fill length 240")
(Stop here for case style C or D; no installation variable)	
B0	<b>Optional Installation/Accessory option:</b> B0 = No babbitt metal or accessories B1 = Babbitt metal applied AC1 = Supplied with AC171 spring and AC172 series ring (case style B only) AC2 = Supplied with AC171 spring and AC1038 ring (case style B only) AC3 = Supplied with AC171 spring and AC915-1 ring (case style B only)
TC102621EU48FB0 = Sample part number	

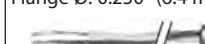
RTD Element	TCR $\Omega/\Omega/^{\circ}\text{C}$	Case style A Case L: 0.250" (6.4 mm) Case $\varnothing$ : 0.275" (7.0 mm) 		Case style B Case L: 0.250" (6.4 mm) Case $\varnothing$ : 0.188" (4.8 mm) Flange $\varnothing$ : 0.250" (6.4 mm) 		Case style C Case L: 0.300" (7.6 mm) Case $\varnothing$ : 0.125" (3.2 mm) 		Short case style B Case L: .188" (4.8 mm) Case $\varnothing$ : .188" (4.8 mm) Flange $\varnothing$ : 0.250" (6.4 mm) 	
		Single	Dual	Single	Dual	Single	Dual	Single	Dual
Platinum, 100 $\Omega$ $\pm$ 0.36% at 0°C	.00392	S102617PA	S102617PAPA	S102618PA	S102618PAPA	S102619PA	S102619PAPA	S102662PA	S102662PAPA
Platinum, 100 $\Omega$ $\pm$ 0.12% at 0°C (Meets EN60751, Class B)	.00385	S102617PD	S102617PDPD	S102618PD	S102618PDPD	S102619PD	S102619PDPD	S102662PD	S102662PDPD
Platinum, 100 $\Omega$ $\pm$ 0.36% at 0°C	.00385	S102617PE	S102617PEPE	S102618PE	S102618PEPE	S102619PE	S102619PEPE	S102662PE	S102662PEPE
Platinum, 1000 $\Omega$ $\pm$ 0.12% at 0°C	.00385	S102617PF	S102617PFPF	S102618PF	S102618PFPF	S102619PF	S102619PFPF	S102662PF	S102662PFPF
Copper, 10 $\Omega$ $\pm$ 0.2% at 25°C	.00427	S102617CA	S102617CACA	S102618CA		S102619CA		S102662CA	
Nickel, 120 $\Omega$ $\pm$ 0.5% at 0°C	.00672	S102617NA	S102617NANA	S102618NA	S102618NANA	S102619NA		S102662NA	S102662NANA

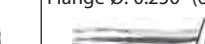
Thermocouple Junction Type	Case style A Case L: 0.250" (6.4 mm) Case $\varnothing$ : 0.275" (7.0 mm) 		Case style B Case L: 0.250" (6.4 mm) Case $\varnothing$ : 0.188" (4.8 mm) Flange $\varnothing$ : 0.250" (6.4 mm) 		Case style C Case L: 0.300" (7.6 mm) Case $\varnothing$ : 0.125" (3.2 mm) 		Short case style B Case L: .188" (4.8 mm) Case $\varnothing$ : .188" (4.8 mm) Flange $\varnothing$ : 0.250" (6.4 mm) 	
	Single	Dual	Single	Dual	Single	Dual	Single	Dual
E = Chromel-Constantan	TC102620E	TC102620EE	TC102621E	TC102621EE	TC102622E	TC102622EE	TC102663E	TC102663EE
J = Iron-Constantan	TC102620J	TC102620JJ	TC102621J	TC102621JJ	TC102622J	TC102622JJ	TC102663J	TC102663JJ
K = Chromel-Alumel	TC102620K	TC102620KK	TC102621K	TC102621KK	TC102622K	TC102622KK	TC102663K	TC102663KK
T = Copper-Constantan	TC102620T	TC102620TT	TC102621T	TC102621TT	TC102622T	TC102622TT	TC102663T	TC102663TT

### STOP OIL SEEPAGE!

**Feedthroughs** provide an oil tight seal where a cable exits a machine housing. The stainless steel tube is epoxy filled and each wire is sealed to the individual conductor. This prevents wicking of oil inside the wires as well as leakage around the wire insulation. Pressure rating to 25 psi (1.7 bar.) See page 3-11 for details.

**Leadwire and cable seal** models FG1015, FG3015 and FG4015 seal RTD or thermocouple leadwires where they exit oil-filled bearing housings of rotating equipment. Both versions include a grommet that provides the seal and allows adjustment of the wire or cable position. See page 3-12 for details.

**Elastomer rubber-filled cable** has elastomer fill between the wires, stainless steel braid, and outer jacket. This fill can extend along the entire length of the cable, or a specified portion. The outside of the cable can be sealed with an FG1015, FG3015 and FG4015 fitting. See Leadwire Covering Options on Miniature Sensors on pages 6-2 to 6-10.

Minco Application Aid #27 provides more information on the problems of oil seepage and various solutions. Download AA#27 at [www.minco.com](http://www.minco.com)



▼ = STANDARD OPTIONS  
Specifications subject to change

# Non-sparking Embedment Sensors

**ATEX**  **II 3 G Ex nA IIC Gc**  
**IECEx Ex nA IIC Gc**

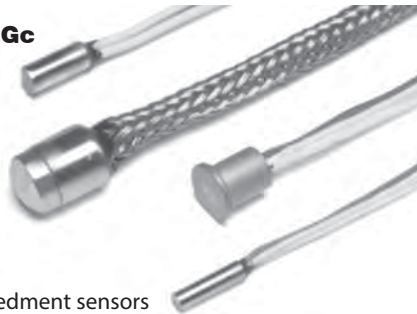

## Overview

- Non-sparking embedment sensors for monitoring the temperature of thrust bearings
- Four case styles offer a variety of installation options
- Certified for use in Zone 2, Group IIC hazardous areas, defined by EN/IEC 60079-0 and EN/IEC 60079-15

## Specifications

**Temperature range:** -50 to 200°C (-58 to 392°F), reducing to 125°C (257°F) when elastomer filled cable is ordered.

**Case:** Tin plated copper alloy.

**Babbitt tip:** Factory applied babbitt tip, available on case style A, B, and short style B, reduces the danger of overheating the sensor when installed in babbitt layer.

### Leads:

**RTD:** stranded copper with PTFE insulation.

Stainless steel braid, FEP over PTFE and FEP over stainless steel braid with elastomer fill are optional.

**Thermocouple:** stranded, PTFE insulated, twisted pairs.

Stainless steel braid, FEP over PTFE and FEP over stainless steel braid with elastomer fill are optional.

### Leadwire size (AWG):

RTD					
Case style	Number of leads				
	2	3	4	6	8
A	24	24	24	24	
B	24	24	28	28	28
C	24	26	30	30	
Short B	24	24	28	28	
Thermocouple					
All cases	24		24		

**Time constant:** 3.0 seconds (case style A), typical in moving water.

**Insulation resistance:** 10 megohms minimum at 100 VDC, leads to case.

▼ = **STANDARD OPTIONS**  
 Specifications subject to change

## Specification and order options:

### RTD

S207596PD	Model number from next page
3	<b>Number of leads per sensing element (2, 3 or 4):</b> CA or PD elements not available with 2 leads 4 leads available on all single elements and dual S207596 + S207598 only
E	<b>Covering over leadwires:</b> T = PTFE insulated leads only S = Stainless steel overbraid with PTFE insulated leads F = FEP over PTFE insulated leads E = FEP over stainless steel braid, with elastomer fill and PTFE insulated leads (max. fill length 240")
40	<b>Lead length in inches</b> ▼:40, 120
(Stop here for case style C; no installation variable)	
AC1	<b>Optional Installation/Accessory option</b> B0 = No babbitt metal or accessories B1 = Babbitt metal applied AC1 = Supplied with AC171 spring and AC172 series ring (case style B only) AC2 = Supplied with AC171 spring and AC1038 ring (case style B only) AC3 = Supplied with AC171 spring and AC915-1 ring (case style B only)
S207596PD3E40AC1 = Sample part number	

### Thermocouple

TC207600K	Model number from next page
U	<b>Junction grounding:</b> G = Grounded U = Ungrounded
40	<b>Lead length in inches</b> ▼:40, 120
S	<b>Covering over leadwires:</b> T = PTFE insulated leads only S = Stainless steel overbraid with PTFE insulated leads F = FEP over PTFE insulated leads E = FEP over stainless steel braid, with elastomer fill and PTFE insulated leads (max fill length 240")
(Stop here for case style C; no installation variable)	
B0	<b>Optional Installation/Accessory option</b> B0 = No babbitt metal or accessories B1 = Babbitt metal applied AC1 = Supplied with AC171 spring and AC172 series ring (case style B only) AC2 = Supplied with AC171 spring and AC1038 ring (case style B only) AC3 = Supplied with AC171 spring and AC915-1 ring (case style B only)
TC207600KU40SB0 = Sample part number	



RTD Element	TCR $\Omega/\Omega/^{\circ}\text{C}$	Case style A Case L: 0.250" (6.4 mm) Case $\varnothing$ : 0.275" (7.0 mm)		Case style B Case L: 0.250" (6.4 mm) Case $\varnothing$ : 0.188" (4.8 mm) Flange $\varnothing$ : 0.250" (6.4 mm)		Case style C Case L: 0.300" (7.6 mm) Case $\varnothing$ : 0.125" (3.2 mm)		Short case style B Case L: .188" (4.8 mm) Case $\varnothing$ : .188" (4.8 mm) Flange $\varnothing$ : 0.250" (6.4 mm)	
		Single	Dual	Single	Dual	Single	Dual	Single	Dual
Platinum, 100 $\Omega$ $\pm$ 0.36% at 0°C	.00392	S207595PA	S207595PAPA	S207596PA	S207596PAPA	S207597PA	S207597PAPA	S207598PA	S207598PAPA
Platinum, 100 $\Omega$ $\pm$ 0.12% at 0°C (Meets EN60751, Class B)	.00385	S207595PD	S207595PDPD	S207596PD	S207596PDPD	S207597PD	S207597PDPD	S207598PD	S207598PDPD
Platinum, 100 $\Omega$ $\pm$ 0.067% at 0°C (Meets EN60751, Class A)	.00385	S207595PM	S207595PMPM	S207596PM	S207596PMPM	S207597PM	S207597PMPM	S207598PM	S207598PMPM
Platinum, 100 $\Omega$ $\pm$ 0.36% at 0°C	.00385	S207595PE	S207595PEPE	S207596PE	S207596PEPE	S207597PE	S207597PEPE	S207598PE	S207598PEPE
Platinum, 1000 $\Omega$ $\pm$ 0.12% at 0°C	.00385	S207595PF	S207595PFPF	S207596PF	S207596PFPF	S207597PF	S207597PFPF	S207598PF	S207598PFPF
Copper, 10 $\Omega$ $\pm$ 0.2% at 25°C	.00427	S207595CA	S207595CACA	S207596CA		S207597CA		S207598CA	
Nickel, 120 $\Omega$ $\pm$ 0.5% at 0°C	.00672	S207595NA	S207595NANA	S207596NA	S207596NANA	S207597NA		S207598NA	S207598NANA

Thermocouple Junction Type	Case style A Case L: 0.250" (6.4 mm) Case $\varnothing$ : 0.275" (7.0 mm)		Case style B Case L: 0.250" (6.4 mm) Case $\varnothing$ : 0.188" (4.8 mm) Flange $\varnothing$ : 0.250" (6.4 mm)		Case style C Case L: 0.300" (7.6 mm) Case $\varnothing$ : 0.125" (3.2 mm)		Short case style B Case L: .188" (4.8 mm) Case $\varnothing$ : .188" (4.8 mm) Flange $\varnothing$ : 0.250" (6.4 mm)	
	Single	Dual	Single	Dual	Single	Dual	Single	Dual
E = Chromel-Constantan	TC207600E	TC207600EE	TC207601E	TC207601EE	TC207602E	TC207602EE	TC207603E	TC207603EE
J = Iron-Constantan	TC207600J	TC207600JJ	TC207601J	TC207601JJ	TC207602J	TC207602JJ	TC207603J	TC207603JJ
K = Chromel-Alumel	TC207600K	TC207600KK	TC207601K	TC207601KK	TC207602K	TC207602KK	TC207603K	TC207603KK
T = Copper-Constantan	TC207600T	TC207600TT	TC207601T	TC207601TT	TC207602T	TC207602TT	TC207603T	TC207603TT

### STOP OIL SEEPAGE!

**Feedthroughs** provide an oil tight seal where a cable exits a machine housing. The stainless steel tube is epoxy filled and each wire is sealed to the individual conductor. This prevents wicking of oil inside the wires as well as leakage around the wire insulation. Pressure rating to 25 psi (1.7 bar.) See page 3-11 for details.

**Leadwire and cable seal** models FG1015, FG3015 and FG4015 seal RTD or thermocouple leadwires where they exit oil-filled bearing housings of rotating equipment. Both versions include a grommet that provides the seal and allows adjustment of the wire or cable position. See page 3-12 for details.





**Elastomer rubber-filled cable** has elastomer fill between the wires, stainless steel braid, and outer jacket. This fill can extend along the entire length of the cable, or a specified portion. The outside of the cable can be sealed with an FG1015, FG3015 and FG4015 fitting. See Leadwire Covering Options on Miniature Sensors on pages 6-2 to 6-10.



Minco Application Aid #27 provides more information on the problems of oil seepage and various solutions. Download AA#27 at [www.minco.com](http://www.minco.com)

▼ = STANDARD OPTIONS  
Specifications subject to change

# Bolt-on Temperature Sensors

	Dimensions W x L x T (max.)	Temp. range	Element options	Case material	Leadwire	Model
	0.50 x 1.00 x 0.188" (12.7 x 25.4 x 4.8 mm) w/ 0.161" (4.1 mm) diameter hole	-70 to 500°C (-94 to 932°F)	PD, PF	Stainless steel	AWG 22, Mica-glass insulated	▼ S101730
	0.29 x 1.25 x 0.188" (7.4 x 31.8 x 4.8 mm) with 0.161" (4.1 mm) hole	-70 to 500°C (-94 to 932°F)	PD, PF	Stainless steel	AWG 22, Mica-glass insulated	▼ S101731
	0.265" (6.7 mm) ID ring lug	-50 to 260°C (-58 to 500°F)	PD, PF	Nickel plated copper	2 lead: AWG 24, 3 lead: AWG 26, PTFE insulated	▼ S101732
	0.50 x 0.375 x 0.188" (12.7 x 9.5 x 4.8 mm) with 0.166" (4.2 mm) hole	-50 to 260°C (-58 to 500°F)	PD, PF	Stainless steel	2 lead: AWG 24, 3 lead: AWG 26, PTFE insulated with SS braid cover	▼ S101733
	1/4" - 20 x 3/8" long thread with 7/16" hex head	-50 to 260°C (-58 to 500°F)	PD, PF	Stainless steel	2 lead: AWG 24, 3 lead: AWG 26, PTFE insulated with SS braid cover	▼ S101734
	M6 x 1 thread, 10 mm long, with 10 mm hex					▼ S101797

## Overview

Bolt-on temperature sensors are designed for easy installation in industrial and commercial environments. The sensors can be mounted on machines, against process pipes, or embedded directly into a machined part. Threaded fasteners install in seconds and can be easily removed for installation at another location.

These sensors are ideal for process control measurements, test and verification of existing systems, and retrofitting existing machines. Standard designs allow prototyping without high setup costs, while significant discounts are available for large quantities.

Standard platinum and nickel RTD elements provide stable and reliable output compatible with most control and monitoring systems. Physically interchangeable designs allow you to easily customize your installation to different instrumentation. Minco can also provide custom RTD, thermistor or thermocouple elements in these packages, or specialized case designs to meet your application needs.

- Removable and reusable
- Wide temperature range
- Configurations to fit most applications
- Standard 100 Ω platinum, 1000 Ω platinum and 100 Ω nickel elements

## Specification and order options:

S101732	Model number from table
PD	Element code from table
3	Number of leads: ▼: 2 or 3 2 leads not recommended for PD models
S	Leadwire covering: ▼ G = Mica-glass (S101730 and S101731) ▼ T = PTFE (S100722, S101732, S101733, S101734, and S101797) ▼ S = Stainless steel braid over PTFE insulated leads (S100722, S101732, S101733, S101734, and S101797)
40	Leadwire length (inches): 40" (1000 mm) standard ▼: 40, 120
S101732PD3S40 = Sample part number	

## Specifications

**Time constant:** Less than 10 seconds in moving water.

**Insulation resistance:** 10 megohms minimum at 100 VDC, leads to case.

**Vibration:** Withstands 10 to 2000 Hz at 20 G's minimum per MIL-STD-202. Method 204, test condition D.

Element specifications*		Code
Platinum (0.00385 TCR) (EN60751, Class B)	100 Ω ±0.12% at 0°C	▼ PD
Platinum (0.00385 TCR)	1000 Ω ±0.12% at 0°C	▼ PF
Nickel 0.00618 TCR)	100 Ω ±0.22% at 0°C	NB









\*See descriptions for element options on each model.



**STOCKED PARTS AVAILABLE**

▼ = **STANDARD OPTIONS**  
Specifications subject to change

# Economy Sensors

	Dimensions	Temperature range	Element options	Case material	Leadwire	Model
	2 leads: .050" x .065" x .035" thick (1.3 x 1.7 x .9 mm) Thin-Film with insulated leads 3 leads: .063" x .098" x .035" thick (1.6 x 2.5 x .9 mm) Thin-Film with insulated leads	-50 to 150°C (-58 to 302°F)	PD, PF	Ceramic	AWG 32 solid enamel insulated	▼ S102404
	Ø .125" x .90" (Ø 3.2 x 22.9 mm)	-50 to 260°C (-58 to 500°F)	PD, PF	Stainless steel	AWG 26, PTFE insulated	▼ S102409
	Ø .125" x .90" (Ø 3.2 x 22.9 mm)	-50 to 155°C (-58 to 311°F)	PD, PF	Stainless steel	AWG 30, PTFE insulated	▼ S102737
	Ø .140" x .40" (Ø 3.6 x 10.2 mm)	-70 to 500°C (-94 to 932°F)	PD, PF	Ceramic	AWG 27, solid glass insulated nickel	▼ S102410
	Ø .188" x .90" (Ø 4.8 x 22.9 mm)	-50 to 150°C (-58 to 302°F)	PD, PF	Silicone rubber	AWG 24, silicone rubber insulated	▼ S102406
	Ø .188" x 1.25" (Ø 4.8 x 31.8 mm)	-50 to 230°C (-58 to 446°F)	PD, PF	PTFE	AWG 24, PTFE with PTFE jacket	▼ S102405
	Ø .188" x 1.25" (Ø 4.8 x 31.8 mm)	-50 to 260°C (-58 to 500°F)	PD, PF	Aluminum	AWG 22, PTFE insulated	▼ S102407
	Ø .188" x 2.38" (Ø 4.8 x 60.5 mm)	-70 to 550°C (-94 to 1022°F)	PD, PF	Stainless steel	AWG 22, glass braid insulated	▼ S102408

MINIATURE SENSORS

## Overview

Economy sensors are designed to be a component of your final assembly. With insulated leads preattached and strain relieved, final construction is easy and reliable.

- Insulated leads of variable length, installed and strain relieved
- Wide temperature range
- Configurations to fit most applications
- Standard 100 Ω platinum, 1000 Ω platinum and 120 Ω nickel elements

## Specifications

**Insulation resistance:** 10 megohms minimum at 100 VDC, leads to case.

**Vibration:** Withstands 10 to 2000 Hz at 20 G's minimum per MIL-STD-202. Method 204, test condition D.

Element specifications*	Code
Platinum (0.00385 TCR) 100 Ω ±0.12% at 0°C (EN60751, Class B)	▼ PD
Platinum (0.00385 TCR) 1000 Ω ±0.12% at 0°C	▼ PF

\* See descriptions for element options on each model.

## Specification and order options

S102408	Model number from table
PD	Element code from table
3	<b>Number of leads:</b> ▼ 2 leads (not recommended for PD models) or ▼ 3 leads (only option for S102410PD)
G	<b>Leadwire covering:</b> ▼ E = Enamel (S102404) ▼ G = Glass (S102408 and S102410) ▼ R = Silicone rubber (S102406) ▼ T = PTFE (S102405, S102407, S102409, S102737)
40	<b>Leadwire length in inches:</b> 40" (1000 mm) standard ▼ : 40, 120
S102408PD3G40 = Sample part number	



**STOCKED PARTS AVAILABLE**

▼ = STANDARD OPTIONS  
Specifications subject to change



# Installation and Accessories

## Case style A

Install case style A sensor just below the babbitt layer, then puddle the babbitt metal over the sensor tip and smooth. Read [Engineering Instruction #164](#) and [Engineering Instruction #167](#) for complete details.

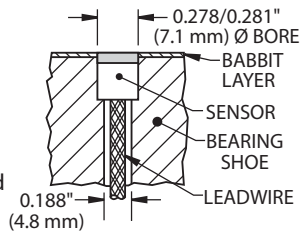

## Case style B

The “top hat” flange shape allows spring loading with the AC171 spring and AC172 or AC915 retaining ring (order separately). Choose the economical AC172 style for lowest cost. The AC915 style allows removal and reinstallation. Slide the spring and ring over the leads, insert the sensor tip into a milled hole, and push down on the retaining ring to compress the spring and secure the sensor. Read [Engineering Instruction #180](#) and [Engineering Instruction #181](#).

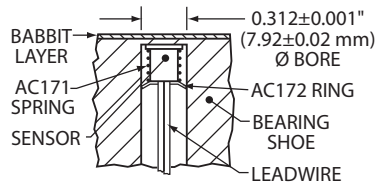

## Case styles C and D

Pot with epoxy inside small bearing shoes. Locate near the babbitt face for best readings. Read [Engineering Instruction #184](#).

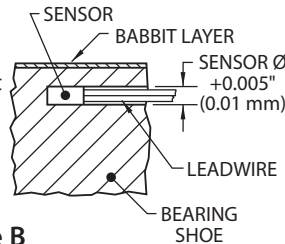

## AC171 spring for case style B

Stainless steel. Outside diameter 0.240" (6.1 mm). Compressed length 0.22" (5.6 mm). To be used in conjunction with AC172 or AC915 for spring loading case style B

## Feedthroughs

Feedthroughs provide an oil tight seal where a cable exits a machine housing. The stainless steel tube is epoxy filled and each wire is sealed to the individual conductor. This prevents wicking of oil inside the wires as well as leakage around the wire insulation. Pressure rating to 25 psi (1.7 bar). See page 3-12 for more information.

## AC172 and AC915 retaining ring for case style B

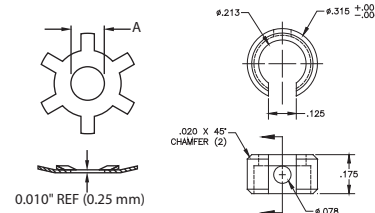

Model	"A" diameter	Hole I.D.
AC172	sized to fit leadwires	0.312" (7.92 mm)
AC172-3	0.175" (4.45 mm)	0.375" (9.53 mm)
AC915-1	0.213" (5.4 mm)	0.312" (7.92 mm)

## AC190 terminal block

Two tin-plated brass terminals. PTFE body. Meets MIL-T-17600. For instructions, read [Installation Instruction #107](#).

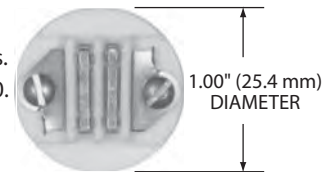

## AC191 terminal block

Two tin-plated brass terminals. PTFE body. Meets MIL-T-17600. Read [Installation Instruction #121](#) for instructions.



## AC192 terminal block

Three tin-plated brass terminals. Glass-filled PTFE body.

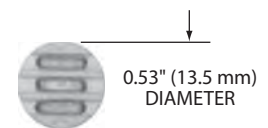

## AC195 terminal block

Same as AC192 except polyamide-imide body for radiation resistance to 10<sup>9</sup> rads.

## AC197 terminal block

Three tin-plated brass terminals. Glass-filled PTFE body.



## AC196 terminal block

Same as AC197 except polyamide-imide body for radiation resistance to 10<sup>9</sup> rads.

▼ = **STANDARD OPTIONS**  
Specifications subject to change



## ► SECTION 7: STATOR WINDING SENSORS

- Install between stator windings for continuous protection of motors and generators
- Increased safety sensors for use in hazardous areas
- Single and dual elements offer high reliability
- Sensor dimensions to fit any machine
- Class F or Class H

Increased safety RTDs .....	7-2 to 7-3
Single element RTDs .....	7-4 to 7-5
Dual element RTDs.....	7-6
Corona resistant RTD.....	7-7
Machinery protection products .....	7-8

# Increased Safety Stator Winding Temp. Sensors

ATEX  II 2 G Ex e IIC Gb

ATEX  II 1 G Ex ia IIC Ga

IECEX Ex e IIC Gb

IECEX Ex ia IIC Ga

CSA Ex e IIC Gb



## Overview

Insert these thin, laminated RTDs in winding slots to detect high temperatures before insulation damage occurs. RTD temperature sensors continuously monitor conditions and provide the long term trend data that is necessary for making adjustments before unexpected alarms occur. These models are designed for use in hazardous areas, where there may be a presence of flammable gas under normal operating conditions. Strict construction guidelines prevent arcing. These RTDs are certified as “increased safety” and “intrinsic safety” devices.

- Pt100, Ni100, or U.S. curves
- EC-Type Examination Certificate KEMA 03ATEX2240 U
- Complies with European standards for electrical apparatus for potentially explosive atmospheres: ATEX Directive 94/9/EC and International IEC certification schemes for explosive atmospheres.

## Specifications

**Temperature limit:** -50 to 180°C (-58 to 356°F), class H

**Body material:** High temperature epoxy glass.

**Leadwires:** 2, 3, or 4 leads, stranded copper, AWG #22 (0.35 mm<sup>2</sup>, with TFE or polyimide insulation).

**Dielectric strength:** 3,200 VRMS at 60 Hz, 1 mA maximum leakage current, tested momentarily (1–5 seconds), between the leads and external flat body surface.

## Specification and order options

S100050 PD	Model number from table on next page
60	<b>RTD length in .1" increments:</b> Example: 79 = 7.9" (200 mm) Minimum length = 20 (2.0" [51 mm]) Maximum length = 232 (23.2" [590 mm]) ▼: 60, 110, 200
T	<b>Lead insulation:</b> ▼ T = TFE
236	<b>RTD width in .001" increments:</b> Example: 394 = .394" (10 mm) Minimum width = .219" (5.6 mm) for 2 or 3 leads; = .285" (7.25 mm) for 4 leads Maximum width = .956" (25.4 mm) ▼: 236, 315
Z	<b>Number of leads:</b> Y = 2 leads ▼ Z = 3 leads ▼ X = 4 leads
118	<b>Lead length in inches</b> ▼: 118, 237
F	<b>Lead configuration:</b> ▼ T = Twisted leads ▼ F = Flat leads
N	<b>Lead covering:</b> ▼ N = No jacket ▼ S = FEP jacket overall (available only with twisted lead configuration option "T")
S100050PD60T236Z118FN = Sample part number	

▼ = **STANDARD OPTIONS**  
 Specifications subject to change

## Wire-wound or thin-film RTD element

Wire-wound RTDs, embedded in stator slots, are the most common method for measuring winding temperature in large motors. The wire-wound element extends through most of the body length and measures the average temperature of the winding.

Thin-film RTDs are identical, except for the size of the sensing element. Because the thin-film element is small, approximately 0.08" x 0.09" (2.0 mm x 2.3 mm), it senses the temperature in only one small spot of the winding. Thin-film elements are best suited for shorter length stator sensors.

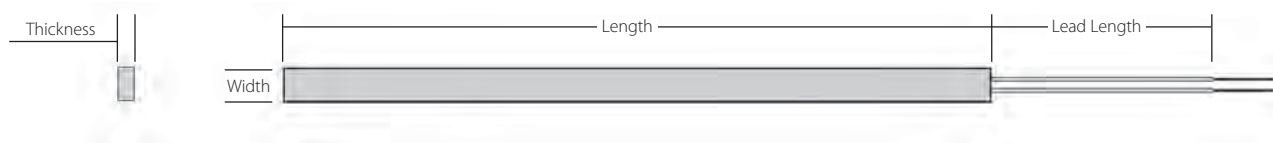

### Wire-wound RTD elements

Thickness	Platinum (0.00385 TCR) 100Ω ±0.12 at 0°C Meets IEC 751, Class B	Platinum (0.00385 TCR) 100Ω ±0.5 at 0°C	Nickel (0.00618 TCR) 100Ω ±0.2 at 0 C Meets DIN 43760	Platinum (0.00392 TCR) 100Ω ±0.5 at 0°C
0.079" [2.0 mm]	▼ S100050PD	S100050PE	S100050NB	▼ S100050PA
0.098" [2.5 mm]	S100051PD	S100051PE	S100051NB	S100051PA
0.118" [3.0 mm]	S100052PD	S100052PE	S100052NB	S100052PA
0.138" [3.5 mm]	S100053PD	S100053PE	S100053NB	S100053PA
0.157" [4.0 mm]	S100054PD	S100054PE	S100054NB	S100054PA

### Thin-film RTD elements

Thickness	Platinum (0.00385 TCR) 100Ω ±0.12 at 0°C Meets IEC 751, Class B	Platinum (0.00385 TCR) 100Ω ±0.5 at 0°C	Nickel (0.00618 TCR) 100Ω ±0.2 at 0 C Meets DIN 43760	Platinum (0.00392 TCR) 100Ω ±0.5 at 0°C
0.079" [2.0 mm]	S200050PD	S200050PE	S200050NB	S200050PA
0.098" [2.5 mm]	S200051PD	S200051PE	S200051NB	S200051PA
0.118" [3.0 mm]	S200052PD	S200052PE	S200052NB	S200052PA
0.138" [3.5 mm]	S200053PD	S200053PE	S200053NB	S200053PA
0.157" [4.0 mm]	S200054PD	S200054PE	S200054NB	S200054PA

▼ = **STANDARD OPTIONS**  
Specifications subject to change

# Single Element Stator Winding RTDs



## Overview

Flat, laminated “stick” RTDs fit in slots between stator windings to monitor temperature rise and prevent overheating. The National Electrical Manufacturers Association (NEMA) recognizes embedded detectors as a standard protection for motor and generator insulation. Unlike on-off devices, RTDs provide continuous sensing for earlier warning without unnecessary tripouts.

The sensing elements of stator RTDs extend through most of the body length to provide an average temperature reading. This eliminates the danger of a point-type sensor missing a localized hot spot. Six sensors are recommended for each motor, two per phase. Locate sensors near the hottest point of the windings for best performance.

Minco stator RTDs meet the specifications of ANSI C50.10-1990, general requirements for synchronous motors.

## Custom designs

Minco designs and builds custom models for many applications. We offer unmatched capabilities because we control all steps of the production from element to finished product. Examples of special options include:

- Thermocouple elements
- Thermistor elements (PTC or NTC)
- Dual sensors with different elements (for example, one copper and one platinum element)
- Ex rated sensors for equipment in hazardous areas. See page 7-2 for more information.
- Electrically conductive coating
- Special leadwire or cable

## Specifications

### Temperature limit:

Class F: 155°C (311°F)  
Class H: 180°C (356°F).

### Body material:

Class F: Epoxy glass  
Class H: High temperature epoxy glass.

### Standard sizes (others available):

Thickness inches (mm)	0.030 (.76)	0.050 (1.3)	0.078 (2.0)	0.125 (3.2)
Length inches (mm)	6.0 (152)	10.0 (254)	11.0 (279)	12.0 (305)
Standard body width inches (mm)	0.219 (5.6) 0.344 (8.7) 0.563 (14) 1.000 (25)	0.260 (6.6) 0.406 (10) 0.656 (17)	0.305 (7.7) 0.455 (12) 0.750 (19)	0.315 (8.0) 0.500 (13) 0.875 (22)

Note: Order any width from 0.219" (5.6mm) to 2.500" (64mm)

**Leadwires:** 2, 3, or 4, stranded copper with PTFE or polyimide insulation. Other leadwire coverings available.

- 0.125" thick: AWG 18.
- 0.078" thick: AWG 22.
- 0.050" thick: AWG 26.
- 0.030" thick: AWG 30 (no lead bulge);  
AWG 18 (0.110" lead bulge);  
Cable (0.110" lead bulge).

**Dielectric strength:** 3200 VRMS at 60 Hz, tested between the leads and external flat body surface for 1 to 5 seconds.

▼ = STANDARD OPTIONS  
Specifications subject to change



## Class H (180°C) RTDs

Element	Model thickness:			
	0.030" (.76mm)	0.050" (1.3mm)	0.078" (2.0mm)	0.125" (3.2mm)
Platinum (0.00392 TCR) 100 Ω ±0.5% at 0°C	▼ S1420PA <sup>1</sup>	▼ S7401PA	▼ S13PA	S8016PA
Platinum (0.00385 TCR) 100 Ω ±0.12% at 0°C (Meets EN60751, Class B)	▼ S8010PD <sup>1</sup> ▼ S100305PD <sup>2</sup> S100415PD <sup>3</sup>	▼ S8014PD	▼ S11016PD	S8016PD
Platinum (0.00385 TCR) 100 Ω ±0.5% at 0°C	S8010PE <sup>1</sup>	S8014PE	S8012PE	S8016PE
Copper (0.00427 TCR) 10 Ω ±0.2% at 25°C	▼ S1220CA <sup>1</sup>	▼ S7401CA	▼ S18CA	S8016CA
Nickel (0.00672 TCR) 120 Ω ±0.5% at 0°C	▼ S1240NA <sup>1</sup>	▼ S7401NA	▼ S15NA	S8016NA

**Notes:**

<sup>1</sup> Leadwires: AWG 30; lead bulge: 0.045" thick, extending into the body a maximum of 0.62".

<sup>2</sup> Leadwires: AWG 18; lead bulge: 0.110" thick, extending into the body a maximum of 1.75".

<sup>3</sup> Leadwires: AWG 30 with PTFE jacket overall; lead bulge: 0.110" thick, extending into the body a maximum of 1.75".

## Specification and order options

S13PA	Model number from table
110	<b>Body length:</b> Specify in 0.1" increments (Example: 110 = 11.0 inches) ▼ : 20, 60, 110
T	<b>Leadwire insulation:</b> ▼ T = PTFE
344	<b>Body width:</b> Specify in 0.001" increments (Example: 344 = 0.344 inches) Minimum body widths: S8015, 2 or 3-lead: 320 S8015, 4-lead: 420 S8016, 2 or 3-lead: 320 S8016, 4-lead: 420 S100305: 310 S100415: 310 All other 2 or 3-lead models: 219 All other 4-lead models: 320 ▼ : 219, 260, 305, 344
Z	<b>Number of leads:</b> Y = 2 leads (PA, PE, NA only) ▼ Z = 3 leads X = 4 leads
36	<b>Lead length in inches</b> ▼ : 36, 120, 240
S13PA110T344Z36 = Sample part number	

▼ = **STANDARD OPTIONS**  
Specifications subject to change



# Dual Element Stator Winding RTDs



## Overview

Dual element stator winding RTDs provide extra protection for motors and generators. The second element can be a back up in case of damage, or use one element for input to a temperature display at the machine and the other for control room monitoring.

Standard models are available with thickness options of 0.030" to 0.125", with sensing elements to match most instrumentation.

## Custom designs

Minco designs and builds custom models for many applications. We offer unmatched capabilities because we control all steps of the production from element to finished product. Examples of special options include:

- Thermocouple elements
- Thermistor elements (PTC or NTC)
- Dual sensors with different elements (for example, one copper and one platinum element)
- Ex rated sensors for equipment in hazardous areas. See page 7-2 for more information.
- Electrically conductive coating
- Special leadwire or cable

## Specifications

**Temperature limit:** 180°C (356°F), class H.

**Body material:** High temperature epoxy glass.

### Standard sizes:

Thickness inches (mm)	0.030 (.76mm)	0.050 (1.3mm)	0.078 (2.0mm)	0.125 (3.2mm)
Length inches (mm)	2.0 to 35.0" (51 to 899 mm)		2.0 to 48.0" (51 to 1219.2 mm)	
Body width inches (mm)	0.425 to 1.065 (10.8 to 27.0 mm)		0.425 to 2.500 (10.8 to 63.5 mm)	

**Leadwires:** 2 or 3 (per element) stranded copper with PTFE or polyimide insulation. Other leadwire coverings available.

- 0.125" thick: AWG 18.
- 0.078" thick: AWG 22.
- 0.050" thick: AWG 26.
- 0.030" thick: AWG 30.

**Dielectric strength:** 3200 VRMS at 60 Hz, tested between the leads and external flat body surface for 1 to 5 seconds.

## Class H (180°C) RTDs

Element	Model for thickness:			
	0.030" *	0.050"	0.078"	0.125"
Platinum (0.00392 TCR) 100 Ω ±0.5% at 0°C	▼S9030PAPA	▼S9050PAPA	▼S9078PAPA	S9125PAPA
Platinum (0.00385 TCR) 100 Ω ±0.12% at 0°C (Meets EN60751, Class B)	▼S9030PDPD	▼S9050PDPD	▼S9078PDPD	S9125PDPD
Platinum (0.00385 TCR) 100 Ω ±0.5% at 0°C	S9030PEPE	S9050PEPE	S9078PEPE	S9125PEPE
Copper (0.00427 TCR) 10 Ω ±0.2% at 25°C	S9030CACA	S9050CACA	S9078CACA	S9125CACA
Nickel (0.00672 TCR) 120 Ω ±0.5% at 0°C	S9030NANA	S9050NANA	S9078NANA	S9125NANA

\*Model has a lead bulge 0.045" (0.11mm) thick, extending into the body a maximum of 0.62" (1.6mm).

## Specification and order options

S9078PAPA	Model number from table
110	<b>Body length:</b> Specify in 0.1" increments (Ex: 110 = 11.0") ▼: 60, 110
T	<b>Leadwire insulation:</b> ▼T = PTFE
425	<b>Body width:</b> ▼425 Specify in 0.001" increments (Ex: 425= 0.425")
Z	<b>Number of leads per element:</b> Y = 2 leads (PA, PE, NA only) ▼Z = 3 leads
36	<b>Lead length in inches</b> ▼: 36, 240
S9078PAPA110T425Z36 = Sample part number	

▼ = STANDARD OPTIONS  
Specifications subject to change

# Corona Resistant Stator RTD

## Overview

Motor manufacturers that use variable speed drives for flexibility and high performance can experience corona related problems. PWM inverters can create high voltage spikes exceeding 1600 volts. Minco has answered the call with a corona resistant RTD. This RTD is specifically designed for the latest generation of variable frequency drives for AC motors. Minco uses special materials and manufacturing techniques to create an RTD that is virtually corona-proof, eliminating the need for expensive reactors or filters for the sensors.\*\*

- Designed for AC motors with variable frequency drives (VFD)
- Proprietary design\* resists detrimental effects of corona
- Protect expensive motors with an inexpensive overtemperature warning system
- Tested to 10,000 VAC without failure
- Widths from 0.305" to 1.25"
- Lengths from 7" to 30"

## Specifications - Model S8025

**Temperature:** 180°C (356°F); Class H.

**Thickness:** 0.030" (0.075" max. thickness over lead bulge).

**Length:** 7" to 30".

**Width:** 0.305" to 1.25" (2 and 3 lead models); 0.344" to 1.25" (4 lead models).

**Leadwires:** 2, 3, or 4 AWG #22, stranded copper; PTFE or polyimide insulation.

**Element:** Platinum; 100 Ω ±0.5% at 0°C; 0.00392 TCR.

**Body material:** Polyimide, corona resistant.

**Dielectric strength:** Body: 8000 VRMS at 60 Hz; Leads and leadwire exit (0.5" into body): 5000 VRMS at 60 Hz.

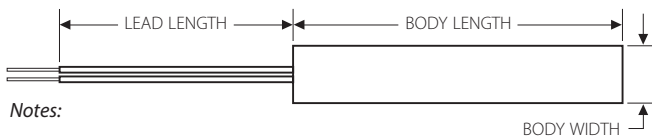

Notes:

\* Patent pending

\*\* Reducing the effects of corona on motor windings is the responsibility of the motor manufacturer

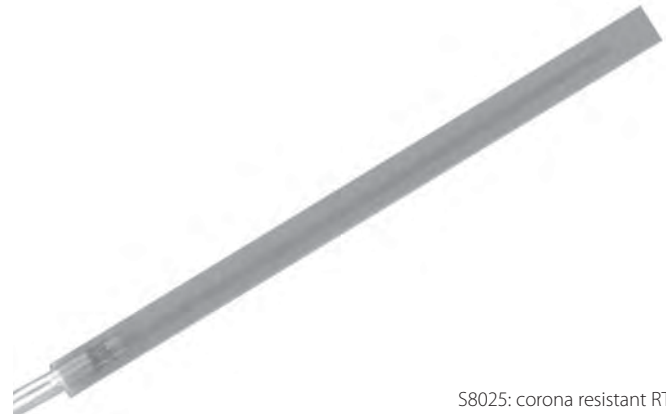

S8025: corona resistant RTD

## Specification and order options

S8025	Model Number
PA	<b>Sensing element</b> PA = Platinum, 100 Ω ±0.5%, 0.00392
120	<b>Body length:</b> Specify in 0.1" increments (Example: 120 = 12.0") Minimum = 70; maximum = 300
T	<b>Leadwire insulation:</b> T = PTFE K = Polyimide
500	<b>Body width:</b> Specify in 0.001" increments (Example: 500 = 0.500") Minimum = 305 (2 and 3 lead models) Minimum = 344 (4 lead models) Maximum = 1250
Z	<b>Number of leads per element:</b> Y = 2 leads Z = 3 leads X = 4 leads
36	<b>Lead length in inches</b>
F	<b>Leadwire configuration</b> F = Flat T = Twisted
S8025PA120T500Z36F = Sample part number	

STATOR RTDs

▼ = STANDARD OPTIONS  
Specifications subject to change



# Machinery Protection Products

## CT224 12-channel temperature alarm/monitor

The CT224 consists of a 12-Channel Temperature Monitor and MincoSoft™ CT224 Software. It is the next generation in temperature monitoring equipment from Minco designed to meet the needs of electric machinery protection. The 12-channel scanning capability, standard RS485/RS232 interface and Windows-compatible software utility for system configuration and data logging provide overtemperature and undertemperature protection and critical feedback to safeguard expensive machinery.

- UL and cUL recognized to help meet regulatory compliance
- Mix and match sensor input types for freedom to adapt to pre-installed bearing and apparatus sensors
- Ability to monitor 12 inputs allows you to monitor stator sensors from two motors

See page 4-25 for details.



## End turn RTD

Model S3238 Thermal-Ribbon is designed to sense stator temperatures in motors and generators. With an alternative installation method to the “stick-type” sensors in this section, S3238 is used on the end turns of stator windings and provides an easy way to add overtemperature protection when the stator is not being rewound.

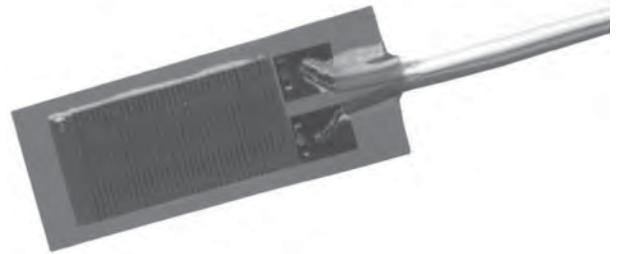

See page 9-5 for details.

## CT15 temperature alarm

- Alarm shuts down motor on over-temperature to prevent catastrophic failure
- Monitors single 100  $\Omega$  platinum RTD (PD or PE)
- 1 or 2 relays with independent trip points for warning and shutdown
- Microprocessor-based
- Front panel programmable with four security levels
- 100 to 240 VAC supply power
- Compact DIN case with water resistant front panel



See pages 4-33 for details.

## Anti-condensation space heaters

- Flexible silicone rubber insulation
- Mount on windings or housings to prevent moisture buildup
- 2.5 to 10 watts per square inch at 120 or 240 volts
- Variety of sizes to 60" (1.5 m)
- UL component recognition
- Available from stock



Go to [www.minco.com](http://www.minco.com) for more information.

*Specifications subject to change*



## ► SECTION 8: HVAC SENSORS

- Complete range of sensors/transmitter assemblies made for easy installation, high reliability, and compatibility with almost any Building Automation System
- Accurate and stable sensing ensures maximum energy efficiency
- Optional matched system calibration of transmitters and sensors offer increased accuracy
- RTDs, thermistors and humidity sensing for a variety of applications in critical environments

Chill-Out™ combination sensor.....	8-2 to 8-3
Averaging temperature sensors.....	8-4
Duct and outside air temperature sensors.....	8-5
Room air temperature sensors.....	8-6
Flexible Thermal-Ribbon™ pipe sensors.....	8-7
Humidity sensor/transmitter assembly.....	8-8 to 8-9
Hazardous area humidity assembly.....	8-10 to 8-11
Intrinsically safe humidity assembly.....	8-12 to 8-13
Thermal Vial™ temperature sensing system.....	8-14 to 8-15
Refrigeration and freezer temperature system.....	8-16
Fluid immersion temperature sensors.....	8-17
Elements and probes.....	8-18
Temptran 4 to 20 mA transmitters.....	8-19

# Chill-Out™ Combination Sensor

## Overview

- Two sensors in one easily installed package: a solid state low temperature cut-out ("Freeze Stat") and an averaging resistance temperature sensor.
- Digital alarm signal to RTU, PLC or an electronic control; 24VAC-powered.
- Solid state design and rugged 3/8" diameter tubing eliminate concerns of gas leaks or kinking the capillary during installation.
- Mount in any direction — horizontal installation is not required.
- Easily formed aluminum or ultra flexible plenum-rated PVC coated galvanized steel armor sensor case.
- Relay and control circuitry self contained in rugged housing. Mounts on either side of enclosure with a locknut (included).
- Failure detection feature — relay changes state if power is lost
- 4 to 20 mA temperature loop output available with optional Temptran™ (ordered separately — see Section 4 for more information)

## Specifications

**Switching temperature:** 38°F factory pre-set, user adjustable from 30°F to 44°F.

**Accuracy:** ±0.9°F (±0.5°C) typical.

**Power requirement:** 24V AC or DC.

**Relay contact:** User specified

Standard relay, SPDT (2" x 4" utility box)  
 0.3 A at 125 VAC, Max. Voltage 125 VAC, or  
 1A at 30 VDC, Max. Voltage 110 VDC

Optional power relay, DPST (4" x 4" utility box)

- 25 A at 277 VAC
- 25 A at 120 VAC
- 1 HP at 120 VAC
- 2 HP at 277 VAC

**Sensor case length:** 10 feet standard, lengths up to 50 feet available by special order.

**Connection:** AWG 18 leadwires.

Chill-Out Sensor installation example

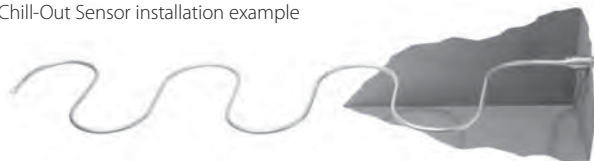

Bendable Aluminum

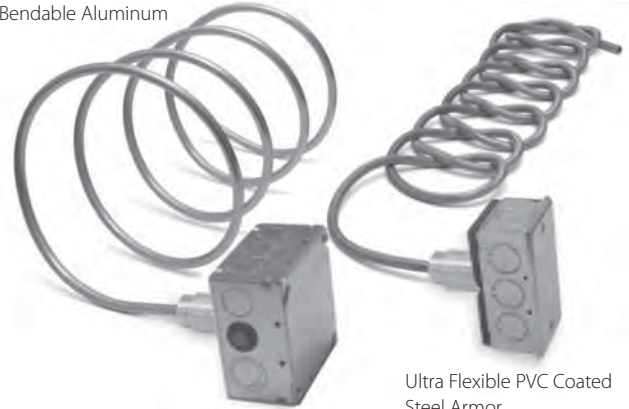

Ultra Flexible PVC Coated Steel Armor

## Specification and order options

▼AS103759	Model number
PF	Element Type: PF = 1000 Ω RTD (0.00385 Platinum)
38	Switching Temperature: ▼38°F Specify 30 to 44°F
E	Relay reset option: N = Non-latching (auto reset) ▼L = Latching (manual reset) ▼E = Latching (panel mounted reset) Note: option 'E' requires enclosure 'L'
10	Case length: 10 feet ▼: 10, 24, 50
A	Case type: ▼A = Aluminum ▼B = PVC
1	Relay Rating: ▼1 = 0.3A ▼2 = 25A, VAC powered controller/coil 3 = 25A, VDC powered controller/coil Note: option 2 or 3 requires enclosure 'L'
L	Enclosure: N = No enclosure S = Standard utility box (2" x 4") ▼L = Large utility box (4" x 4") W = Weatherproof utility box (2" x 4")
AS103759PF38E10A1L = Sample part number	

## Order Replacement Relays

Model number	External Relay
AC103779	25A 24VAC Coil
AC103780	25A 24VDC Coil

▼ = STANDARD OPTIONS  
 Specifications subject to change

### Chill-Out Sensor Interface

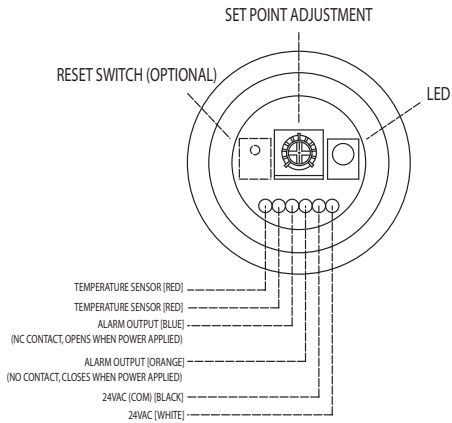

### Setpoint Adjustment

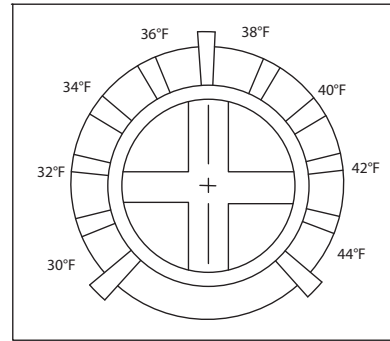

### Standard and Large Utility Boxes

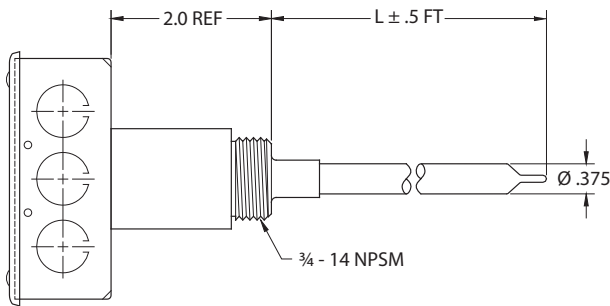

### No Enclosure

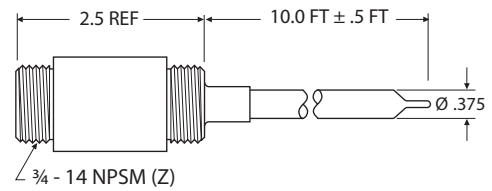

### Weatherproof Utility Box

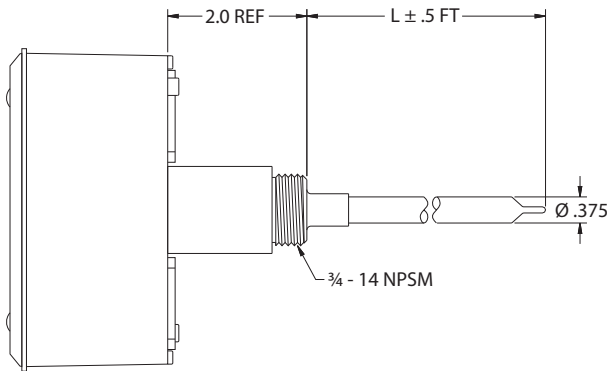

### Typical Installation with Relay

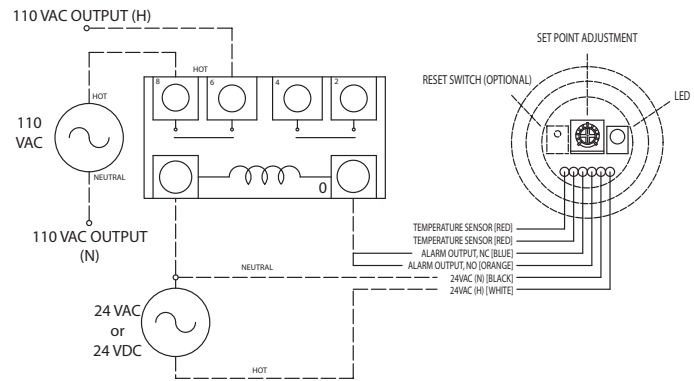

▼ = **STANDARD OPTIONS**  
Specifications subject to change

# Averaging Temperature Sensors

## Overview

Sense temperature of air streams in ducts and plenums. Sensors include a junction box with gasket to prevent leakage and vibration noise.

These sensors have a continuous element to sense true average temperature along their entire length. They provide accurate composite readings in locations where air may be stratified into hot and cold layers.

Rigid averaging sensors have a brass case. Bendable models have aluminum sheaths (copper on special order), formable to a radius of 4". Bendable sensors can criss-cross ducts to average temperatures in two dimensions.

See page 4-2 for optional 4 to 20 mA temperature transmitters.

## Specifications

### Temperature range:

Probe: -45.5 to 135°C (-50 to 275°F).

Gasket: 100°C (212°F) max.

Leadwires: AWG 22, PTFE insulated, 8" (200 mm) long.

Moisture resistance: Meet MIL-STD-202, Method 104, Test Condition B.

### Special options:

- Lengths to 100 feet(30 m)
- Weatherproof connection box
- Sensor only, no box
- Thermistor averaging sensors

## Model numbers

RTDs (Tolerance: ±0.25% at 70°F)	TCR Ω/Ω/°C	Rigid averaging sensors	Bendable averaging sensors
*Platinum 100 Ω at 0°C	0.00391	S423PB	S447PB
*Platinum 100 Ω at 0°C	0.00385	▼ S456PE	▼ S457PE
*Platinum 1000 Ω at 0°C	0.00385	▼ S493PF	▼ S475PF
*Platinum 1000 Ω at 0°C	0.00375	S492PW	▼ S488PW
Nickel-iron 1000 Ω at 70°F	0.00527	S421FB	S445FB
Nickel-iron 2000 Ω at 70°F	0.00527	S422FC	S446FC
*HW 3000 Ω at -30.2°C	0.00262	S20080PX	▼ S15215PX

\*These averaging sensors use a proprietary sensing element that closely matches the platinum curve over the specified range.



**STOCKED PARTS AVAILABLE**

▼ = **STANDARD OPTIONS**

Specifications subject to change

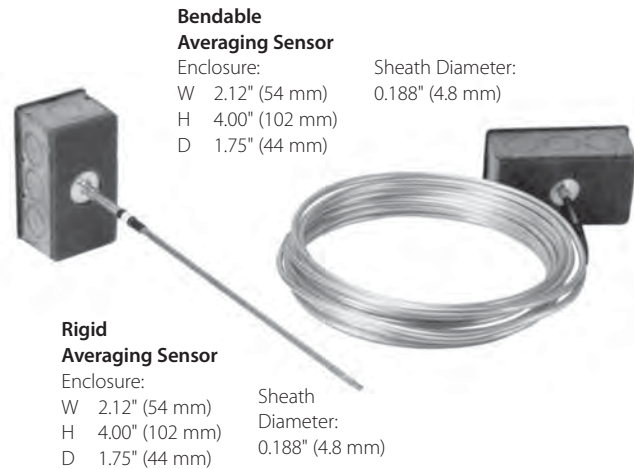

### Bendable Averaging Sensor

Enclosure:  
W 2.12" (54 mm)  
H 4.00" (102 mm)  
D 1.75" (44 mm)

Sheath Diameter:  
0.188" (4.8 mm)

### Rigid Averaging Sensor

Enclosure:  
W 2.12" (54 mm)  
H 4.00" (102 mm)  
D 1.75" (44 mm)

Sheath Diameter:  
0.188" (4.8 mm)

## Specification and order options:

### Rigid averaging sensors

S456PE	Model number from table
Y	Number of leads: ▼ Y = 2 leads Z = 3 leads
12	Insertion depth in inches: 1 inch = 25.4 mm ▼ : 12, 24, 48
S456PEY12 = Sample part number	

### Bendable averaging sensors

S457PE	Model number from table
Z	Number of leads: ▼ Y = 2 leads ▼ Z = 3 leads
24	Insertion length in feet: 1 foot = 0.3 m ▼ : 12, 24, 50, 100
S457PEZ24 = Sample part number	

## To order with transmitter, add

TT111	Transmitter Models TT111: Fixed Range (2 leads) TT211: Fixed Range (2 leads) TT321: Fixed Range (3 leads) <i>Contact for other transmitter options.</i>
A	Temperature Range Code: A = 20°F to 120°F (-6.7°C to 48.9°C) <i>Contact for complete list of available temp. codes.</i>
1	Calibration: 1 = Nominal Calibration 2 = Match Calibrated, 0.75% Total System Accuracy <i>Contact for other calibration options.</i>
TT111A1 = Sample part number addition	



# Duct and Outside Air Temperature Sensors

## Overview

Sense temperature of air streams in ducts and plenums. Sensors include a junction box with gasket to prevent leakage and vibration noise.

These point-sensing thermometers feature a fast-responding aluminum sensing tip.

Custom options include a weatherproof connection box and an all stainless steel probe.

Outside air sensors are designed to mount on conduit outside your building. They include an elbow type enclosure and sun shield.

See page 4-2 for optional 4 to 20 mA temperature transmitters.

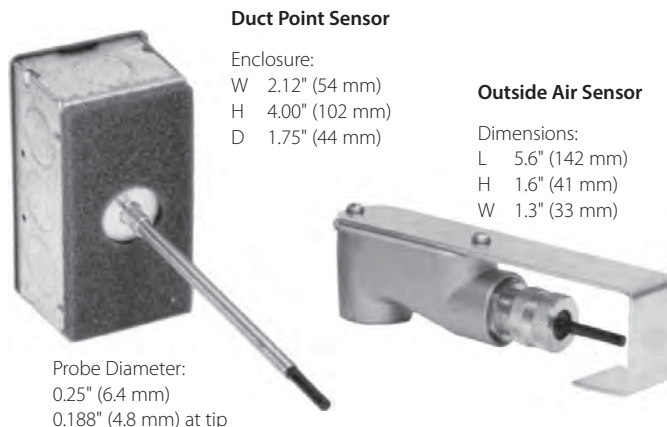

## Specifications

### Temperature range:

Probe: -45.5 to 135°C (-50 to 275°F).

Gasket: 100°C (212°F) max.

### Leadwires:

AWG 22, PTFE insulated,  
4" (100 mm) long.

### Moisture resistance:

Point sensors meet MIL-STD-202, Method 104, Test Condition B

## Special options

- Weatherproof connection box
- All stainless steel probe



**STOCKED PARTS AVAILABLE**

## Model numbers

Element	TCR $\Omega / \Omega / ^\circ\text{C}$	Duct point sensors	Outside air sensors
RTDs			
Platinum 100 $\Omega \pm 0.1\%$ at 0°C	0.00391	▼S408PB	▼S414PB
Platinum 100 $\Omega \pm 0.1\%$ at 0°C (Meets EN60751, Class B)	0.00385	▼S450PD	▼S454PD
Platinum 1000 $\Omega \pm 0.1\%$ at 0°C	0.00385	▼S451PF	S455PF
Platinum 1000 $\Omega \pm 0.1\%$ at 0°C	0.00375	▼S484PW	S486PW
Nickel-iron 1000 $\Omega \pm 0.12\%$ at 70°F	0.00527	S406FB	S412FB
Nickel-iron 2000 $\Omega \pm 0.12\%$ at 70°F	0.00527	S407FC	S413FC
HW 3000 $\Omega$ at -30.2°C	0.00262	S100060PX	S100062PX
Thermistors <small>R251/4R125</small>			
Thermistor 2,252 $\Omega \pm 1\%$ at 25°C	29.2	TS430TA	TS428TA
Thermistor 10,000 $\Omega \pm 1\%$ at 25°C	23.5	TS431TB	TS429TB

Specifications subject to change

## Specification and order options:

### Duct point sensors

S450PD	Model number from table
Y	Number of leads: ▼ Y = 2 leads Z = 3 leads (RTD only)
12	Insertion depth in inches: 1 inch = 25.4 mm ▼ : 6, 12, 18" Minimum: 3"
S450PDY12 = Sample part number	

### Outside air sensors

S414PB	Model number from table
Z	Number of leads: ▼ Y = 2 leads ▼ Z = 3 leads (RTD only)
S414PBZ = Sample part number	

## To order with transmitter, add

TT111	Transmitter Models TT111: Fixed Range (2 leads) TT211: Fixed Range (2 leads) TT321: Fixed Range (3 leads) <i>Contact for other transmitter options.</i>
A	Temperature Range Code: A = 20°F to 120°F (-6.7°C to 48.9°C) <i>Contact for complete list of available temp. codes.</i>
1	Calibration: 1 = Nominal Calibration 2 = Match Calibrated, 0.75% Total System Accuracy 3 = Match Calibrated, 0.5% Total System Accuracy 4 = Match Calibrated, 0.2% or 1°C Total System Accuracy <i>Contact for other calibration options.</i>
TT111A1 = Sample part number addition	

# Room Air Temperature Sensors

## Compact Wall-mount

Dimensions:

W 3.12" (79 mm)  
H 2.09" (54 mm)  
D 1.80" (46 mm)



## Full Size Wall-mount

Dimensions:

W 2.75" (70 mm)  
H 4.50" (114 mm)  
D 1.56" (40 mm)



## Explosionproof Wall-mount

Dimensions:

W 1.60" (41 mm)  
H 5.55" (141 mm)  
D 2.05" (52 mm)



## Flush Wall-mount

Dimensions:

W 2.75" (70 mm)  
H 4.50" (114 mm)  
D 0.18" (5 mm)



## Overview

Minco's room air sensors are available with a variety of enclosures that meet most standard and explosionproof HVAC/R installations. The sensors can be match calibrated with a Minco Tempran™ (temperature transmitter) for increased accuracy and reliability.

Room air sensors are designed for wall mounting. Choose from two plastic enclosure styles with brushed aluminum faceplates or a flushmount stainless steel model.

The full-size enclosure and flushmount fit over standard junction boxes. The full size enclosure has optional knockouts for Wiremold raceway surface wiring. Just remove knockouts with pliers. This enclosure may also include a 4-20 mA temperature transmitter; specify model AS200655.

The compact room air sensor mounts directly on drywall.

The explosionproof sensor housing is UL listed and CSA approved for Class I, Groups C and D; Class II, Groups E, F, and G; and Class III. Download Application Aid #19 for more hazardous area information and the various standards and agencies (including FM, CSA, CENELEC and ATEX) at [www.minco.com](http://www.minco.com).

## Specifications

### Temperature range:

-45.5 to 100°C (-50 to 212°F)

### Temperature range (with TT115 transmitter):

Zero: -40 to 10°C (-40 to 50°F)

Span: 25 to 100°C (45 to 180°F)

Max upper temperature: 85°C (185°F)

### Leadwires:

Full size and compact: AWG 22,

PTFE insulated, 4" (100 mm) long.

Explosionproof and flush mount: AWG 26,

PTFE insulated, 6" (150 mm)

inside cover.

**Moisture resistance:** Meets MIL-STD-202, Method 104, Test Condition B.

**Transmitters:** Full size sensors with 2 leads can use Tempran™ transmitter model TT115 installed within the sensor enclosure. A variety of transmitters are available for all other sensor models. Transmitters must be installed in a separate enclosure from the sensor.

## Specification and order options:

### Compact and full size

S472PB	Model number from table
Y	Number of leads: ▼ Y = 2 leads      Z = 3 leads
4	Lead length in inches: ▼: 4
K0	Knockouts (full size only): ▼ K0= No knockouts K1= Knockouts for wiremold raceway
S472PBY4K0 = Sample part number	

Note: For replacement cover only, order part AC692KO or AC692K1 for full size, AC551 for compact.

### Explosionproof and flush-mount

S100147PD	Model number from table
Y	Number of leads: Y = 2 leads      Z = 3 leads
S100147PDY = Sample part number	



**STOCKED PARTS AVAILABLE**

Element	TCR Ω /Ω/°C	Compact room air sensors	Full size room air sensors	Explosion- proof wall-mount sensors	Flush mount room air sensors
RTDs					
Platinum 100 Ω ±0.1% at 0°C	0.00391	S405PB	S472PB		
Platinum 100 Ω ±0.1% at 0°C (Meets EN60751, Class B)	0.00385	▼ S448PD	▼ S473PD	S100147PD	S101456PD
Platinum 1000 Ω ±0.1% at 0°C	0.00385	▼ S449PF	▼ S474PF	S100148PF	S101456PF
Platinum 1000 Ω ±0.1% at 0°C	0.00375	S483PW	S489PW	S101608PW	S101456PW
Nickel-iron 1000 Ω ±0.12% at 70°F	0.00527	S403FB	S470FB		
Nickel-iron 2000 Ω ±0.12% at 70°F	0.00527	S404FC	S471FC		
HW 3000 Ω at -30.2°C	0.00262	S1000064PX	S1000063PX		
Thermistors <sup>R251</sup> / <sub>R125</sub>					
Thermistor 2,252 Ω ±1% at 25°C	29.2	TS426TA	TS424TA	TS100149TA	TS101769TA
Thermistor 10,000 Ω ±1% at 25°C	23.5	TS427TB	TS425TB	TS100150TB	TS101769TB

# Flexible Thermal-Ribbon™ Pipe Sensors

## Overview

Flexible Thermal-Ribbon™ sensors mount on the pipe surface so there's no expense of a pipefitter to drain, drill, and tap the pipe for a thermowell because there is no thermowell! When properly installed and insulated, the accuracy and response of a Thermal-Ribbon equals an immersed thermowell assembly.

Options include stainless steel braid over leadwires to prevent abrasion damage and pressure-sensitive adhesive for easier mounting (smooth surfaces only).

See Section 4 for optional 4 to 20 mA temperature transmitters.

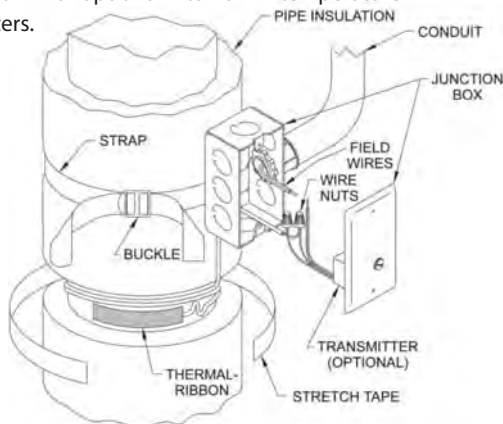

Note: Tape the Thermal-Ribbon in place beneath a layer of insulation.

## Mounting accessories:

### AC766 mounting kit

Provides a pipe-mounted enclosure for transmitters and connections. Kit includes junction box, 5 ft. nylon strap, buckle, 4 wire nuts, and 6 ft. of #20 stretch tape.

### #20 stretch tape

High temperature self-fusing silicone rubber tape for mounting Thermal-Ribbons to pipes. 1" wide rolls, 6 or 36 foot lengths.

### #6 RTV adhesive

Room temperature vulcanizing adhesive for attaching Thermal-Ribbons to surfaces. 3 oz. (89 ml) tube.

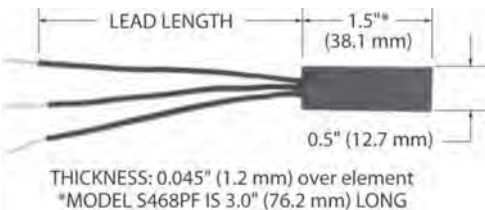

## Specifications

**Body material:** Silicone rubber with polyimide backing.

### Temperature range:

RTD: -62 to 200°C (-80 to 392°F).

Thermistor: -45.5 to 135°C (-50 to 275°F).

**Leadwires:** AWG 24, silicone rubber.

**Moisture resistance:** Meets MIL-STD-202, Method 104, Test Condition B.

## Model numbers

Element		TCR $\Omega / \Omega / ^\circ\text{C}$	Model
<b>RTDs</b>			
Platinum	100 $\Omega \pm 0.1\%$ at 0°C	0.00391	S464PB
Platinum	100 $\Omega \pm 0.1\%$ at 0°C (Meets EN60751, Class B)	0.00385	S467PD
Platinum	1000 $\Omega \pm 0.1\%$ at 0°C	0.00385	S468PF
Nickel-iron	1000 $\Omega \pm 0.12\%$ at 70°F	0.00527	S462FB
Nickel-iron	2000 $\Omega \pm 0.12\%$ at 70°F	0.00527	S463FC
HW	3000 $\Omega$ at -30.2°C	0.00262	S100001PX
<b>Thermistors</b>			
Thermistor	2,252 $\Omega \pm 1\%$ at 25°C	29.2	TS436TA
Thermistor	10,000 $\Omega \pm 1\%$ at 25°C	23.5	TS437TB

## Specification and order options

S467PD	Model number from table
Z	Number of leads: Y = 2 leads Z = 3 leads (RTD only) YS = 2 leads, stainless steel braid ZS = 3 leads, stainless steel braid (RTD only)
36	Lead length in inches
A	Adhesive backing: A = No adhesive B = Pressure-sensitive adhesive
S467PDZ36A = Sample part number	

HVAC SENSORS



**STOCKED PARTS AVAILABLE**

▼ = **STANDARD OPTIONS**  
Specifications subject to change



# Humidity Sensor/Transmitter Assembly



## Overview

Minco humidity and humidity/temperature transmitters are designed using an advanced microprocessor. Digital signal processing allows these transmitters to precisely match the characteristics of the humidity sensor to a wide range of RH and temperature values found in the many applications the product serves.

The humidity sensor is composed of an integrated circuit (IC) with a stable polymer element and platinum RTD that is used for temperature compensation. This sensor offers outstanding resistance to airborne contaminant and chemicals, and is protected by a sintered stainless steel filter which resists condensation.

- Wall/Duct/OSA mounting configurations
- Accuracies of  $\pm 1\%$  or  $\pm 2\%$  RH
- Temperature compensated
- Temperature output option
- Two-point field calibration
- NIST traceable calibrations

## Applications

Building environmental control systems (HVAC), hospitals, food storage, warehouses, clean rooms, pharmaceutical, freezers, drying equipment, and emissions monitoring.

## Specifications

### Ambient Temperature:

Operating:

Room:  $-10$  to  $150^{\circ}\text{F}$  ( $-23$  to  $65^{\circ}\text{C}$ ), non-condensing.

Wall/Duct/OSA:  $-10$  to  $185^{\circ}\text{F}$  ( $-23$  to  $85^{\circ}\text{C}$ ), non-condensing.

Storage:

Room:  $-58$  to  $150^{\circ}\text{F}$  ( $-50$  to  $65^{\circ}\text{C}$ ), non-condensing.

Wall/Duct/OSA:  $-58$  to  $185^{\circ}\text{F}$  ( $-50$  to  $85^{\circ}\text{C}$ ), non-condensing.

**Supply voltage:** 9.5 to 35 VDC, non-polarized.

**Voltage effect:**  $\pm 0.001\%$  of span/volt from 9.5 to 35 VDC.

**Loop resistance:** The maximum allowable resistance of the signal-carrying loop, including extension wires and load resistors, is given by this formula:  $R_{\text{loopmax}} = (V_{\text{supply}} - 9.5)/0.02 \text{ AMPS}$ . For example, if supply voltage is 24 VDC, the loop resistance must be less than  $725 \Omega$ .

**Adjustments:** Zero and span field adjustments, non-interacting.

**Time Constant:** 50 seconds in slow moving air.

**Connections:** Screw terminals (22-14 AWG wire).

### Weight:

Room: 0.19 lb (.084 kg).

Wall/Duct/OSA: 1.20 lb (0.55 kg).

**Minimum output current:** 3.5 mA

**Maximum output current:** 23 mA.

▼ = **STANDARD OPTIONS**  
Specifications subject to change

## Humidity Transmitter AH429 and AH439

**Output:** 4-20 mA DC = 0% to 100% RH.

**Sensing Element:** Capacitive monolithic IC.

**Accuracy:** Includes temperature, linearity, hysteresis, and repeatability.

- ±1% from 10% to 80% RH @ 25 to 35°C or
- ±2% from 0% to 90% RH @ 25°C
- (±3% from 0% to 90% RH @ 15 to 50°C)
- (±5% from 0% to 90% RH @ 0 to 82°C)

## Temperature Transmitter (AH439 only)

**Output:** 4-20 mA DC over the specified temperature range.

**Sensing element:** 1000 Ω platinum; 2 lead resistance thermometer, 0.00385 TCR.

**Accuracy:** Includes resistance thermometer tolerance, calibration accuracy, linearity, and ambient temperature effects.

- ±.75% of Temptran™ span for 32 to 122°F ambient.
- ±1.50% of Temptran™ span for -13 to 185°F ambient.

## AH429 Specification and order options

▼AH429	Model number:
R	Enclosure ▼D: Duct mount, 8" probe length ▼O: Outside Air/Wall mount, 4" probe length with shield, weather resistant enclosure ▼S: Space mount ▼W: Wall mount, 4" probe length, weather resistant enclosure R: Remote probe, 4" probe length
1	Output: 4 to 20 mA DC
N10	Calibration accuracy (humidity transmitter) ▼N10: ±1% from 10% to 80% (25 to 35°C) with NIST certificate N20: ±2% from 0% to 90% (25 to 35°C) with NIST certificate ▼S20: ±2% from 0% to 90% (25 to 35°C)
T1	Sensing element cover (omitted on "S" space mount models) T0= Sintered stainless steel; pressed on cover ▼T1= Sintered stainless steel; screw on cover T2= Slotted stainless steel; screw on cover (NA on "O" outside air models)
To order enclosure D, O, S or W, stop here. To order enclosure R (remote probe), add:	
A	Probe mounting location A = Side mounting B = Bottom mounting
48	Remote probe cable length (in inches) 48" and 96" are standard lengths
AH429R1N10T1A48 = Sample part number	

## AH429 = Humidity Transmitter

## AH439 = Humidity/Temperature Transmitter

## AH439 Specification and order options

▼AH439	Model number:
D	Enclosure ▼D: Duct mount, 8" probe length ▼O: Outside Air/Wall mount, 4" probe length with shield, weather resistant enclosure ▼S: Space mount W: Wall mount, 4" probe length, weather resistant enclosure R: Remote probe, 4" probe length
1	Outputs: 4 to 20 mA DC
N10	Calibration accuracy (humidity transmitter) ▼N10: ±1% from 10% to 80% (25 to 35°C) with NIST certificate N20: ±2% from 0% to 90% (25 to 35°C) with NIST certificate ▼S20: ±2% from 0% to 90% (25 to 35°C)
A	Temperature transmitter range ▼EN: -20°F to 140°F S: 0°F to 100°F ▼A: 20°F to 120°F Bl: 30°F to 130°F KK: 30°F to 180°F ▼N: 32°F to 122°F H: 40°F to 90°F More temperature range codes starting on page 4-20 or <a href="http://www.minco.com">www.minco.com</a>
T1	Sensing element cover (omitted on "S" space mount models) T0= Sintered stainless steel; pressed on cover ▼T1= Sintered stainless steel; screw on cover T2= Slotted stainless steel; screw on cover (NA on "O" outside air models)
To order enclosure D, O, S or W, stop here. To order enclosure R (remote probe), add:	
A	Probe mounting location A = Side mounting B = Bottom mounting
48	Remote probe cable length (in inches) 48" and 96" are standard lengths
AH439D1N10AT1A48 = Sample part number	

▼= STANDARD OPTIONS  
Specifications subject to change

# Hazardous Area Humidity Assembly



## Overview

Models AH71\_, AH72\_, and AH73\_ series are 2-wire temperature compensated humidity transmitters that are FM and CFM approved for use in hazardous locations. Intrinsically safe models are available with an optional temperature transmitter output. The AH73 is also available with an optional digital display for remote indication of relative humidity and temperature.

The transmitters utilize a thin film capacitive humidity sensor which provides outstanding sensitivity and chemical robustness. The transmitter converts the humidity sensor's signal into a 4 to 20 mA DC current, which changes proportionally from 4 mA at 0% RH to 20 mA at 100% RH. The optional temperature loop produces a second 4 to 20 mA DC output where the current changes from 4 mA at the lowest temperature of the range, to 20 mA at the top of the temperature range. The leads that supply power also carry the current signal.

- Accuracy of  $\pm 2.5\%$  RH
- Temperature compensated
- Temperature output option
- Two-point field calibration
- NIST traceable calibrations

## Applications

Building automation systems (HVAC), hospitals, food storage, warehouses, clean rooms, pharmaceutical, drying equipment, and emissions monitoring.

## Specifications

### Output(s):

Humidity: 4 to 20 mA DC = 0% to 100% RH.  
Temperature: 4 to 20 mA DC over specified range (optional)

**Humidity Range:** 0 – 100% RH

### Sensing Element:

Humidity: Thin film capacitive element.  
Temperature: 1000 ohm platinum RTD, 0.00385 TCR

**Temperature Effect:**  $\pm 0.03\%$  RH/ $^{\circ}\text{C}$   $\pm 1\%$  from  $10^{\circ}\text{C}$  to  $85^{\circ}\text{C}$

### Operating Temperature:

Transmitter:

- 40 to 176°F (-40 to 80°C), non-condensing.
- 4 to 176°F (-20 to 80°C), non-condensing, model AH73.

Sensor:

- 40 to 302°F (-40 to 150°C).

### Storage Temperature:

-58 to 185°F (-50 to 85°C), non-condensing.

### Supply voltage:

9.5 to 28 VDC for intrinsically safe (IS) models.  
16.5 to 28 VDC for explosionproof (XP) models.

**Voltage effect:**  $\pm 0.001\%$  of span/volt from 9.5 to 28 VDC.

**Loop resistance:** The maximum allowable resistance of the signal-carrying loop, including extension wires and load resistors, is given by this formula:

IS:  $R_{\text{loopmax}} = (V_{\text{supply}} - 9.5)/0.02 \text{ AMPS}$ . For example, if supply voltage is 24 VDC, the loop resistance must be less than 725  $\Omega$ .

XP:  $R_{\text{loopmax}} = (V_{\text{supply}} - 16.5)/0.02 \text{ AMPS}$ . For example, if supply voltage is 24 VDC, the loop resistance must be less than 375  $\Omega$ .

▼ = **STANDARD OPTIONS**  
Specifications subject to change

**Accuracy:** Includes linearity, hysteresis, repeatability, and voltage effects.  
 Humidity:  $\pm 2.5\%$  from 10% to 80% RH @ 25°C,  $\pm 3.5\%$  from 80% to 90% RH @ 25°C.  
 Temperature:  $\pm 0.5^\circ\text{F}$  ( $0.27^\circ\text{C}$ ) @ 77°F (25°C) or  $\pm 0.75\%$  of span, whichever is greater.

**Adjustments:** Zero and Span field adjustments, non-interacting.

**Time Constant:** 50 seconds in slow moving air.

**Connections:** Screw terminals (22-14 AWG wire).

**Weight:**

AH71\_ 2.84 lbs (1.29 kg).  
 AH72\_, AH73\_ 4.46 lbs (2.02 kg).

**Min. output current:** 3.8 mA.

**Max. output current:** 22 mA.

**Filter:** 60 micron stainless-steel sintered filter (replacement P/N : AC103512)

**Factory Mutual Approvals:**

Explosionproof with intrinsically safe sensor:  
 Suitable for the following hazardous area locations:  
 Class I, Division 1, 2, Groups B, C, D  
 Class II, Division 1, 2, Groups E, F, G  
 Class III, Division 1, 2

Intrinsically safe installation:  
 Suitable for the following hazardous area locations:  
 Class I, Division 1, 2, Groups A, B, C, D  
 Class II, Division 1, 2, Groups E, F, G  
 Class III, Division 1, 2  
 Class I, Zone 0, AEx ia IIC T4

Non-Incendive:  
 Suitable for the following hazardous area locations:  
 Class I, Division 2, Groups A, B, C, D  
 Class II, Division 2, Groups F, G  
 Class III, Division 2

**Transmitter entity parameters:**

$V_{max} = 28$  volts;  $I_{max} = 100$  mA;  $C_i = 0.037$   $\mu\text{F}$  and  $L_i = 0$  mH.

**Transmitter ranges:**

Code	Transmitter range
▼NT	No temperature transmitter
▼EN	-20°F to 140°F
S	0°F to 100°F
▼A	20°F to 120°F
BI	30°F to 130°F
KK	30°F to 180°F
▼N	32°F to 122°F
H	40°F to 90°F

**Accessories:**

Sintered Filter Replacement	Part Number: AC103512
Slotted Filter Replacement	Part Number: AC103513
Pipe Mounting Kit for AH72/AH73	Part Number: AC102765
Wall Mounting Kit for AH71	Part Number: AC103168
Duct Mounting Kit for AH71	Part Number: AC103253

**Specification and order options**

AH73	<b>Model number</b> ▼ AH71 Industrial grade humidity transmitter with optional temperature transmitter, CH106 connection head, display NA AH72 Industrial grade humidity transmitter with optional temperature transmitter, connection head, display NA ▼ AH73 Industrial grade humidity transmitter with optional temperature transmitter, connection head, display available		
1	<b>Probe diameter</b> ▼ 1 = 0.375"		
P3	<b>Pipe Thread Code</b>	<b>Process</b>	<b>Conduit</b>
	▼ P3	1/2 - 14NPT	1/2 - 14NPT
	P4	1/2 - 14NPT	3/4 - 14NPT
	P5	G1/2A	1/2 - 14NPT
	P6	G1/2A	3/4 - 14NPT
L120	<b>Probe length</b> ▼ L60 = 6" ▼ L120 = 12"		
T1	<b>Filter type</b> ▼ T1 = Sintered stainless steel T2 = Slotted stainless steel		
HT490	<b>Transmitter model number</b> ▼ HT480 = Explosionproof with intrinsically safe sensor (transmitter code NT only) ▼ HT490 = Intrinsically safe		
F	<b>Display</b> C = Display, metric units (AH73_series only) ▼ F = Display, English units (AH73_series only) ▼ N = No display (AH71_ and AH72_ series only)		
1	<b>Signal output</b> ▼ 1 = 4 to 20mA		
N25	<b>Calibration accuracy</b> (humidity transmitter) ▼ N25 $\pm 2.5\%$ from 10% to 80% (25°C) with NIST certificate S25: $\pm 2.5\%$ from 10% to 80% (25°C)		
EN	<b>Temperature transmitter range from table</b>		
AH731P3L120T1HT490F1N25EN = Sample part number			

HVAC SENSORS

▼ = STANDARD OPTIONS  
 Specifications subject to change



# Intrinsically Safe Humidity Assembly



## Overview

Models AH74 and AH75 are 2-wire temperature compensated humidity transmitters that are FM and CFM approved as intrinsically safe for use in hazardous locations. Both models are available with an optional temperature transmitter output. AH75 incorporates a digital display for remote indication of relative humidity and temperature.

The transmitters utilize a thin film capacitive humidity sensor which provides outstanding sensitivity and chemical robustness. The transmitter converts the humidity sensor's signal into a 4 to 20 mA DC current, which changes proportionally from 4 mA at 0% RH to 20 mA at 100% RH. The optional temperature loop produces a second 4 to 20 mA DC output where the current changes from 4 mA at the lowest temperature of the range, to 20 mA at the top of the temperature range. The leads that supply power also carry the current signal.

- Accuracy of  $\pm 2.5\%$  RH
- Temperature compensated
- Temperature output option
- Two-point field calibration
- NIST traceable calibrations

## Applications

Building automation systems (HVAC), hospitals, food storage, warehouses, clean rooms, pharmaceutical, drying equipment, and emissions monitoring.

## Specifications

### Output(s):

Humidity: 4 to 20 mA DC = 0% to 100% RH.  
Temperature: 4 to 20 mA DC over specified range (optional).

**Humidity Range:** 0 – 100% RH

### Sensing Element:

Humidity: Thin film capacitive element.  
Temperature: 1000 ohm platinum RTD.

**Temperature Effect:**  $\pm 0.03\%$  RH/ $^{\circ}\text{C}$   $\pm 1\%$  from  $10^{\circ}\text{C}$  to  $85^{\circ}\text{C}$

### Operating Temperature:

Transmitter:

- 40 to  $176^{\circ}\text{F}$  ( $-40$  to  $80^{\circ}\text{C}$ ), non-condensing.
- 4 to  $176^{\circ}\text{F}$  ( $-20$  to  $80^{\circ}\text{C}$ ), non-condensing, model AH75.

Sensor:

- 40 to  $176^{\circ}\text{F}$  ( $-40$  to  $80^{\circ}\text{C}$ ),

### Storage Temperature:

-58 to  $185^{\circ}\text{F}$  ( $-50$  to  $85^{\circ}\text{C}$ ), non-condensing.

**Supply voltage:** 9.5 to 28 VDC .

**Voltage effect:**  $\pm 0.001\%$  of span/volt from 9.5 to 28 VDC.

**Loop resistance:** The maximum allowable resistance of the signal-carrying loop, including extension wires and load resistors, is given by this formula:  $R_{\text{loopmax}} = (V_{\text{supply}} - 9.5)/0.02 \text{ AMPS}$ .

**Accuracy:** Includes linearity, hysteresis, repeatability, and voltage effects.

Humidity:  $\pm 2.5\%$  from 10% to 80% RH @  $25^{\circ}\text{C}$ ,  $\pm 3.5\%$  from 80% to 90% RH @  $25^{\circ}\text{C}$ .

Temperature:  $\pm 0.5^{\circ}\text{F}$  ( $0.27^{\circ}\text{C}$ ) @  $77^{\circ}\text{F}$  ( $25^{\circ}\text{C}$ ) or  $\pm 0.75\%$  of span, whichever is greater.

**Adjustments:** Zero and Span field adjustments, non-interacting.

**Time Constant:** 50 seconds in slow moving air.

**Connections:** Screw terminals (22-14 AWG wire).

### Weight:

AH74            0.54 lbs (245 g).  
AH75            0.61 lbs (276 g).

**Min. output current:** 3.8 mA.

**Max. output current:** 22 mA.

**Filter:** 60 micron stainless-steel sintered filter  
(replacement P/N : AC103512)

### Factory Mutual Approvals:

Intrinsically safe:

- Suitable for the following hazardous area locations:  
Class I, Division 1, Groups A, B, C, D  
Class I, Zone 0, AEx ia IIC T4

Non-Incendive:

- Suitable for the following hazardous area locations:  
Class I, Division 2, Groups A, B, C, D

### Transmitter entity parameters:

$V_{\text{max}} = 28 \text{ volts}$ ;  $I_{\text{max}} = 100 \text{ mA}$ ;  $C_i = 0.037 \mu\text{F}$  and  $L_i = 0 \text{ mH}$ .

▼ = STANDARD OPTIONS  
Specifications subject to change



**Transmitter ranges:**

Code	Transmitter range
▼NT	No temperature transmitter
EN	-20°F to 140°F
S	0°F to 100°F
▼A	20°F to 120°F
BI	30°F to 130°F
KK	30°F to 180°F
N	32°F to 122°F
H	40°F to 90°F

**Specification and order options**

AH75	<p><b>Model Number:</b></p> <ul style="list-style-type: none"> <li>▼AH74 - Humidity Transmitter with Optional Temperature Transmitter, No Display</li> <li>▼AH75 - Humidity Transmitter with Optional Temperature Transmitter, with Display</li> </ul>
1	<p><b>Probe Diameter:</b> 1 = 0.375"</p>
C3	<p><b>Probe Location / Cable Bushings Option:</b> Please refer to dimensional drawings for probe Location.</p> <ul style="list-style-type: none"> <li>C1 = Probe Location A (Rear) / Single Cable Gland</li> <li>C2 = Probe Location A (Rear) / Dual Cable Glands</li> <li>▼C3 = Probe Location A (Rear) / Single Conduit Fitting, 1/2" NPT</li> <li>▼C4 = Probe Location A (Rear) / Dual Conduit Fittings, 1/2" NPT</li> <li>▼C5 = Probe Location B (Bottom) / Single Cable Gland</li> <li>▼C6 = Probe Location B (Bottom) / Dual Cable Glands</li> <li>▼C7 = Probe Location B (Bottom) / Single Conduit Fitting, 1/2" NPT</li> <li>▼C8 = Probe Location B (Bottom) / Dual Conduit Fittings, 1/2" NPT</li> </ul> <p><i>Note: If a temperature loop is desired, dual cable glands or dual conduit fittings must be selected unless special cable is used during installation. Please refer to National Electrical Code ANSI/NFPA 70 for installation in accordance with US requirements, or Canadian Electrical Code, C22.1 for installation in accordance with Canadian requirements.</i></p>
L40	<p><b>Probe Length:</b> ▼L40 = 4"</p>
T1	<p><b>Filter Type:</b></p> <ul style="list-style-type: none"> <li>▼ T1 = Sintered Stainless Steel</li> <li>T2 = Slotted Stainless Steel</li> </ul>
HT490	<p><b>Transmitter Model Number:</b></p> <ul style="list-style-type: none"> <li>▼ HT490 = Intrinsically Safe Transmitter</li> </ul>
F	<p><b>Display:</b></p> <ul style="list-style-type: none"> <li>C = Display, Metric Units (AH75_ Series Only)</li> <li>▼ F = Display, English Units (AH75_ Series Only)</li> <li>▼ N = No Display</li> </ul>
1	<p><b>Signal Output:</b> ▼1 = 4-20mA</p>
N25	<p><b>Calibration Accuracy:</b></p> <ul style="list-style-type: none"> <li>▼ N25 = ±2.5% from 10% to 80% (25°C) with NIST Certificate</li> <li>S25 = ±2.5% from 10% to 80% (25°C)</li> </ul>
NT	<p><b>Temperature Transmitter Range from table:</b> ▼A, NT</p>
<p>AH751C3L40T1HT490F1N25NT = Sample part number</p>	

**Dimensions:  
Probe Location A**

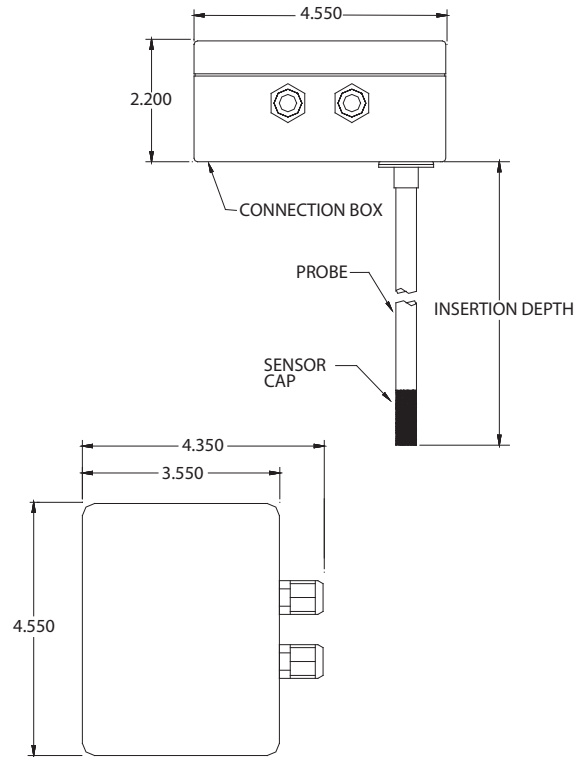

**Probe Location B**

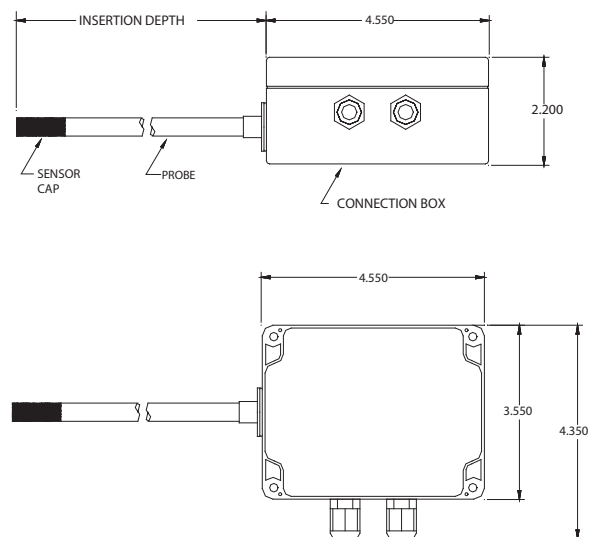

HVAC SENSORS

▼ = STANDARD OPTIONS  
Specifications subject to change

# Thermal Vial™ Temperature Sensing System



## Overview

- Ideal for ultralow freezers, laboratories, blood banks, walk-in freezers and refrigerators, even incubators—anywhere accurate sensing of the contents instead of the air is a vital concern.
- Sealed Polyethylene Thermal Vial™ eliminates spillage and contamination. Simply fill with fluid such as ethylene glycol, alcohol, water, or a cryopreservative to accurately emulate the material being stored or processed.
- Large (50 mm x 50 mm) footprint of the single well vial provides stability on a shelf or rack. Holds 175 ml (6 oz) of fluid. Other vial configurations are available. See next page.
- Platinum RTD probe is constructed of 316 Stainless Steel and operates to -200°C (-328°F).
- Metal shielded cable is rugged and washdown proof.
- 4 to 20 mA transmitter is match calibrated to the RTD for improved system accuracy.
- System accuracy is a variable
- NIST certificate and calibration data supplied at no additional cost.
- Additional accessories available.
- Customizable for validation requirements.
- Connection box and indicator are polycarbonate and NEMA 4X sealed to be washdown proof.

## Specifications

**Probe case:** Stainless steel.

**Element:** Platinum.

**Resistance (excluding leadwire resistance):**

PM platinum: 100.00 Ω ±.06% at 0°C (32°F) (Class A).

PD platinum: 100.00 Ω ±.12% at 0°C (32°F) (Class B).

PF platinum: 1000.00 Ω ±.12% at 0°C (32°F).

**TCR:** .00385 Ω/Ω/°C nominal from 0°C to 100°C.

**Operating temperature range:**

Probe and vial: -200 to 120°C (-328 to 248°F).

Transmitter: -25 to 85°C (-13 to 185°F).

**Insulation resistance:** 1000 megohms minimum at 500 VDC, leads to probe case.

**Leads:** AWG #22, stranded, TFE insulated, with TFE jacket overall.

**Thermal vial:** Polyethylene bottle with cap.

**Thermowell:** Delrin material.

**Transmitter:** 4-20 mA output; 8.5 to 35 VDC loop powered.

**Connection box:** Polycarbonate enclosure, NEMA 4X.

## Specification and order options

AS103282	Model number
PM	Sensing element, .00385 TCR: ▼ PM = 100 Ω Platinum ±.06%, Class A PD = 100 Ω Platinum ±.12%, Class B PF = 1000 Ω Platinum ±.12%
60	Cable length in inches ▼: 60, 120
D	Vial configuration: ▼ S = Single thermowell, standard vial ▼ D = Dual thermowell T = Triple thermowell ▼ M = Single thermowell, miniature vial L = Single thermowell, large vial
C	Connection box type: ▼ C = Indicating °C      ▼ F = Indicating °F ▼ B = Non-indicating
20	System accuracy: 75 = .75% of span      50 = .50% of span ▼ 20 = .20% of span or .1°C, whichever is greater
EZ	Temptran temperature range code: ▼ EZ = -100/0°C (-148/32°F) ▼ M = -50/50°C (-58/122°F) C = 0/100°C (32/212°F) More ranges starting on page 4-20.
AS103282PM60DC20EZ = Sample part number	

▼ = **STANDARD OPTIONS**  
 Specifications subject to change

# Thermal Vial™ Accessories

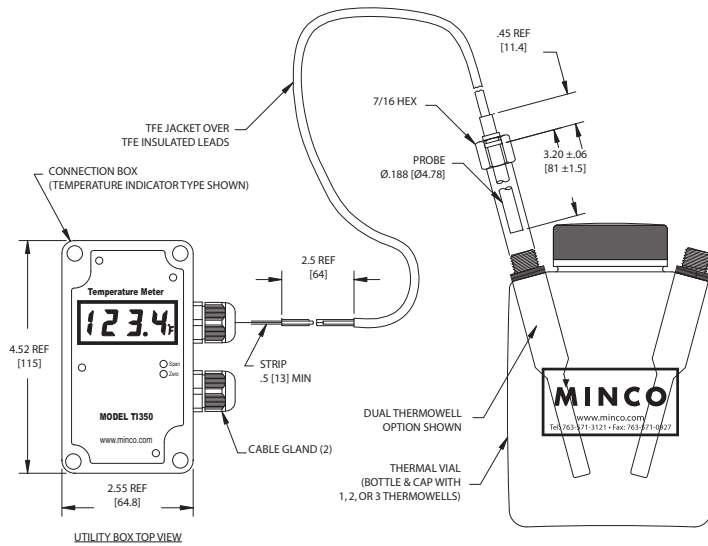

## Available Accessories

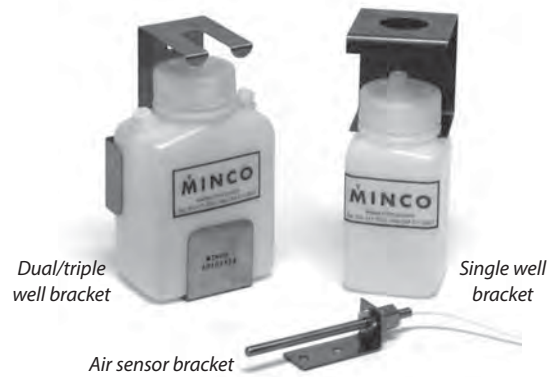

Description	Capacity		Model
	6 oz.	175 ml	
Single	8 oz.	250 ml	AC101394
Dual	8 oz.	250 ml	AC102026
Triple	8 oz.	250 ml	AC102647
Mini	2 oz.	60 ml	AC103316
Large	32 oz.	1000 ml	AC102551

Description	Model
Single well bracket	AC101540
Dual/triple well bracket	AC102732
Air sensor bracket	AC102074

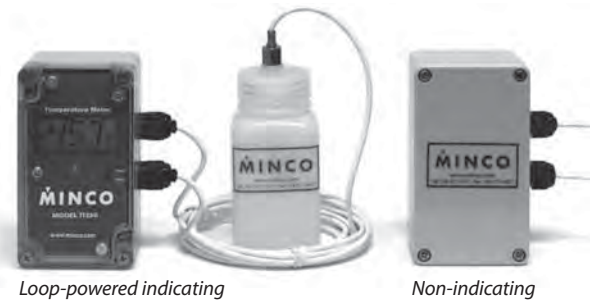

Description	Model
Loop-powered indicating	TI350
Non-indicating	CH102777

▼ = STANDARD OPTIONS  
Specifications subject to change

# Refrigeration & Freezer Temperature System

## Overview

- Ideal for refrigerated rooms, freezers, cold storage facilities and laboratories — anywhere an accurate, rugged, and weatherproof temperature sensor is needed.
- 100  $\Omega$  platinum RTD probe is constructed of 316 stainless steel to be resistant to most chemicals, including ammonia. Operates to -452°F (-269°C).
- 4 to 20 mA transmitter is epoxy potted to protect circuitry from condensation and ice. Operates in ambient temperatures down to -13°F (-25°C).
- Transmitter is match calibrated to RTD for 0.75% system accuracy. Free NIST certificate.
- Enclosure is gasketed and moisture resistant.
- RTD probe is available in lengths ranging from 2 inches to 48 inches, and the probe can be center-mounted for through-the-wall installation, or end-mounted for flush-to-the-wall mounting.

## Specifications

### Temperature range:

Probe: -269 to 260°C (-452 to 500°F).

Transmitter: -25 to 85°C (-13 to 185°F).

**RTD probe:** 100  $\Omega$  platinum, 0.00385 TCR.

**Transmitter:** 4-20 mA output, 8.5 to 35 VDC loop powered.

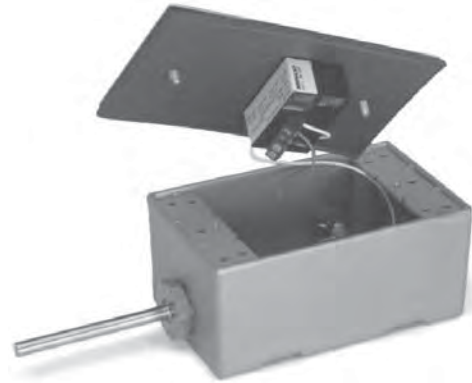
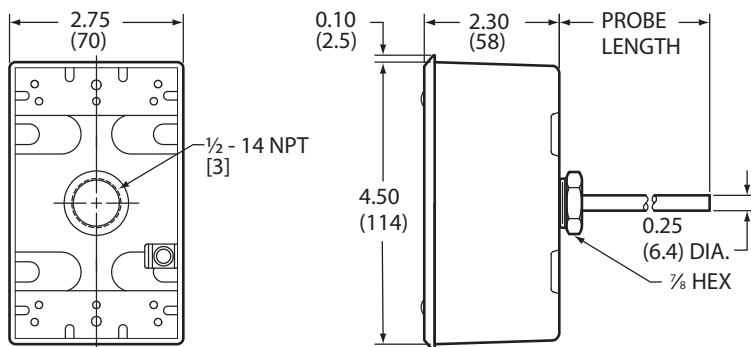

## Specification and order options

AS100279	Assembly number
PD	100 $\Omega$ platinum RTD
67	<b>Probe length:</b> Specify in 0.1" increments (Ex: 67 = 6.7 inches)
M	<b>Temperature range for 4-20 mA output:</b> M = -50 to 50°C (-58 to 122°F) AD = -40 to 48.9°C (-40 to 120°F) DN = -30 to 50°C (-22 to 122°F) S = -18 to 37.8°C (0 to 100°F) BY = -10 to 40°C (14 to 104°F) Other ranges are available starting on page 5-20.
AS100279PD67M = Sample part number	

▼ = **STANDARD OPTIONS**  
Specifications subject to change

# Fluid Immersion Temperature Sensors

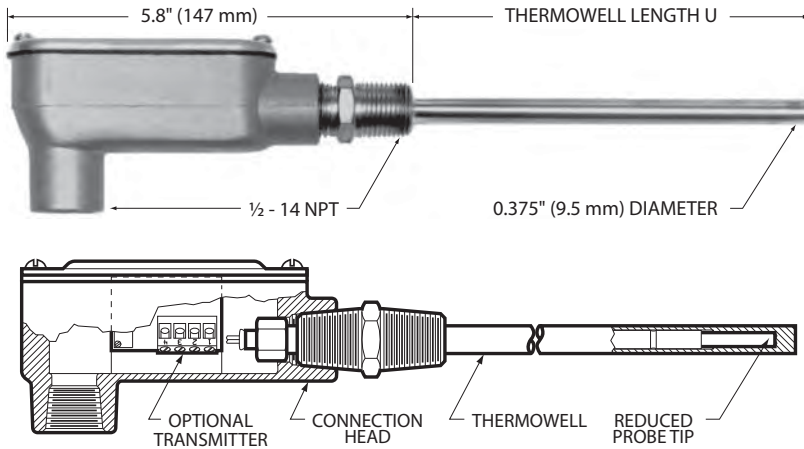

## Overview

Immersion sensors include stainless steel thermowells for insertion directly into fluid streams. The sensing probe may be removed without breaking the fluid seal. Brass thermowells are also available.

See page 4-2 for optional 4 to 20 mA temperature transmitters.

## Specifications

**Temperature range:** -45.5 to 260°C (-50 to 500°F).

**Leadwires:** AWG 22, PTFE insulated, 4" (100 mm) long.

**Thermowell pressure rating:** 1880 psi (130 bar).

**Moisture resistance:** Meets MIL-STD-202, Method 104, Test Condition B.



**STOCKED PARTS AVAILABLE**

## Model numbers

Element	TCR Ω/Ω/°C	Model number
Platinum 100 Ω ±0.1% at 0°C	0.00391	▼ S478PB
Platinum 100 Ω ±0.1% at 0°C (Meets EN60751, Class B)	0.00385	▼ S479PD
Platinum 1000 Ω ±0.1% at 0°C	0.00385	▼ S480PF
Platinum 1000 Ω ±0.1% at 0°C	0.00375	▼ S490PW*
Nickel-iron 1000 Ω ±0.12% at 70°F	0.00527	▼ S476FB*
Nickel-iron 2000 Ω ±0.12% at 70°F	0.00527	S477FC*
HW 3000 Ω at -30.2°C	0.00262	S100061PX*

\* Maximum temperature is 130°C (266°F).

Note: These sensors are intended for use in slow-moving fluid streams. For applications where fluid velocity exceeds 3 ft/s, you may need to use a thermowell assembly as an alternative. Contact Minco Sales and Customer Service for additional information.

## Specification and order options:

### Fluid immersion temperature sensors

S479P	D Model number from table
Y	Number of leads: ▼ Y = 2 leads Z = 3 leads
60	Thermowell length U: Specify in 0.1" increments (Ex: 60 = 6.0 inches) ▼ : 20, 30, 60 Contact factory for other lengths
S479PDY60 = Sample part number	

## Replacement stainless steel thermowells

TW488	Model number
U	
60	Thermowell length U: Specify in 0.1" increments (Ex: 60 = 6.0 inches) Standard thermowell lengths are 3" and 6", contact factory for other lengths
TW488U60 = Sample part number	

## To order with transmitter, add

TT111	Transmitter Models TT111: Fixed Range (2 leads) TT211: Fixed Range (2 leads) TT321: Fixed Range (3 leads) <i>Contact for other transmitter options.</i>
A	Temperature Range Code: A = 20°F to 120°F (-6.7°C to 48.9°C) <i>Contact for complete list of available temp. codes.</i>
1	Calibration: 1 = Nominal Calibration 2 = Match Calibrated, 0.75% Total System Accuracy 3 = Match Calibrated, 0.5% Total System Accuracy 4 = Match Calibrated, 0.2% or 1°C Total System Accuracy <i>Contact for other calibration options.</i>
TT111A1 = Sample part number addition	

Specifications subject to change



# Elements & Probes

## Overview

These models feature fast-responding RTD or thermistor elements in aluminum cases (except stainless steel on S482PW) with PTFE insulated leadwires. They can be assembled into probes or used separately as all-purpose sensors.

Probes consist of elements assembled into stainless steel extension tubes. They are not suitable for direct fluid immersion but may be used with thermowells. See Section 3 for thermowell options.

See Section 4 for optional 4 to 20 mA temperature transmitters.

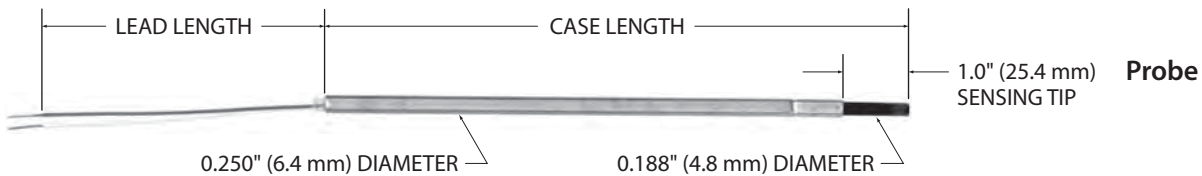

## Element

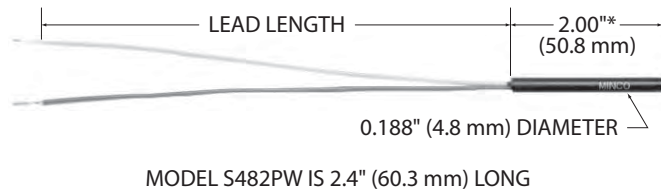

## Specifications

**Temperature range:** -45.5 to 135°C (-50 to 275°F).

**Leadwires:** AWG 22, PTFE insulated. Standard lengths are 4", 12" and 18".

**Moisture resistance:** Meets MIL-STD-202, Method 104, Test Condition B.

**Insulation resistance:** 1000 megohms min. at 500 VDC, leads to case.

## Model numbers

Element	TCR Ω / Ω/°C	Elements	Probes
RTDs			
Platinum 100 Ω ±0.1% at 0°C	0.00391	S402PB	411PB
Platinum 100 Ω ±0.1% at 0°C (Meets EN60751, Class B)	0.00385	S458PD	S460PD
Platinum 1000 Ω ±0.1% at 0°C	0.00385	S459PF	S461PF
Platinum 1000 Ω ±0.1% at 0°C	0.00375	S482PW	S485PW
Nickel-iron 1000 Ω ±0.12% at 70°F	0.00527	S400FB	S409FB
Nickel-iron 2000 Ω ±0.12% at 70°F	0.00527	S401FC	S410FC
HW 3000 Ω at -30.2°C	0.00262	S100057PX	S100837PX
Thermistors			
Thermistor 2,252 Ω ±1% at 25°C	R25/R125 29.2	TS438TA	TS440TA
Thermistor 10,000 Ω ±1% at 25°C	23.5	TS439TB	TS441TB

## Specification and order options:

### Probes

S411PB	Model number from table
60	Case length: Specify in 0.1" increments (Ex: 60 = 6.0 inches) Minimum length is 3"
Z	Number of leads: Y = 2 leads Z = 3 leads (platinum only)
4	Lead length in inches
S411PB60Z4 = Sample part number	

### Elements

S458PD	Model number from table
Z	Number of leads: Y = 2 leads Z = 3 leads (platinum only)
4	Lead length in inches
S458PDZ4 = Sample part number	

## To order with transmitter, add

TT111	Transmitter Models TT111: Fixed Range (2 leads) TT211: Fixed Range (2 leads) TT321: Fixed Range (3 leads) <i>Contact for other transmitter options.</i>
A	Temperature Range Code: A = 20°F to 120°F (-6.7°C to 48.9°C) <i>Contact for complete list of available temp. codes.</i>
1	Calibration: 1 = Nominal Calibration 2 = Match Calibrated, 0.75% Total System Accuracy 3 = Match Calibrated, 0.5% Total System Accuracy 4 = Match Calibrated, 0.2% or 1°C Total System Accuracy <i>Contact for other calibration options.</i>
TT111A1 = Sample part number addition	



**STOCKED PARTS AVAILABLE**

*Specifications subject to change*

# Temptran™ 4 to 20 mA Transmitters

Most HVAC sensors are available with companion 4 to 20 mA transmitters. See page 4-2 for suitable models. (Room air thermometers use model TT115, which has the same specifications as TT111). Temptran™ temperature transmitters convert low-level RTD output to a standard current signal that is immune to lead resistance and electrical noise. You can get accurate readings from points thousands of feet away.

## How to order transmitters

To order HVAC/R sensors with integral transmitters, specify both the RTD and the Temptran part numbers.

## High-accuracy calibration

Standard transmitters are calibrated to the nominal resistance values of the RTD at the zero and span points. Total system error includes the tolerance of both the transmitter and the RTD sensor.

If you order Minco Temptrons calibrated to the actual resistance of the RTD (as measured in Minco's metrology lab), this effectively subtracts the sensor tolerance from system accuracy specifications.

For example, consider a transmitter with a range of 0 to 500°C. The transmitter itself is accurate to  $\pm 1.0^\circ\text{C}$  ( $\pm 0.2\%$  of span, including calibration accuracy and linearity). The RTD interchangeability contributes an additional error of  $\pm 0.3^\circ\text{C}$  at  $0^\circ\text{C}$  and  $\pm 2.8^\circ\text{C}$  at  $500^\circ\text{C}$ . Total system error would be  $\pm 1.3^\circ\text{C}$  at  $0^\circ\text{C}$  and  $\pm 3.8^\circ\text{C}$  at  $500^\circ\text{C}$ . When you calibrate the sensor and transmitter as a set, the sensor error disappears, reducing system error to  $\pm 1.0^\circ\text{C}$  over the full range — all for a nominal extra cost.

## 0.75% guaranteed accuracy

Minco guarantees a system accuracy (current signal vs temperature) of 0.75% of span when you order specially calibrated Temptrons with any RTD in the HVAC/R Sensors Section. (An RTD with standard transmitter will deviate about 1-2% of span.) Tighter accuracies are available on special order.



Transmitters are mounted in the junction box on duct sensors, or in the connection head of fluid immersion sensors.

Outside air thermometers and Thermal-Ribbons: Transmitters are furnished separately. Install in an enclosure near the sensor, but away from excessive ambient temperatures.

Full size wall mount thermometers use the TT115 circuit-board style Temptran. The enclosure is thermally designed to minimize heating of the sensor by transmitter electronics.

## Free NIST traceability

With each matched sensor/transmitter set, Minco sends you calibration data traceable to the National Institute of Standards & Technology. This helps you comply with ISO 9001 and other quality standards.

## Recalibration

Minco prints RTD resistance values right on the Temptran label to simplify recalibration. You simply connect a resistance decade box or "RTD simulator" in place of the RTD, dial in the correct values, and adjust zero and span. Because Minco RTDs shift less than  $0.05^\circ\text{F}$  per year in a typical HVAC installation, the printed values remain valid for many years.

MINCO MINCO, INC. USA	MODEL	TEMPTRAN™		
	D/C: 9614			
	100 OHM PLATINUM RTD			
	4mA=	20.0°F=	-6.7°C=	97.932Ω
	20mA=	120.0°F=	48.9°C=	118.969Ω

RTD resistances are printed on Temptran labels for easy recalibration of zero and span. A standard Temptran shows nominal values.

MINCO MINCO, INC. USA	MODEL	TEMPTRAN™		
	D/C: 9614 S/N: 103			
	100 OHM PLATINUM RTD			
	4mA=	20.0°F=	-6.7°C=	97.427Ω
	20mA=	120.0°F=	48.9°C=	118.988Ω

A specially calibrated Temptran shows actual resistance of the serialized, connected RTD.

See Section 4 for complete details and ordering information.

▼ = STANDARD OPTIONS  
Specifications subject to change





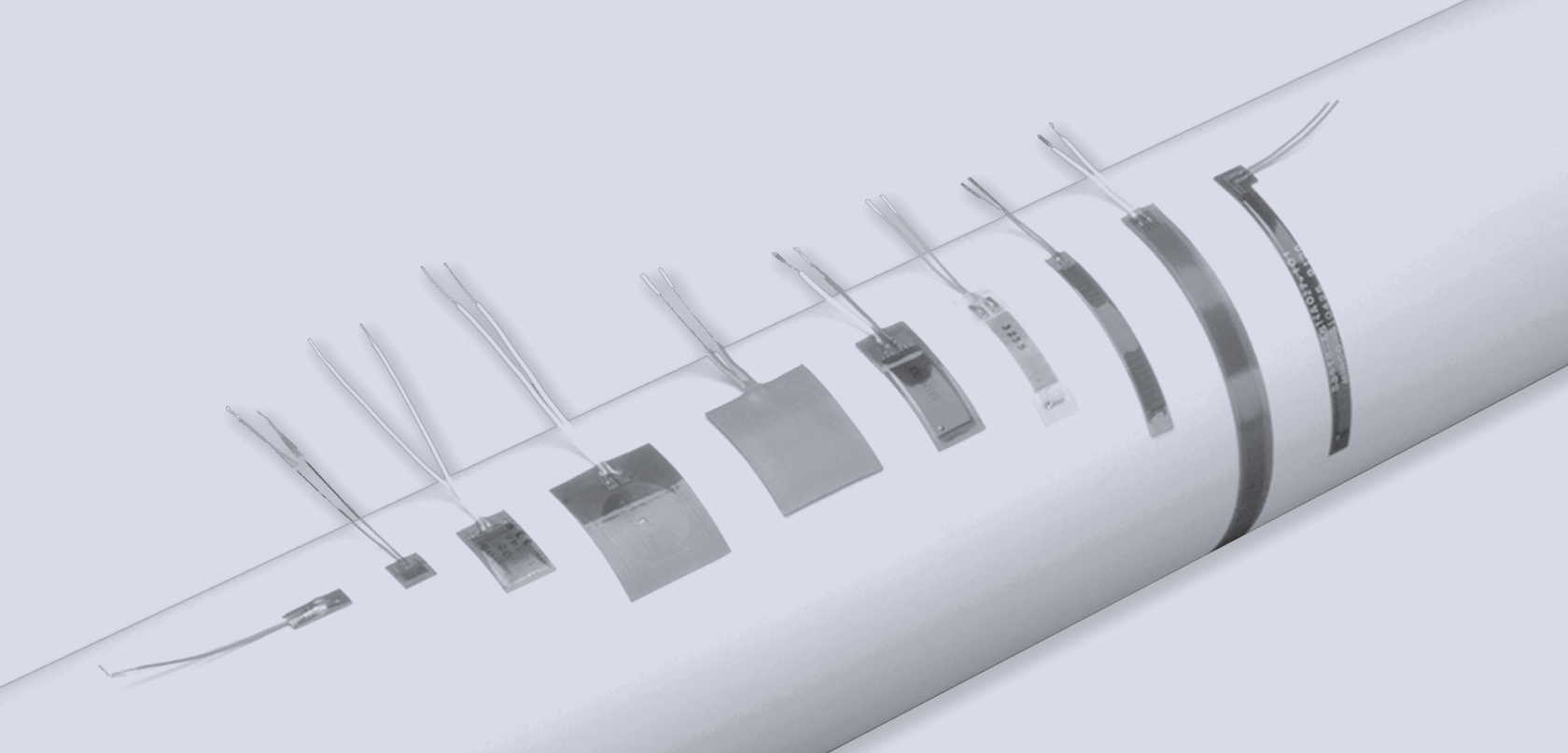

## ▶ SECTION 9: THERMAL-RIBBONS™

- Fast response surface sensing in aerospace, medical, and industrial devices
- Thin, flexible RTDs and thermocouples offer easy, non-invasive installation
- Rugged laminated construction for use in extreme environments
- Polyimide, silicone rubber, Mylar™ insulation









Thermal-Ribbons™ .....	9-2 to 9-3
Thermal-Tabs™ .....	9-2 to 9-3
Discoil™ Thermal-Ribbons .....	9-4
Strip sensing Thermal-Ribbons .....	9-5
Thermistor Thermal-Ribbons .....	9-6
Thermocouple Thermal-Ribbons .....	9-6
Installation and accessories .....	9-7

# Thermal-Tab™ and Thermal-Ribbon™ Sensors

Install these compact sensors anywhere for accurate point sensing and fast response. All Thermal-Tab modules use a thin-film RTD element. All Thermal-Ribbon models conform to EN60751 Class B tolerance when ordered with a PD platinum element.

- Fast response surface sensing in aerospace, medical and industrial devices
- Rugged lamination construction
- Polyimide, silicone rubber or Mylar™ insulation
- All models are RoHS compliant

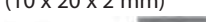
## Thermal-Tab Specifications

Dimensions W x L x T <sub>max</sub>	Element options	Insulation	Temperature range	Leadwires	Time constant*	Features	Model
0.20 x 0.50 x 0.08" (5 x 12 x 2 mm) 	▼: PD, PF	Polyimide with elastomer cover coat	-50 to 155°C -58 to 311°F	AWG 26, PTFE insulated	0.8 sec.	Stocked for immediate shipment	▼S665
0.20 x 0.60 x 0.08" (5 x 15 x 2 mm) 	▼: PD, PF, PW, PS	Polyimide	-50 to 200°C -58 to 392°F	AWG 26, PTFE or polyimide insulated	1.0 sec.	Platinum models in stock	▼S17624
0.20 x 0.60 x 0.08" (5 x 15 x 2 mm) 	▼: PD, PF	Polyimide film	-50 to 260°C -58 to 500°F	AWG 26, PTFE or polyimide insulated	0.4 sec.	Highest temperature capability	S100820
0.20 x 0.60 x 0.12" (5 x 15 x 3 mm) 	▼: PD, PF	Silicone rubber with elastomer cover and foil backing	-50 to 155°C -58 to 311°F	AWG 24, Silicone insulated	1.3 sec.	Waterproof; suitable for continuous immersion	S667
0.20 x 0.60 x 0.045" (5 x 15 x 1.15 mm) 	▼: PD, PF	Polyimide film	-50 to 200°C -58 to 392°F	AWG 26, PTFE or polyimide insulated	0.6 sec.	Thinnest profile	S100725
0.30 x 0.60 x 0.10" (7 x 15 x 2.5 mm) 	▼: PD, PF	Polyimide film	-50 to 200°C -58 to 392°F	AWG 22, PTFE or polyimide insulated	1.2 sec.	Heavier leadwire for applications requiring ruggedized design	S100724
0.40 x 0.80 x 0.08" (10 x 20 x 2 mm) 	▼: PD, PF	Polyimide film	-50 to 200°C -58 to 392°F	AWG 26, PTFE or polyimide insulated	0.9 sec.	Larger surface area for easier handling and maximum adhesive bond	S100723
0.40 x 0.80 x 0.08" (10 x 20 x 2 mm) 	▼: PD, PF	Silicone rubber	-50 to 220°C -58 to 428°F	AWG 26, PTFE or polyimide insulated	1.5 sec.	High temperature rating, available with wide range of element options	S100721

## Thermal-Ribbon Specifications

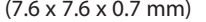
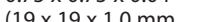
0.20 x 1.50 x 0.030" (5.1 x 38.1 x 0.8 mm) 	▼FA	Polyimide	-200 to 200°C -328 to 392°F	AWG 34, PTFE insulated	0.15 sec.	Wire-wound nickel-iron for high resistance in small package	▼S38
0.30 x 0.30 x 0.025" (7.6 x 7.6 x 0.7 mm) 	▼PD PE	Polyimide with foil backing	-200 to 200°C -328 to 392°F	AWG 28, PTFE insulated	0.15 sec.	Wire-wound element	▼S651
0.75 x 0.75 x 0.04" (19 x 19 x 1.0 mm) 	▼FA	Mylar	-200 to 150°C -328 to 302°F	AWG 30, PTFE insulated	0.3 sec.	Wire-wound nickel-iron flat element for high resistance	▼S25

Notes: T<sub>max</sub> is measured over the lead bulge. \*Time constant is in water at 1 m/sec.

## Specifications, continued

Leadwire insulation codes	
S25, S38, S651, S665, S667	Leave blank
S17624, S100721, S100723, S100724, S100725, S100820	▼T = PTFE insulated wires

▼ = STANDARD OPTIONS  
Specifications subject to change

## Sensing elements

Sensing element specifications**		Code
Platinum (0.00385 TCR) (EN60751, Class B)	100 $\Omega$ $\pm$ 0.12% at 0°C	PD
Platinum (0.00385 TCR)	100 $\Omega$ $\pm$ 0.22% at 0°C	PE
Platinum (0.00385 TCR)	1000 $\Omega$ $\pm$ 0.12% at 0°C	PF
Platinum (0.00375 TCR)	1000 $\Omega$ $\pm$ 0.12% at 0°C	PW
Platinum (0.00385 TCR)	10,000 $\Omega$ $\pm$ 0.12% at 0°C	PS
Nickel-iron (0.00518 TCR)	604 $\Omega$ $\pm$ 0.26% at 0°C	FA
Nickel (0.00618 TCR) (DIN43760 Ni100, Class B)	100 $\Omega$ $\pm$ 0.22% at 0°C	NB

\*\* See table on previous page for element options on each model.

### Waterproof model

Model S667 is waterproof and suitable for continuous immersion. Use it to monitor the temperature of water in a tank or container, or on equipment that must withstand wash-down or immersion.

Check with Minco for suitability in other liquids.



## Specification and order options

S17624	Model number from table
PD	Sensing element from table
Z	Number of leads: ▼ Y = 2 leads   ▼ Z = 3 leads (N/A on S25, S38) X = 4 leads (N/A on S25, S38 or S665/S667)
T	Leadwire insulation code from table at left
12	Lead length in inches: S665/S667: 60" max. ▼: 12, 36, 120
A	Adhesive backing: ▼ A = No adhesive ▼ B = Pressure-sensitive adhesive (PSA)
Stop here for all models except S665 or S667. For models S665 and S667, add:	
C	Compliance: C = RoHS Compliance
S665PDZT12AC = Sample part number	

Notes: PSA reduces temperature range to -20 to 177°C (-4 to 350°F) and adds 0.005" (0.1 mm) to thickness.

### Custom Thermal-Ribbon designs

Minco can custom-wind Thermal-Ribbon elements in virtually any shape and size. We can profile sensing elements to provide increased sensitivity in selected zones, and provide packaging to perfectly fit your applications.

Contact Minco Sales and Customer Service today to discuss your application.



**STOCKED PARTS AVAILABLE**

THERMAL-  
RIBBONS

▼ = STANDARD OPTIONS

Specifications subject to change





# Discoil™ Thermal-Ribbons

## Overview

Install these compact sensors anywhere for accurate point sensing. Discoil™ RTD elements are wound on a single plane for faster time response.

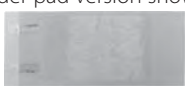
## Specifications

Dimensions W x L x T <sub>max</sub>	Element options	Insulation	Temperature range	Leadwires	Time constant*	Features	Model
0.79 x 1.87 x 0.055" (20 x 47.5 x 1.4 mm) solder pad version shown 	▼ PD PE	Polyimide (clear polyester available)	-73 to 200°C -100 to 392°F	(Optional) AWG 24, PTFE insulat- ed	0.10 sec.	Only 0.010" thick over element, fast time response, plat- inum PD accuracy available	▼ S17422
1.00 x 1.25 x 0.090" (25.4 x 31.8 x 2.3 mm) 	▼ PB11 PB22	Silicone rubber with polyimide backing	-62 to 220°C -80 to 428°F	AWG 24, silicone rubber insulated	0.2 sec.	High temperature rating, platinum PD accuracy available	▼ S32
	▼ PD12 PE22						▼ S385

Notes: T<sub>max</sub> is measured over the lead bulge.

\*Time constant is in water at 1 m/sec.

## Sensing elements

Sensing element specifications**	Code
Platinum (0.00391 TCR) 100 Ω ±0.5% at 0°C	PA
Platinum (0.00391 TCR) 100 Ω ±0.11% at 0°C	PB11
Platinum (0.00391 TCR) 100 Ω ±0.22% at 0°C	PB22
Platinum (0.00385 TCR) 100 Ω ±0.12% at 0°C (EN60751, Class B)	PD, PD12
Platinum (0.00385 TCR) 100 Ω ±0.36% at 0°C	PE (Discoil)
Platinum (0.00385 TCR) 100 Ω ±0.5% at 0°C	PE (Strip sensing)
Platinum (0.00385 TCR) 100 Ω ±0.22% at 0°C	PE22
Nickel-iron (0.00518 TCR) 604 Ω ±0.26% at 0°C	FA
Copper 427	CA
Nickel 672	NA

\*\* See table above for element options on each model.

## Specification and order options

S32	Model number from table
PB22	Sensing element from table
Z	Number of leads: ▼ Y = 2 leads ▼ Z = 3 leads X = 4 leads ▼ W = Solder pads (S17422 only)
36	Lead length in inches ▼: 0, 12, 36, 144 (Specify 0 for solder pads, option on S17422 only)
A	Adhesive backing: ▼ A = No adhesive ▼ B = Pressure-sensitive adhesive (PSA)
S32PB22Z36A = Sample part number	

Notes: PSA reduces temperature range to -20 to 177°C  
(-4 to 350°F) and adds 0.005" (0.1 mm) to thickness.



▼ = STANDARD OPTIONS  
Specifications subject to change

# Strip Sensing Thermal-Ribbons™

## Overview

These models average temperatures along their length to eliminate point measurement errors. Wrap them around cylinders or adhere them to flat surfaces.

## Specifications

Dimensions W x L x T <sub>max</sub>	Element options	Insulation	Temperature range	Lead-wires	Time constant*	Features	Model
 0.50 x 1.25 x 0.050" (12.7 x 31.8 x 1.3 mm)	▼PA ▼PE ▼CA ▼NA	Polyimide	-73 to 200°C -100 to 392°F	AWG 26, PTFE insulated	0.17 sec.	Easy motor installations	▼S3238
 0.375 x 4.00 x 0.075" (9.5 x 101.6 x 1.9 mm)	▼PB22 ▼PD12 PE22	Silicone rubber w/ polyimide backing	-62 to 220°C -80 to 428°F		0.6 sec.	Platinum PD accuracy	▼S34 ▼S386
 0.375 x 4.00 x 0.065" (9.5 x 101.6 x 1.7 mm)	▼FA	Polyimide	-200 to 200°C -328 to 392°F		0.2 sec.	Wire-wound nickel-iron for high resistance, thin element	▼S35

Notes: T<sub>max</sub> is measured over the lead bulge.

\*Time constant is in water at 1 m/sec.

Refer to Sensing Elements Table on Page 9-4

## Specification and order options

S34	Model number from table (except S3238)
PB22	Sensing element from table
Y	Number of leads: Y = 2 leads Z = 3 leads (required on CA) X = 4 leads (PD only)
36	Lead length in inches: 36" stocked
A	Adhesive backing: A = No adhesive B = Pressure-sensitive adhesive (PSA)
S34PB22Y36A = Sample part number	

Notes: PSA reduces temperature range to -20 to 177°C (-4 to 350°F) and adds 0.005" (0.1 mm) to thickness.

## Model S3238

Model S3238 is specially designed to sense **stator** temperatures in motors and generators. An alternative to the "stick" sensors, the S3238 mounts on the end turns of stator windings and provides an easy way to add overtemperature protection when the stator is not being rewound.

## S3238 specification and order options

S3238	Model number S3238
PA	Sensing element from table
Y	Number of leads: ▼Y = 2 leads (not available on CA) ▼Z = 3 leads      X = 4 leads
T	Lead insulation: ▼T = PTFE ▼TS = SS braid over PTFE
36	Lead length in inches: ▼: 36, 240
U	Lead configuration: ▼T = Twisted      ▼U = Untwisted
A	Adhesive backing: ▼A = No adhesive ▼B = Pressure-sensitive adhesive (PSA)
S3238PAYT36UA = Sample part number	



**STOCKED PARTS AVAILABLE**

THERMAL-  
RIBBONS

Note: Available up to 10 pieces or contact Minco Customer Service

▼ = STANDARD OPTIONS

Specifications subject to change



# Thermistor Thermal-Tab™

## Overview

Model TS665 and TS667 offer extremely sensitive NTC thermistors for applications with small temperature changes. Model TS667 also features waterproof construction, making it suitable for continuous immersion.

## Specifications

Dimensions W x L x T <sub>max</sub>	Element options	Insulation	Temp. range	Leadwires	Time constant	Feature	Model
0.20 x 0.47 x 0.079" (5.0 x 12.0 x 2.0 mm)	TF, TK	Polyimide with elastomer cover coat	-50 to 125°C (-58 to 257°F)	AWG 26, PTFE insulated	0.8 sec.	Small, low-cost	▼TS665
0.20 x 0.60 x 0.118" (5.0 x 15.2 x 3.0 mm)		Silicone rubber with elastomer cover and foil backing		AWG 24, Silicone insulated	1.3 sec.	Waterproof, suitable for continuous immersion	▼TS667

Notes: T<sub>max</sub> is measured over the lead bulge. TS665 is suitable for the CT325 temperature controller (page 4-20). \*Time constant is in water at 1 m/sec.

## Sensing elements

Sensing element specifications**	Code
NTC thermistor 50k Ω ±1% at 25°C	▼TF
NTC thermistor 10k Ω ±1% at 25°C	▼TK

\*\* See table above for element options on each model.

## Specification and order options

TS665	Model number from table
TF	Sensing element from table
Y	Number of leads: Y = 2 leads
40	Lead length in inches: ▼40" (60" max.)
A	Adhesive backing: ▼A = No adhesive B = Pressure-sensitive adhesive (PSA)
C	Compliance: C = RoHS compliant
TS665TFY40AC = Sample part number	

Note: PSA reduces temp. range to -20 to 177°C (-4 to 350°F) and adds 0.005" (0.1 mm) to thickness.



**STOCKED PARTS AVAILABLE**

# Thermocouple Thermal-Ribbon™

## Overview

TC40 is a patch-style thermocouple that adheres to all types of surfaces for quick and easy mounting.

## Specifications

Dimensions W x L x T <sub>max</sub>	0.75 x 0.75 x 0.065" (19.1 x 19.1 x 1.7 mm)
Junction type	E, J, K, or T
Insulation	Polyimide
Temp. range	-200 to 200°C (-328 to 392°F)
Leadwires	AWG 24, solid PTFE insulated
Time constant	0.6 sec.
Features	Surface mounting
Model	TC40

Notes: T<sub>max</sub> is measured over the lead bulge.

\*Time constant is in water at 1 m/sec.

## Specification and order options

TC40	Model number
J	Junction type: E, ▼J, ▼K, or ▼T
T	Covering over leadwires: ▼T = PTFE only S = Stainless steel braid
40	Lead length in inches: ▼: 40, 240
A	Adhesive backing: A = No adhesive B = Pressure-sensitive adhesive (PSA)
TC40JT36A = Sample part number	

Note: PSA reduces temperature range to -20 to 177°C (-4 to 350°F) and adds 0.005" (0.1 mm) to thickness.

▼ = **STANDARD OPTIONS**  
Specifications subject to change

# Thermal-Ribbon Installation and Accessories

Thermal-Ribbons lend themselves to a variety of installation methods. You should avoid repeated bending during the installation process, and Thermal-Ribbons should not flex in use unless they are specifically designed to do so. Take care to secure leadwires so they do not pull against sensor bodies. Leadwires should be routed along the sensed surface a short distance so that they do not sink heat away from the sensing element. Listed below are some standard installation methods.

## Pressure sensitive adhesive

PSA (option B in part number) is the simplest mounting method, but it is restricted to flat surfaces and temperatures below 177°C (350°F). PSA is usually factory applied to the mounting surface of the Thermal-Ribbon. To install, just remove the backing paper and press in place.

## #20 stretch tape

High temperature silicone rubber tape for mounting Thermal-Ribbons to pipes or other cylinders as shown above. It comes in 1" wide rolls, 6 or 36 feet long.



### Thermal Ribbons for pipe sensing

Thermal Ribbons make a practical, economical alternative to traditional immersed sensors for sensing fluid temperatures in pipes or tanks. They mount directly on pipe surfaces, so there is no need to tap and drain systems to install thermowells. If the Thermal-Ribbon is installed correctly, tests show that the thermal response is as quick and accurate as traditional invasive sensors. See page 8-7 for Thermal-Ribbons specially designed for pipe sensing.

## #6 RTV cement

Room temperature vulcanizing cement for mounting silicone rubber Thermal-Ribbons to flat or curved surfaces. It is available in 3 oz. (89 ml) tubes. Contact Minco for other adhesives usable with Kapton™ or Mylar™ Thermal-Ribbons.

## Shrink bands

Minco shrink bands are pre-stretched plastic strips with adhesive at both ends. Use them to mount Thermal-Ribbons to cylinders. Simply wrap the band around the sensor and cylinder, secure the ends, and heat to shrink in place. To order, specify band width and cylinder diameter.

## #21 Polyimide tape

High temperature tape with silicone-based adhesive. Useful for quick mounting of Thermal-Ribbon or Thermal-Tab sensors to flat surfaces. Makes a strong but removable bond to most smooth and clean surfaces. Maximum operating temperature is 150°C. 0.5 inch wide x 108 ft. long roll.



Minco manufactures flexible Thermofoil™ etched-foil heaters for precision temperature control of critical applications. We can integrate heaters with Thermal-Ribbons and other sensors and controllers to provide complete turnkey thermal solutions.

Learn more about Thermofoil heater solutions at [www.minco.com](http://www.minco.com)





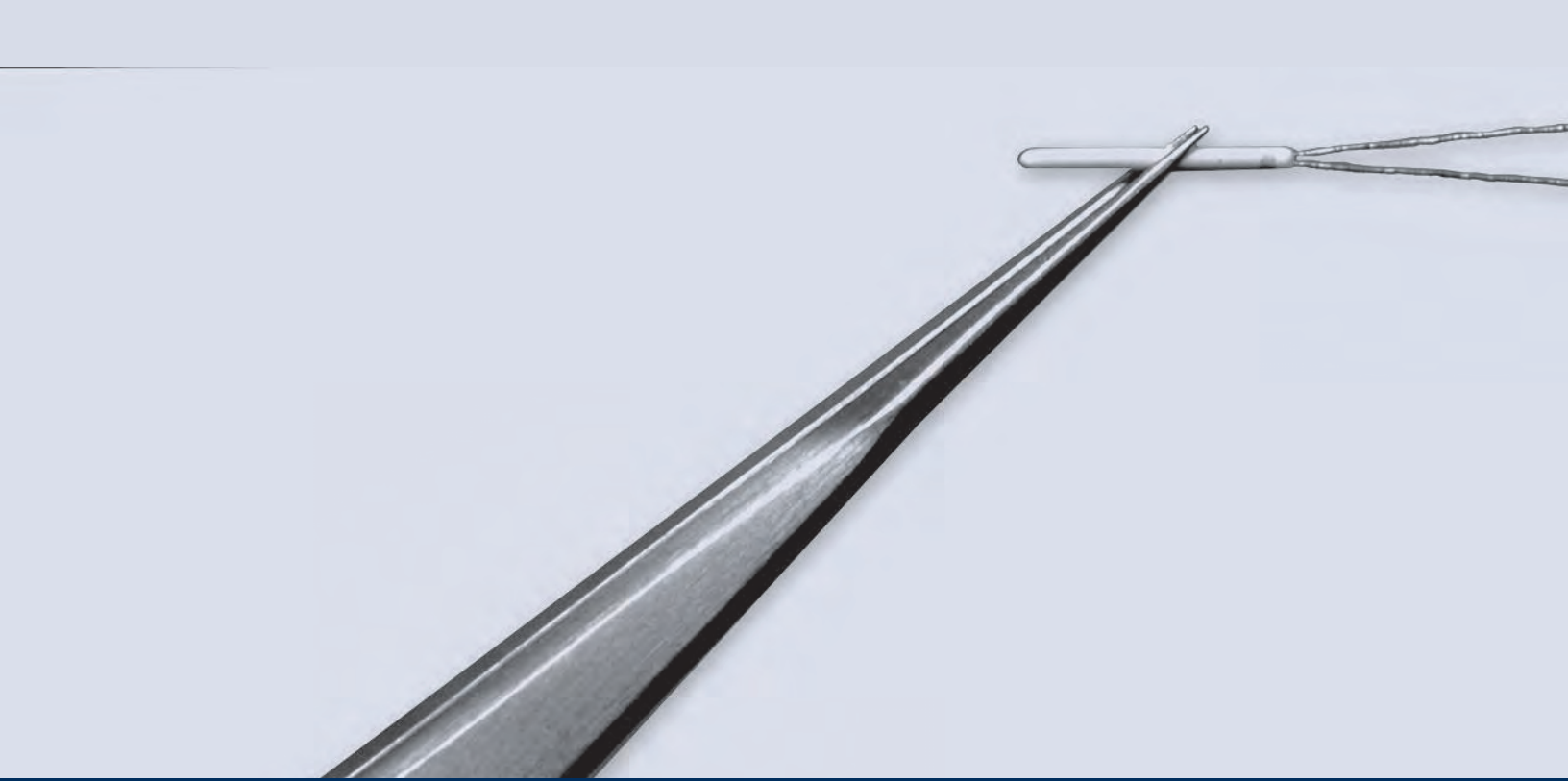

## ▶ SECTION 10: ELEMENTS

- Accurate sensing from -200 to 600°C (-328 to 1112°F)
- Wide choice of sizes and styles for application versatility
- Low cost thin-film elements
- Wire wound elements

Wire-wound elements.....	10-2
Thin-film elements .....	10-2
Installation.....	10-3
Extension leads.....	10-3

# Wire-wound & Thin-film Elements

## Overview: Wire-wound Elements

Use these elements for general purpose sensing in probes or equipment. PD models meet EN60751, Class B.

### Specifications

**Temperature range:** See table below. Some elements may be used down to -269°C in certain applications. Contact factory for advice on cryogenic use.

**Element Body:** Glass-coated ceramic

**Resistance Tolerance:** ± 0.1% at 0°C

**Lead Length Tolerance:** ± 0.4" (10.2mm)

**TCR:** 0.00385 Ω/Ω/°C

**Element Diameter tolerance:** ±0.005" (0.13 mm)

**Element Length tolerance:** ±0.06 (1.5 mm)

**Repeatability:** ±0.1°C or better

**Stability:** Drift less than 0.1°C/year (normal use)

**Vibration:** Withstands 20 G's minimum at 10 to 2,000 Hz.

**Shock:** Withstands 100G's minimum sine wave shock of 8 milliseconds duration

## Overview: Thin-film Elements

Thin film elements offer low cost and resistances to 10k Ω.

### Specifications

**Tolerance:** ±0.12% (EN60751 Class B) To order optional ±0.06% tolerance (EN60751 Class A), change 12 to 06 for ±0.06% (EN60751 Class A). Not available with S101162PD, S101163PF, or S19827PS.

**Material:** Aluminum oxide substrate with fused glass cover.

#### Dimensional tolerance:

400, 600°C elements: ±0.02" (0.5 mm).

SMT models: Length x Width ±0.008 (0.2 mm),

Thickness ±0.004 (0.1 mm).

**TCR:** 0.00385 Ω/Ω/°C.







**Repeatability:** ±0.1°C or better.

**Stability:** Drift less than 0.1°C/year in normal use.

**Vibration:** Withstands 20 G's minimum at 10 to 2,000 Hz.

**Shock:** Withstands 100 G's minimum sine wave shock of 8 milliseconds duration.

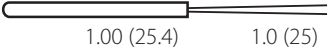
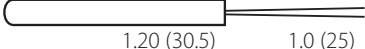
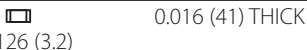
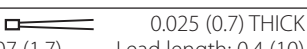
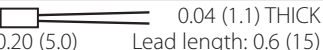
### Order options: order part number from table.

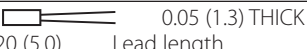
Dimensions in inches (mm)	R (0°C)	Temp. range	Leads	Model
<b>550°C wire-wound elements</b>				
0.040 ø (1.020) 	100 Ω	-20 to 550°C (-4 to 1022°F)	0.006" (0.15 mm) ø Platinum	▼ S200PD
0.058 ø (1.47) 			0.010" (0.25 mm) ø Platinum clad palladium	▼ S201PD
0.077 ø (1.96) 			▼ S202PD	
0.100 ø (2.54) 			▼ S203PD	
0.135 ø (3.43) 			S204PD	
0.077 ø (1.96) 			▼ S212PG	
0.135 ø (3.43) 			▼ S214PG	
<b>400°C and 600°C thin-film elements</b>				
0.063 (1.6)  0.126 (3.2) 0.016 (41) THICK	100 Ω	-50 to 150°C (-58 to 302°F) SMT (surface mount technology)	Solder contacts: Tin plated, 0.020" (.51 mm)	▼ S101162PD
	1000 Ω			▼ S101163PF
0.05 (1.3)  0.07 (1.7) 0.025 (0.7) THICK Lead length: 0.4 (10)	100 Ω	-50 to 400°C (-58 to 752°F)	0.010" (0.25 mm) ø Ag .0004 Ω / mm / lead	▼ S100144PD12
	1000 Ω			▼ S101503PF12
0.10 (2.5)  0.20 (5.0) 0.04 (1.1) THICK Lead length: 0.6 (15)	10000 Ω	-70 to 400°C (-94 to 752°F)	0.010" (0.25 mm) ø Ag .0004 Ω / mm / lead	▼ S19827PS12
	100 Ω			▼ S245PD12
0.08 (2.0)  0.09 (2.3) 0.05 (1.3) THICK Lead length S245: 0.6 (15) S249: 0.4 (10)	100 Ω	-70 to 600°C (-94 to 1112°F)	0.008" (0.20 mm) ø Pt/Ni .003 Ω / mm / lead	▼ S249PD12
	1000 Ω	-70 to 400°C (-94 to 752°F)	0.010" (0.25 mm) ø Ag .0004 Ω / mm / lead	▼ S247PF12
0.08 (2.0)  0.20 (5.0) 0.05 (1.3) THICK Lead length S247: 0.6 (15) S251: 0.4 (10)	1000 Ω	-70 to 600°C (-94 to 1112°F)	0.008" (0.20 mm) ø Pt/Ni .003 Ω / mm / lead	▼ S251PF12

Note: Contact Minco Customer Service for quantities available

Specifications subject to change

# Installation & Accessories

## Installation

Ceramic elements can be assembled into probes or potted inside holes in heat sinks and platens. Ceramic cement is recommended for high temperature potting. Epoxy is recommended for intermediate temperatures.

Round elements provide the best time response in round sheaths and holes. Flat thin film elements can be bonded to surfaces.

Elements are calibrated at the end of their leads. The leads have resistances ranging from 0.6 to 2.4  $\Omega$  per foot, so you should connect extension leads as close as possible to the end of the element leads to maintain tolerance.

Minco can supply elements with extension leadwires welded onto the sensor leads. Use the standard models below or contact us for a quote on your custom design.

One final note: Ceramic elements are fragile and can suffer damage or loss of accuracy from improper installation. In many cases, the best alternative is to buy a complete encased probe assembly from Minco. Take advantage of our expertise and equipment for best overall performance and value.

### #8 high temperature cement

#8 comes as a powder in 1 oz. packages. Just add water to form a potting compound rated to 850°C (1562°F).



Extension leads

## Extension leads

All elements are available with factory-welded extension leads insulated with PTFE, polyimide, or mica/glass.

### Model AC887

**Insulation:** PTFE, FEP tubing over connections

**Maximum temperature:** 200°C (392°F).

Lead AWG	Maximum diameter over lead bundle in inches (mm)		
	2 leads	3 leads	4 leads
22	0.15 (3.8)	0.16 (4.0)	0.18 (4.6)
24	0.14 (3.5)	0.14 (3.5)	0.17 (4.3)
26	0.13 (3.3)	0.14 (3.5)	0.14 (3.5)
28	0.13 (3.3)	0.13 (3.3)	0.13 (3.3)
30	0.11 (2.8)	0.12 (3.0)	0.12 (3.0)

### Model AC888

**Insulation:** Mica/glass, glass braid over connections

**Maximum temperature:** 550°C (1022°F).

Lead AWG	Maximum diameter over lead bundle in inches (mm)		
	2 leads	3 leads	4 leads
22	0.16 (4.0)	0.20 (5.1)	0.20 (5.1)

### Model AC889

**Insulation:** Polyimide, FEP tubing over connections

**Maximum temperature:** 200°C (392°F).

Lead AWG	Maximum diameter over lead bundle in inches (mm)		
	2 leads	3 leads	4 leads
22	0.14 (3.5)	0.16 (4.0)	0.17 (4.3)
26	0.13 (3.3)	0.15 (3.8)	0.15 (3.8)
30	0.11 (2.8)	0.12 (3.0)	0.12 (3.0)

### Model AC101828

**Insulation:** Glass braid, glass braid over connections

**Maximum temperature:** 550°C (1022°F).

Lead AWG	Maximum diameter over lead bundle in inches (mm)		
	2 leads	3 leads	4 leads
27 solid leads	0.10 (2.5)	0.12 (3.0)	0.13 (3.3)

## Extension lead specification and order options

AC887	Model number
Z	Number of leads: Y = 2 leads Z = 3 leads X = 4 leads
26	Lead gauge (AWG)
L	
48	Lead length in inches
AC887Z26L48 = Sample part number	

▼ = **STANDARD OPTIONS**  
Specifications subject to change



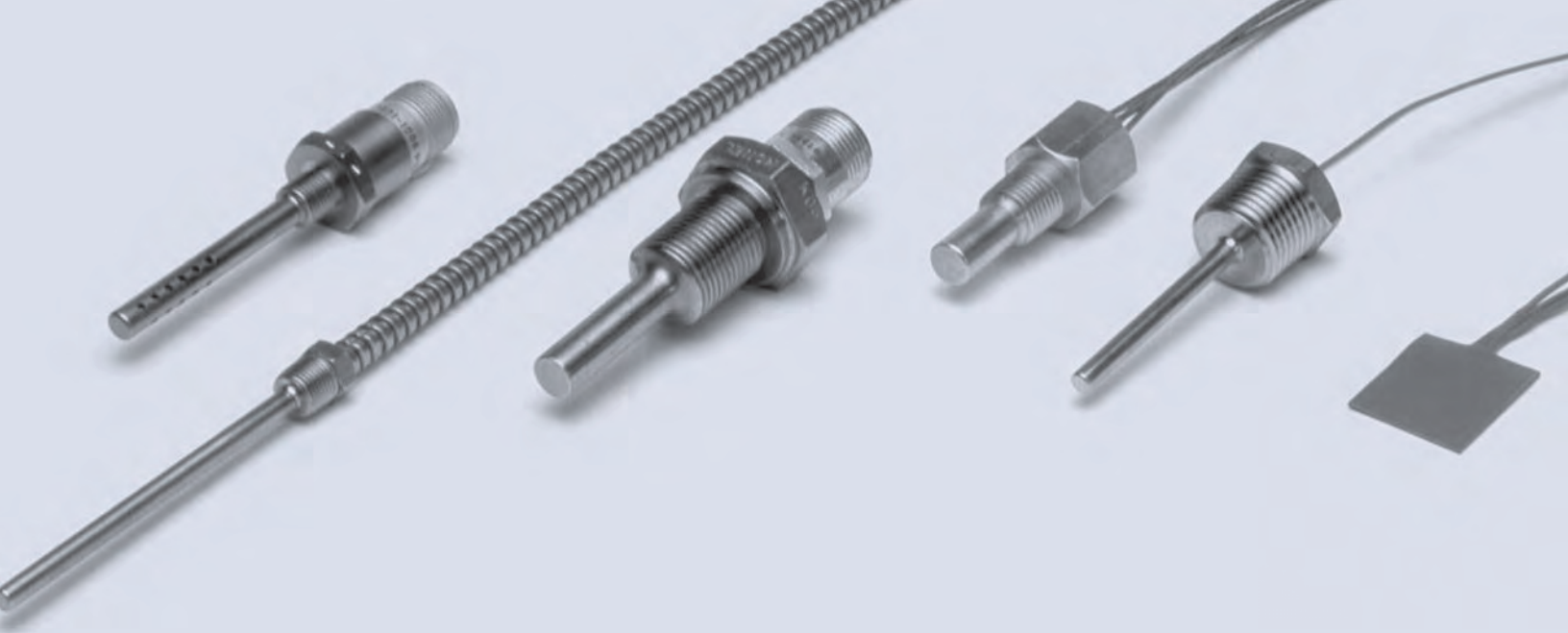

## ► SECTION 11: TECHNICAL INFORMATION

Your product guide.....	11-2
Many industry applications.....	11-3
Designed for optimal performance.....	11-4 to 11-5
Temptran™ temperature transmitters.....	11-6
RTD, thermocouple, or thermistor?.....	11-7
Choosing sensor elements.....	11-8
RTD connections: 2-wire, 3-wire, 4-wire?.....	11-9
Resistance/temperature tables.....	11-10 to 11-11
Thermocouple voltage/temperature tables.....	11-11
Temperature coefficient of resistance (TCR).....	11-12
SensorCalc program.....	11-12
Miscellaneous specifications and codes.....	11-12
Material selection guide.....	11-13

# Your Sensors & Instruments Product Guide

---

## How To Get Started

### 1. Understand and define your application requirements

Many factors should be a part of the sensor system design process. The factors listed below can help you define the sensing requirements for your application.

Define the typical and extremes of these environmental conditions:

- minimum and maximum temperatures
- pressure
- humidity
- shock
- vibration
- flow rate

Also ask:

- What is the sensed medium (a surface or immersed in solid, liquid or gas)?
- Is the medium chemically reactive (corrosive) or hazardous (explosive)?
- Is there high electromagnetic interference potential from power switching, rectification, or radio waves?

Finally, define the significance of these performance specifications in your application?

- sensing accuracy at a calibration point and/or over a temperature span
- repeatability
- stability
- sensor time constant
- insulation resistance

### 2. Determine which sensing technology options meet your requirements

Several potential sensing technologies may meet the essential environmental and performance specifications of your application. This section of the *Sensors and Instruments Product Guide* will provide you with a basic understanding of Minco's sensing and instrumentation technology. For more information go to [www.minco.com](http://www.minco.com).



### 3. Compare sensor construction alternatives for best fit and ease of use

While a sensing technology may appear to be capable of meeting the requirements of your application, the actual sensor packaging and construction must be evaluated in order to select the optimal cost/performance balance from the available technology options.

Regardless of which sensing technology you consider, the packaging of the sensor introduces some level of specification compromise in terms of cost, performance or durability. Use this guide to compare Minco's various sensor constructions and instrumentation solutions to find the best fit for your application.

### 4. Obtain parts for testing as prototypes in your application

Minco has a wide selection of standard sensor components that can often be used for prototype testing and production systems. We would appreciate the opportunity to discuss your application with you. We can help ensure that the right sensor construction is selected for your application as well as any accessory components. Often times, we are able to offer recommendations for customization to improve performance and/or lower installed cost.

Order sensors and instruments easily online with our Sensors Configurator at [www.minco.com](http://www.minco.com) or contact Minco Sales and Customer Service today to talk to an engineer about your application.

# Many Industry Applications

## Process Control and Building Automation

Minco temperature and humidity sensors and instruments are used in process and HVAC/R applications in the most critical environments. Our sensing solutions achieve the lowest total cost of ownership (TCO) while maintaining accuracy, reliability and ease of installation.



The Thermal-Vial Temperature Sensing System encompasses a wire-wound RTD element capable of -200°C operation to provide accurate measurement and documentation of freezing, process and storage methodology.

## Machinery and Motor Protection

Minco RTDs and Thermocouples are used worldwide to safeguard valuable rotating apparatus machinery. Accurate and fast-responding temperature measurement provides overtemperature protection, and our sensors can be manufactured to integrate with any instrumentation package.

Bearing and stator sensors provide accurate sensing in this motor component while Minco's 12-channel temperature monitor (CT224) provides easy and efficient thermal protection.



## Defense and Aerospace

Minco temperature sensors are used when ruggedness and reliability are key to an applications success. Our sensors can be manufactured to fit in the smallest spaces or across wide expanses. Fast time response and wide temperature capabilities (from -260°C to 650°C) handle nearly any type of harsh or extreme environment.

RTDs monitor the temperature of a heated windshield.



Flexible Thermal-Ribbons sense wing surface temperatures for wing surface de-icing.

Temperature sensors in hydraulic lines monitor fluid temperatures to prevent overheating.

## Industrial and Commercial Equipment

Minco products are manufactured to provide dependability and repeatability in any application. Our sensors and instruments are used in industrial and commercial equipment to ensure accurate process and quality output.

Fast response RTDs monitor oil temperature for perfect cooking results.



# Designed for Optimal Performance

Minco offers the perfect fit for any temperature and humidity sensing application. From miniature detectors to 100 foot averaging thermometer and heavy duty probe assemblies, our selection lets you choose the best model for your needs.



## Sensing technology options provide flexibility

Minco can supply sensors to work with nearly any type of instrument option.

- Resistance Temperature Detectors (RTDs)
  - Platinum RTDs with wide range of TCRs
    - Range from 0.00375 to 0.003927
    - 0.00385 (Minco element "PD") is most popular
  - Nickel, copper, and nickel-iron RTD elements
  - Non-standard resistance-temperature curves
  - Base resistances up to thousands of ohms
  - Thin film or wire wound constructions
- Thermistor temperature sensors
- Thermocouple temperature sensors
- Integrated Circuit temperature sensors
- High accuracy humidity sensors and transmitters
- Signal conditioning
  - Linearizing transmitters with 4 to 20 mA, 1 to 5 VDC or other voltage/current outputs, and HART® Protocol
- Explosionproof temperature and humidity sensor and transmitter assemblies
- Controllers, monitors and alarms for optimal compatibility with sensors

## From simple elements to complex assemblies

Minco can configure a sensor style to best fit your application and capabilities:

- Basic sensing elements for assembly into your own housing or protective sheath
- Addition of leadwires and terminations to elements
- Packaging into protective sheaths, laminates, custom housings, cabling
- Bendable case designs or preformed to your specifications
- Assembly with fittings, connection heads, thermowells, connectors, feedthroughs

- Assembly with signal conditioning electronics, standard or customized
- Certified measurement and test in our metrology lab
- Certified designs for hazardous locations

## Machining and materials

A sensor's construction has a large impact on its thermal time response and resistance to corrosive media. Minco has an advanced machine shop with CAD/CAM capability for economic production of cases and fittings.

We have extensive machining capabilities in a variety of materials:

- Stainless steel in various grades
- Copper
- Hastelloy
- Rubber, PTFE, plastics
- Brass
- Monel
- Titanium

We can plate with nickel, gold, and other metals. Additional services include electro-polishing, passivating, and pressure testing.

## Leadwires

Sensors may be furnished with many different types of leadwire and cables to meet application parameters:

- PTFE, silicone rubber, polyimide, Tefzel, PVC, mica/glass, and glass braid insulation over silver or nickel plated copper wire are common selections or specify your own leadwire or cable requirements
- Stainless steel overbraid or flexible armor
- Flat ribbon leads or sensor/flex circuit hybrids



## Lamination

Minco's winding and lamination technology enables manufacture of flat, flexible sensors in any size or shape. The custom Thermal-Ribbon™ below has a wire element to average temperatures over its entire area.

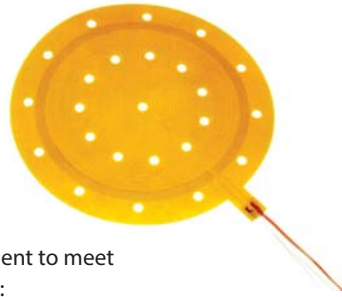

## Testing

Minco has complete in-house testing and metrology equipment to meet stringent quality requirements:

- NIST traceable calibrations
- Hydrostatic testing of thermowells
- Helium leak testing
- Automated resistance measurement
- Humidity testing

## Designing for accuracy

How accurate is a temperature sensor? To many, the answer to this question is the sensor's interchangeability specification. For example, 100  $\Omega$  platinum RTDs are typically interchangeable within 0.1  $\Omega$  (0.3°C) at 0°C.

But interchangeability only tells how closely the electrical characteristics of a sensor conform to its published tables. What you really want to know is how much the temperature seen at your readout or controller deviates from the actual temperature of the material you are sensing. Interchangeability is only one of the potential sources of error in the system, and it is usually not the largest. Following are some other error modes along with suggested solutions.

**Repeatability/stability:** Repeatability tells how well the sensor repeats subsequent readings at the same temperature. Stability is the absence of long term drift. In many cases, the user is less concerned with absolute accuracy than with the ability of a sensor to maintain a process at the same point once properly set.

**Solution:** Platinum RTDs are the most stable sensor in common use and are used to interpolate over the standard temperature scale from -260 to 962°C. Ordinary industrial models will drift less than 0.1°C per year in normal use.

**Time lag:** When temperatures change rapidly, sensors may not keep up.

**Solution:** Minco specializes in fast response RTDs. Most models in this guide have a time constant of 2 seconds or less. Certain custom-designed models are faster yet.

Time constant is defined as the time it takes a sensor to reflect 63% of a step temperature change:

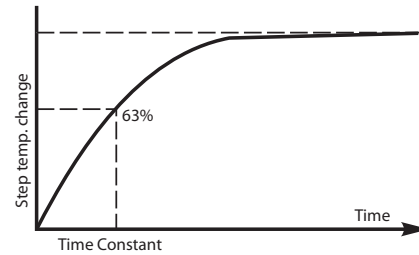

**Conduction errors:** Heat conducted into sensors from ambient air alters the temperature of the sensing tip.

**Solution:** Use smaller sensors or tip-sensitive probes, and be sure they are sufficiently immersed or embedded in the sensed medium.

**Point sensing errors:** In places where temperatures are stratified or gradients are large, the temperature at a single point may be unrepresentative or misleading.

**Solution:** Use temperature averaging probes or Thermal-Ribbons.

**Leadwire resistance:** Resistance in the leads between RTDs and control points elevates apparent readings.

### Solutions:

- Specify sensors with higher resistances.
- Use 3 or 4-wire compensating circuits (see page 11-9).
- Eliminate leadwire effects with a 4 to 20 mA transmitter.

**Self-heating:** The measuring current through an RTD can raise its temperature above the true value.

**Solution:** As a general rule, limit current to 5 mA for industrial applications. Most Minco RTDs, and especially Thermal-Ribbons, have a large surface area to dissipate heat and reduce self-heating effects.

## Custom designs

If you have special requirements - or an OEM design - Minco can typically manufacture a custom sensor solution to improve accuracy and reduce cost at the same time. Contact Minco Sales and Customer Service today to discuss your application.

# Temptran™ Transmitter Solutions

---



## Why use Temptrans?

### Long distance accuracy

Temptran transmitters amplify the low-level signals from RTDs or thermocouples to an industry-standard 4 to 20 mA current signal proportional to temperature or HART® Protocol/output. Unlike resistance or voltage, current signals are immune to resistance in extension wires and stray electrical noise. This lets you receive accurate signals from a sensor located thousands of feet away.

The 4 to 20 mA or HART® output signal and DC power share the same wire pair. You don't need to run power wires to every sensor location. In fact, using HART® transmitters configured in multidrop mode, up to 15 transmitters can be connected in parallel on the same pair of wires.

RTD transmitters also linearize the signal to temperature, making them excellent low cost signal conditioners. Their signal increases from 4mA at the lowest temperature to 20mA at the highest temperatures.

### Engineered for reliability

Over 500,000 Minco transmitters are currently giving trouble-free service in installations around the world. Two factors behind Temptran's exceptional stability and longevity are:

- Minco encapsulates all electronics in epoxy to exclude contaminants and protect components.
- Standard fixed-range transmitters feature  $\pm 5\%$  adjustability using 20 turn trimpots. Because a complete rotation of the trimpot represents only 0.25% of the adjustment range, slight movements from mechanical shock cause only negligible output change. In contrast, many competitive transmitters have wide ranging zero and span. With zero and span far more sensitive to potentiometer shifts, a minor bump can void the transmitter's calibration.

**See Section 4 for complete details and ordering information.**

### Easy to install

Compact Temptrans fit nearly anywhere. You can install most models in standard electrical utility boxes and elbows. Or Minco offers a complete selection of complementary connection heads in Section 3.

### Intrinsic safety

Most Temptrans are rated intrinsically safe by Factory Mutual (FM), a recognized testing authority for safety in hazardous areas. Division 1 installations must include a suitable barrier. Go to [www.minco.com](http://www.minco.com) for a list of barriers FM approved under the system concept for use with Temptrans.

### Special high-accuracy calibration

Standard transmitters can be calibrated to the nominal resistance values of the RTD at the zero and span points. Total system error includes the tolerance of both the transmitter and the RTD sensor. If you order Minco Temptrans match calibrated to the actual resistance of the RTD (traceable to NIST), this effectively eliminates the sensor tolerance from the system accuracy specifications.

Temptrans match calibrated to a sensor are always ordered as assemblies. Common examples are shown in Section 1.

For example, consider a transmitter with a range of 0 to 500°C. The transmitter itself is accurate to  $\pm 1.0^\circ\text{C}$  ( $\pm 0.2\%$  of span, including calibration accuracy and linearity). The RTD interchangeability contributes an additional error of  $\pm 0.3^\circ\text{C}$  at 0°C and  $\pm 2.8^\circ\text{C}$  at 500°C. Total system error would be  $\pm 1.3^\circ\text{C}$  at 0°C and  $\pm 3.8^\circ\text{C}$  at 500°C. Calibration of the sensor and transmitter as a set cancels the sensor error, reducing system error to  $\pm 1.0^\circ\text{C}$  over the full range — all for a nominal extra cost. Get more information on page 4-22.

# RTD, Thermocouple, or Thermistor?

## Resistance temperature detectors (RTDs)

An RTD sensing element consists of a wire coil or deposited film of pure metal. The element's resistance increases with temperature in a known and repeatable manner. RTDs exhibit excellent accuracy over a wide temperature range and represent the fastest growing segment among industrial temperature sensors. Their advantages include:

- **Temperature range:** Minco models cover temperatures from -260 to 650°C (-436 to 1202°F).
- **Repeatability and stability:** The platinum resistance thermometer is the primary interpolation instrument used by the National Institute of Standards and Technology from -260 to 962°C. Ordinary industrial RTDs typically drift less than 0.1°C/year.
- **Sensitivity:** The voltage drop across an RTD provides a much larger output than a thermocouple.
- **Linearity:** Platinum and copper RTDs produce a more linear response than thermocouples or thermistors. RTD non-linearities can be corrected through proper design of resistive bridge networks.
- **Low system cost:** RTDs use ordinary copper extension leads and require no cold junction compensation.
- **Standardization:** Manufacturers offer RTDs to industry standard curves, most commonly 100 Ω platinum to EN60751 (Minco element code PD or PM).

## Thermocouples

A thermocouple consists of two wires of dissimilar metals welded together into a junction. At the other end of the signal wires, usually as part of the input instrument, is another junction called the reference junction, which is electronically compensated for its ambient temperature. Heating the sensing junction generates a thermoelectric potential (emf) proportional to the temperature difference between the two junctions. This millivolt-level emf, when compensated for the known temperature of the reference junction, indicates the temperature at the sensing tip.

Thermocouples are simple and familiar. Designing them into systems, however, is complicated by the need for special extension wires and reference junction compensation. Thermocouple advantages include:

- **Extremely high temperature capability:** Thermocouples with precious metal junctions may be rated as high as 1800°C (3272°F).

- **Ruggedness:** The inherent simplicity of thermocouples makes them resistant to shock and vibration.
- **Small size/fast response:** A fine-wire thermocouple junction takes up little space and has low mass, making it suitable for point sensing and fast response. Note, however, that many Minco RTDs have time constants faster than equivalent thermocouples.

## Thermistors

A thermistor is a resistive device composed of metal oxides formed into a bead and encapsulated in epoxy or glass. A typical thermistor shows a large negative temperature coefficient. Resistance drops dramatically and non-linearly with temperature. Sensitivity is many times that of RTDs but useful temperature range is limited. Some manufacturers offer thermistors with positive coefficients. Linearized models are also available.

There are wide variations of performance and price between thermistors from different sources. Typical benefits are:

- **Low sensor cost:** Basic thermistors are quite inexpensive. However, models with tighter interchangeability or extended temperature ranges often cost more than RTDs.
- **High sensitivity:** A thermistor may change resistance by tens of ohms per degree temperature change, versus a fraction of an ohm for RTDs.
- **Point sensing:** A thermistor bead can be made the size of a pin head for small area sensing.

	RTD	Thermocouple	Thermistor
Temp. range	-260 to 850°C (-436 to 1562°F)	-270 to 1800°C (-454 to 3272°F)	-80 to 150°C (-112 to 302°F) (typical)
Sensor cost	Moderate	Low	Low
System cost	Moderate	High	Moderate
Stability	Best	Low	Moderate
Sensitivity	Moderate	Low	Best
Linearity	Best	Moderate	Poor
Specify for:	<ul style="list-style-type: none"> <li>• General purpose sensing</li> <li>• Highest accuracy</li> <li>• Temperature averaging</li> </ul>	<ul style="list-style-type: none"> <li>• Highest temperatures</li> </ul>	<ul style="list-style-type: none"> <li>• Best sensitivity</li> <li>• Narrow ranges (e.g. medical)</li> <li>• Point sensing</li> </ul>

# Choosing Sensor Elements

## RTD element types

Platinum is the most widely specified RTD element type due to its wide temperature range, stability, and standardization between manufacturers. Copper, nickel, and nickel-iron can offer comparable accuracy at lower cost in many applications.

Element material	Temperature range	Benefits	Typical base resistance	Sensitivity (Avg. $\Omega/^\circ\text{C}$ , 0 to 100 $^\circ\text{C}$ )	TCR $\Omega/\Omega/^\circ\text{C}$
Platinum	-260 to 650 $^\circ\text{C}$ (-436 to 1202 $^\circ\text{F}$ )	<ul style="list-style-type: none"> <li>• Greatest range</li> <li>• Best stability</li> <li>• Good linearity</li> </ul>	100 $\Omega$ at 0 $^\circ\text{C}$ 1000 $\Omega$ at 0 $^\circ\text{C}$	0.39 3.90	0.00375 to 0.003927
Copper	-100 to 260 $^\circ\text{C}$ (-148 to 500 $^\circ\text{F}$ )	<ul style="list-style-type: none"> <li>• Best linearity</li> </ul>	10 $\Omega$ at 25 $^\circ\text{C}$	0.04	0.00427
Nickel	-100 to 260 $^\circ\text{C}$ (-148 to 500 $^\circ\text{F}$ )	<ul style="list-style-type: none"> <li>• Low cost</li> <li>• High sensitivity</li> </ul>	100 $\Omega$ at 0 $^\circ\text{C}$ 120 $\Omega$ at 0 $^\circ\text{C}$	0.62 0.81	0.00618 0.00672
Nickel-iron	-100 to 204 $^\circ\text{C}$ (-148 to 400 $^\circ\text{F}$ )	<ul style="list-style-type: none"> <li>• Low cost</li> <li>• Highest sensitivity</li> </ul>	604 $\Omega$ at 0 $^\circ\text{C}$ 1000 $\Omega$ at 70 $^\circ\text{F}$ 2000 $\Omega$ at 70 $^\circ\text{F}$	3.13 4.79 9.58	0.00518 to 0.00527

## RTD and thermistor interchangeability

The tables below show temperature tolerance — the allowable deviation from nominal curves — for RTDs and thermistors in this guide. Minco can supply sensors with tighter overall tolerance, or with the narrowest tolerance at a point other than 0 $^\circ\text{C}$ .

Temperature $^\circ\text{C}$	Interchangeability						
	Platinum RTD						
	0.06% at 0 $^\circ\text{C}$ (Class A)	0.1% at 0 $^\circ\text{C}$ (Class B)	0.22% at 0 $^\circ\text{C}$	0.36% at 0 $^\circ\text{C}$	0.5% at 0 $^\circ\text{C}$	0.1% at 70 $^\circ\text{F}$	0.24% at 70 $^\circ\text{F}$
-200	$\pm 0.55^\circ\text{C}$	$\pm 1.3^\circ\text{C}$			$\pm 2.1^\circ\text{C}$		
-100	$\pm 0.35^\circ\text{C}$	$\pm 0.8^\circ\text{C}$	$\pm 1.3^\circ\text{C}$		$\pm 1.7^\circ\text{C}$		
0	$\pm 0.15^\circ\text{C}$	$\pm 0.3^\circ\text{C}$	$\pm 0.5^\circ\text{C}$	$\pm 0.9^\circ\text{C}$	$\pm 1.3^\circ\text{C}$	$\pm 0.3^\circ\text{C}$	$\pm 0.7^\circ\text{C}$
20	$\pm 0.19^\circ\text{C}$	$\pm 0.4^\circ\text{C}$	$\pm 0.7^\circ\text{C}$	$\pm 1.3^\circ\text{C}$	$\pm 1.6^\circ\text{C}$	$\pm 0.3^\circ\text{C}$	$\pm 0.6^\circ\text{C}$
100	$\pm 0.35^\circ\text{C}$	$\pm 0.8^\circ\text{C}$	$\pm 1.8^\circ\text{C}$	$\pm 2.3^\circ\text{C}$	$\pm 2.9^\circ\text{C}$	$\pm 0.7^\circ\text{C}$	$\pm 1.1^\circ\text{C}$
200	$\pm 0.55^\circ\text{C}$	$\pm 1.3^\circ\text{C}$	$\pm 3.1^\circ\text{C}$	$\pm 3.7^\circ\text{C}$	$\pm 4.4^\circ\text{C}$	$\pm 1.3^\circ\text{C}$	$\pm 1.8^\circ\text{C}$
260	$\pm 0.67^\circ\text{C}$	$\pm 1.6^\circ\text{C}$	$\pm 3.7^\circ\text{C}$	$\pm 4.6^\circ\text{C}$	$\pm 5.5^\circ\text{C}$		
300	$\pm 0.75^\circ\text{C}$	$\pm 1.8^\circ\text{C}$					
400	$\pm 0.95^\circ\text{C}$	$\pm 2.3^\circ\text{C}$					
500	$\pm 1.15^\circ\text{C}$	$\pm 2.8^\circ\text{C}$					
600	$\pm 1.35^\circ\text{C}$	$\pm 3.3^\circ\text{C}$					
700		$\pm 3.8^\circ\text{C}$					
800		$\pm 4.3^\circ\text{C}$					
850		$\pm 4.6^\circ\text{C}$					

Temperature $^\circ\text{C}$	Interchangeability									
	Copper RTD		Nickel RTD		Nickel-iron RTD				Thermistor	
	$\pm 0.2\%$ at 25 $^\circ\text{C}$	$\pm 0.5\%$ at 25 $^\circ\text{C}$	$\pm 0.3\%$ at 25 $^\circ\text{C}$	$\pm 0.5\%$ at 0 $^\circ\text{C}$	$\pm 0.26\%$ at 0 $^\circ\text{C}$	$\pm 0.5\%$ at 0 $^\circ\text{C}$	$\pm 0.5\%$ at 25 $^\circ\text{C}$	$\pm 0.12\%$ at 70 $^\circ\text{F}$	$\pm 0.25\%$ at 70 $^\circ\text{F}$	$\pm 0.1\%$ at 0 $^\circ\text{C}$
-100	$\pm 1.5^\circ\text{C}$	$\pm 2.2^\circ\text{C}$				$\pm 2.5^\circ\text{C}$	$\pm 2.9^\circ\text{C}$			
0	$\pm 0.7^\circ\text{C}$	$\pm 1.5^\circ\text{C}$	$\pm 0.5^\circ\text{C}$	$\pm 0.8^\circ\text{C}$	$\pm 0.6^\circ\text{C}$	$\pm 1.1^\circ\text{C}$	$\pm 1.4^\circ\text{C}$	$\pm 0.5^\circ\text{C}$	$\pm 1.4^\circ\text{C}$	$\pm 0.2^\circ\text{C}$
20	$\pm 0.5^\circ\text{C}$	$\pm 1.3^\circ\text{C}$	$\pm 0.8^\circ\text{C}$	$\pm 1.2^\circ\text{C}$	$\pm 0.8^\circ\text{C}$	$\pm 1.4^\circ\text{C}$	$\pm 1.2^\circ\text{C}$	$\pm 0.3^\circ\text{C}$	$\pm 0.7^\circ\text{C}$	$\pm 0.2^\circ\text{C}$
100	$\pm 1.5^\circ\text{C}$	$\pm 2.5^\circ\text{C}$	$\pm 1.8^\circ\text{C}$	$\pm 2.2^\circ\text{C}$	$\pm 1.7^\circ\text{C}$	$\pm 2.4^\circ\text{C}$	$\pm 2.2^\circ\text{C}$	$\pm 1.1^\circ\text{C}$	$\pm 2.0^\circ\text{C}$	$\pm 0.3^\circ\text{C}$
150	$\pm 2.2^\circ\text{C}$	$\pm 3.3^\circ\text{C}$	$\pm 2.5^\circ\text{C}$	$\pm 3.0^\circ\text{C}$	$\pm 2.3^\circ\text{C}$	$\pm 3.1^\circ\text{C}$	$\pm 2.9^\circ\text{C}$	$\pm 1.6^\circ\text{C}$	$\pm 2.9^\circ\text{C}$	$\pm 1.0^\circ\text{C}$
200	$\pm 2.8^\circ\text{C}$	$\pm 4.1^\circ\text{C}$	$\pm 3.1^\circ\text{C}$	$\pm 3.7^\circ\text{C}$	$\pm 2.9^\circ\text{C}$	$\pm 3.8^\circ\text{C}$	$\pm 3.6^\circ\text{C}$	$\pm 2.1^\circ\text{C}$	$\pm 3.8^\circ\text{C}$	
260	$\pm 3.6^\circ\text{C}$	$\pm 5.1^\circ\text{C}$	$\pm 3.4^\circ\text{C}$	$\pm 4.0^\circ\text{C}$						

## Thermocouple limits of error per NBS (NIST) Monograph 175, based on ITS-90

Junction type:	E (Chromel-Constantan)	J (Iron-Constantan)	K (Chromel-Alumel)	T (Copper-Constantan)
Limits of error:	$\pm 1.7^\circ\text{C}$ or $\pm 0.5\%$ 0 to 900 $^\circ\text{C}$	$\pm 2.2^\circ\text{C}$ or $\pm 0.75\%$ 0 to 750 $^\circ\text{C}$	$\pm 2.2^\circ\text{C}$ or $\pm 0.75\%$ 0 to 1250 $^\circ\text{C}$	$\pm 1.0^\circ\text{C}$ or $\pm 0.75\%$ 0 to 350 $^\circ\text{C}$

# RTD Connections: 2-Wire, 3-Wire, 4-Wire?

Because an RTD is a resistance type sensor, resistance introduced by connecting copper extension wires between the RTD and control instrument will add to readings. Furthermore, this additional resistance is not constant but increases with ambient temperature. To estimate leadwire error in 2-wire circuits, multiply the total length of the extension leads times the resistance per foot in the table below. Then divide by the sensitivity of the RTD, given in the next two pages, to obtain an error figure in °C. For example, assume you have connected 100 feet of AWG 22 wires to a 100 Ω platinum RTD (PD element). Lead resistance is:

$$R = (200 \text{ ft.}) \times (0.0165 \text{ } \Omega / \text{ft.}) = 3.3 \text{ } \Omega$$

Approximate error is:

$$E = \frac{3.3 \text{ } \Omega}{0.385 \text{ } \Omega / \text{ } ^\circ\text{C}} = 8.6 \text{ } ^\circ\text{C}$$

Copper Leadwire AWG	Ohms/ft. at 25°C
12	0.0016
14	0.0026
16	0.0041
18	0.0065
20	0.0103
22	0.0165
24	0.0262
26	0.0418
28	0.0666
30	0.1058

You can reduce leadwire error by:

- Using larger gauge extension wires.
- Specifying an RTD with greater sensitivity; 1000 Ω instead of 100 Ω, for example.
- Employing a 3 or 4-wire resistance canceling circuit as shown at right. Common leads, connected to the same end of the sensing element, are the same color.
- Using a 2-wire current transmitter. Its linearized signal is immune to electrical noise as well as resistance and can maintain accuracy over runs of several thousand feet. See Section 4 for more information on temperature transmitters.

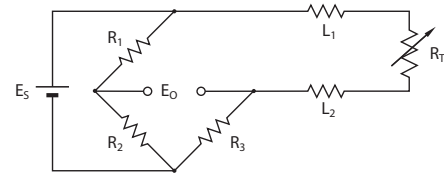

## 2-wire circuit

Shown above is a 2-wire RTD connected to a typical Wheatstone bridge circuit.  $E_5$  is the supply voltage;  $E_0$  is the output voltage;  $R_1$ ,  $R_2$ , and  $R_3$  are fixed resistors; and  $R_T$  is the RTD. In this uncompensated circuit, lead resistances  $L_1$  and  $L_2$  add directly to  $R_T$ .

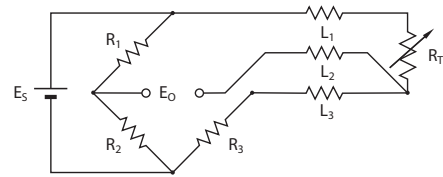

## 3-wire circuit

In this circuit there are three leads coming from the RTD instead of two.  $L_1$  and  $L_3$  carry the measuring current while  $L_2$  acts only as a potential lead. No current flows through it while the bridge is in balance. Since  $L_1$  and  $L_3$  are in separate arms of the bridge, resistance is canceled. This circuit assumes high impedance at  $E_0$  and close matching of resistance between wires  $L_1$  and  $L_3$ . Minco matches RTD leads within 5%.

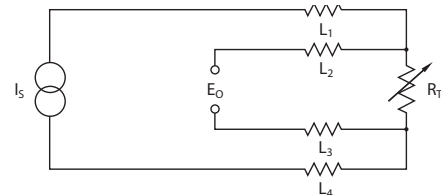

## 4-wire circuit

4-wire RTD circuits not only cancel leadwires but remove the effects of mismatched resistances such as contact points. A common version is the constant current circuit shown above.  $I_s$  drives a precise measuring current through  $L_1$  and  $L_4$ .  $L_2$  and  $L_3$  measure the voltage drop across the RTD element.  $E_0$  must have high impedance to prevent current flow in the potential leads. 4-wire circuits may be usable over longer distances than 3-wire, but you should consider using a transmitter in electrically noisy environments.

If necessary you can connect a 2-wire RTD to a 3-wire circuit or 4-wire circuit, as shown to the right. As long as the junctions are near the RTD, as in a connection head, errors are negligible.

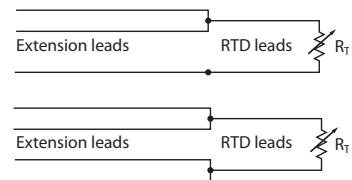

# Resistance/Temperature Tables

Platinum elements												
Element code	PJ	PA	PB	PD, PE*	PN	PL	PH	PP	PG	PF	PW	PS
Resistance at 0°C	25.5 Ω	100 Ω	100 Ω	100 Ω	200 Ω	470 Ω	500 Ω	500 Ω	500 Ω	1000 Ω	1000 Ω	10k Ω
TCR (Ω/Ω/°C)	0.00392	0.00392	0.00391	0.00385	0.00385	0.00392	0.00392	0.00391	0.00385	0.00385	0.00375	0.00385
Sensitivity (Average Ω/°C)	0.1	0.392	0.391	0.385	0.77	1.845	1.963	1.955	1.925	3.85	3.75	38.5
Temperature (°C)	Resistance (ohms)											
-200	4.33	17.00	17.26	18.52	37.04	79.88	84.98	86.30	92.60	185.20		1,852
-180	6.56	25.72	25.97	27.10	54.19	120.88	128.59	129.84	135.48	270.96		2,710
-160	8.75	34.31	34.54	35.54	71.09	161.28	171.57	172.72	177.72	355.43		3,554
-140	10.91	42.80	43.01	43.88	87.75	201.15	213.99	215.03	219.38	438.76		4,388
-120	13.05	51.19	51.37	52.11	104.22	240.57	255.93	256.83	260.55	521.10		5,211
-100	15.17	59.49	59.64	60.26	120.51	279.58	297.43	298.19	301.28	602.56		6,026
-80	17.27	67.71	67.83	68.33	136.65	318.23	338.55	339.17	341.63	683.25		6,833
-60	19.35	75.87	75.96	76.33	152.66	356.57	379.53	379.80	381.64	763.28		7,633
-40	21.41	83.96	84.03	84.27	168.54	394.63	419.82	420.13	421.35	842.71	846.57	8,427
-20	23.46	92.01	92.04	92.16	184.32	432.43	460.03	460.19	460.80	921.60	923.55	9,216
0	25.50	100.00	100.00	100.00	200.00	470.00	500.00	500.00	500.00	1000.00	1000.00	10,000
20	27.53	107.95	107.92	107.79	215.59	507.35	539.73	539.58	538.96	1077.94	1075.96	10,779
40	29.54	115.85	115.78	115.54	231.08	544.47	579.23	578.92	577.70	1155.41	1151.44	11,554
60	31.54	123.70	123.60	123.24	246.48	581.38	618.49	618.02	616.21	1232.42	1226.44	12,324
80	33.53	131.50	131.38	130.90	261.79	618.06	657.51	656.90	654.48	1308.97	1300.96	13,090
100	35.51	139.26	139.11	138.51	277.01	654.53	696.31	695.54	692.53	1385.06	1375.00	13,851
120	37.48	146.97	146.79	146.07	292.14	690.77	734.86	733.94	730.34	1460.68	1448.56	14,607
140	39.43	154.64	154.42	153.58	307.17	726.79	773.18	772.11	767.92	1535.84	1521.63	15,358
160	41.37	162.25	162.01	161.05	322.11	762.59	811.27	810.05	805.27	1610.54	1594.22	16,105
180	43.31	169.82	169.55	168.48	336.96	798.18	849.12	847.75	842.39	1684.78	1666.33	16,848
200	45.22	177.35	177.04	175.86	351.71	833.54	886.74	885.22	879.28	1758.56	1737.96	17,586
220	47.13	184.82	184.49	183.19	366.38	868.68	924.12	922.46	915.94	1831.88	1809.11	18,319
240	49.02	192.25	191.89	190.47	380.95	903.59	961.27	959.46	952.36	1904.73	1879.78	19,047
260	50.91	199.64	199.24	197.71	395.42	938.29	998.18	996.22	988.56	1977.12	1949.96	19,771
280	52.78	206.97	206.55	204.91	409.81	972.77	1034.86	1032.76	1024.52	2049.05	2019.67	20,490
300	54.64	214.26	213.81	212.05	424.10	1007.03	1071.31	1069.06	1060.26	2120.52	2088.89	21,205
320	56.48	221.50	221.02	219.15	438.30	1041.06	1107.51	1105.12	1095.76	2191.52	2157.63	21,915
340	58.32	228.70	228.19	226.21	452.41	1074.88	1143.49	1140.95	1131.03	2262.06	2225.89	22,621
360	60.14	235.85	235.31	233.21	466.43	1108.47	1179.23	1176.55	1166.07	2332.14	2293.67	23,321
380	61.95	242.95	242.38	240.18	480.35	1141.85	1214.73	1211.91	1200.88	2401.76	2360.96	24,018
400	63.75	250.00	249.41	247.09	494.18	1175.00	1250.00	1247.04	1235.46	2470.92	2427.78	24,709
420	65.54	257.01	256.39	253.96	507.92	1207.93	1285.03	1281.94	1269.81	2539.62	2494.11	25,396
440	67.31	263.97	263.32	260.79	521.57	1240.64	1319.83	1316.60	1303.92	2607.85	2559.96	26,078
460	69.07	270.88	270.21	267.56	535.12	1273.14	1354.40	1351.03	1337.81	2674.62	2625.33	26,756
480	70.83	277.75	277.04	274.29	548.59	1305.41	1388.73	1385.22	1371.46	2742.93	2690.22	27,429
500	72.56	284.57	283.84	280.98	561.96	1337.46	1422.83	1419.18	1404.89	2808.78	2754.63	28,098
520	74.29	291.34	290.58	287.62	575.23	1369.28	1456.69	1452.91	1438.08	2876.16		28,762
540	76.01	298.06	297.28	294.21	588.42	1400.89	1490.31	1486.40	1471.04	2942.08		29,421
560	77.71	304.74	303.93	300.75	601.51	1432.28	1523.70	1519.66	1503.77	3007.54		30,075
580	79.40	311.37	310.54	307.25	614.51	1463.45	1556.86	1552.68	1536.27	3072.54		30,725
600	81.08	317.96	317.09	313.71	627.42	1494.39	1589.78	1585.47	1568.54	3137.08		31,371
620	82.75	324.49	323.60	320.12	640.23	1525.12	1622.47	1618.02	1600.58	3201.16		
640	84.40	330.98	330.07	326.48		1555.62	1654.92	1650.35				
660	86.04	337.43	336.49	332.79		1585.91	1687.14	1682.43				
680	87.67	343.82	342.86	339.06		1615.97	1719.12	1714.29				
700	89.29	350.17	349.18	345.28		1645.81	1750.87	1745.91				
720				351.46								
740				357.59								
760				363.67								
780				369.71								
800				375.70								
820				381.65								
840				387.55								
850				390.48								

\* PD is the most common platinum sensor element used by industry. PE has a wider manufacturing tolerance than PD.

Note: More element options and complete tables in 1°C or 1°F increments are available from Minco at [www.minco.com/](http://www.minco.com/)



# Resistance/Temperature Tables

Most RTD tables follow the modified Callendar-Van Dusen equation:

$$R_t = R_0 [1 + At + Bt^2 + Ct^3]$$

or some variation thereof, where  $R_t$  is the modified resistance at temperature  $t$ ,  $R_0$  is the ice point resistance, and  $A$ ,  $B$ , and  $C$  are coefficients describing a given thermometer. Download Minco's white paper entitled *Resistance Thermometry: Principles and Applications of Resistance Thermometers and Thermistors* at [www.minco.com](http://www.minco.com) for a complete set of equations and coefficients for numerical calculation of resistance vs temperature.

	Copper	Nickel	Nickel-iron			Thermistors			
Element code	CA	NA	FA	FB	FC	TA	TB	TF	TK
Base resistance	10 $\Omega$ at 25°C	120 $\Omega$ at 0°C	604 $\Omega$ at 0°C	1000 $\Omega$ at 70°F	2000 $\Omega$ at 70°F	2252 $\Omega$ at 25°C	10k $\Omega$ at 25°C	50k $\Omega$ at 25°C	10k $\Omega$ at 25°C
TCR ( $\Omega / \Omega / ^\circ C$ )	.00427	.00672	.00518	.00527	.00527	$R_{25}/R_{125} = 29.2$	$R_{25}/R_{125} = 23.5$	$R_{25}/R_{125} = 31.2$	$R_{25}/R_{125} = 26.6$
Sensitivity (Average $\Omega / ^\circ C$ )	0.039	0.806	3.133	4.788	9.576	-72	-287	-1523	-324
Temperature ( $^\circ C$ )	Resistance (ohms)								
-100	5.128		372.79						
-80	5.923	66.60	410.73			1660 K	3558 K		
-60	6.712	79.62	452.82			316.5 K	845.9 K		
-40	7.490	92.76	499.06			75.79 K	239.8 K	1380 K	348.9 K
-20	8.263	106.15	549.46	826.90	1653.81	21.87 K	78.91 K	431.8 K	100.2 K
0	9.035	120.00	604.00	908.40	1816.81	7355	29.49 K	155.6 K	33.15 K
20	9.807	134.52	660.97	995.04	1990.09	2814	12.26 K	62.24 K	12.52 K
40	10.580	149.79	720.79	1086.49	2172.99	1200	5592	26.64 K	5323
60	11.352	165.90	783.45	1182.50	2365.01	560.3	2760	12.31 K	2510
80	12.124	182.84	848.97	1282.83	2565.66	282.7	1458	6117	1293
100	12.897	200.64	917.33	1387.21	2774.44	152.8	816.8	3256	718.5
120	13.669	219.29	988.54	1495.42	2990.84	87.7	481.8	1836	425.0
140	14.442	238.85	1062.60	1607.18	3214.37	53.0	297.2		
160	15.217	259.30	1139.50	1722.26	3444.54				
180	15.996	280.77	1219.26	1840.41	3680.84				
200	16.776	303.46	1301.86	1961.38	3922.77				
220	17.555	327.53							
240	18.335	353.14							
260	19.116	380.31							

Note: More element options and complete tables in  $1^\circ C$  or  $1^\circ F$  increments are available from Minco at [www.minco.com](http://www.minco.com)

# Thermocouple Voltage/Temperature Tables

Junction type:	E Chromel-Constantan +  - Purple Red	J Iron-Constantan +  - White Red	K Chromel-Alumel +  - Yellow Red	T Copper-Constantan +  - Blue Red
Sensitivity (mV/ $^\circ C$ ):	0.063	0.053	0.041	0.043
Temperature ( $^\circ C$ )	Millivolts			
-200	-8.824	-7.890	-5.891	-5.603
-150	-7.279	-6.499	-4.912	-4.648
-100	-5.237	-4.632	-3.553	-3.378
-50	-2.787	-2.431	-1.889	-1.819
0	0.000	0.000	0.000	0.000
50	3.047	2.585	2.022	2.035
100	6.317	5.268	4.095	4.277
150	9.787	8.008	6.137	6.702
200	13.419	10.777	8.137	9.286
250	17.178	13.553	10.151	12.011
300	21.033	16.325	12.207	14.860
350	24.961	19.089	14.292	17.816
400	28.943	21.846	16.395	20.869
450	32.960	24.607	18.513	
500	36.999	27.388	20.640	
550	41.045	30.210	22.772	

Note: Complete tables in  $1^\circ C$  or  $1^\circ F$  increments are available from Minco at [www.minco.com](http://www.minco.com)

# Temperature Coefficient of Resistance (TCR)

TCR differentiates RTDs by their resistance/temperature curves. Sometimes called alpha ( $\alpha$ ), it is specified in various ways by different manufacturers.

In this guide TCR is the RTD's resistance change from 0 to 100°C, divided by the resistance at 0°C, divided by 100°C:

$$TCR (\Omega/\Omega/^\circ C) = \frac{R_{100^\circ C} - R_{0^\circ C}}{R_{0^\circ C} \times 100^\circ C}$$

For example, a platinum thermometer measuring 100  $\Omega$  at 0°C and 139.11  $\Omega$  at 100°C has TCR 0.00391  $\Omega/\Omega/^\circ C$ :

$$TCR = \frac{139.11\Omega - 100\Omega}{100\Omega \times 100^\circ C}$$

For a copper RTD, 10  $\Omega$  at 25°C, TCR is:

$$TCR = \frac{12.897\Omega - 9.035\Omega}{9.035\Omega \times 100^\circ C} = 0.00427$$

Stated another way, TCR is the average resistance increase per degree of a hypothetical RTD measuring 1  $\Omega$  at 0°C.

The most common use of TCR is to distinguish between curves for platinum, which is available with TCRs ranging from 0.00375 to 0.003927. The highest TCR indicates the highest purity platinum, and is mandated by ITS-90 for standard platinum thermometers.

There are no technical advantages of one TCR versus another in practical industrial applications. 0.00385 platinum is the most popular worldwide standard and is available in both wire-wound and thin-film elements.

In most cases, all you need to know about TCR is that it must be properly matched when replacing RTDs or connecting them to instruments.

## SensorCalc Program

RTD and thermocouple tables are available online at [www.minco.com](http://www.minco.com)

You can create and store tables in a variety of formats. You can also enter resistances and coefficients for custom tables, using Callendar-Van Dusen or ITS-90 equations.

## Miscellaneous Specifications and Codes

### Thread specifications

Thread	Applicable specifications
G $\frac{1}{2}$	<ul style="list-style-type: none"> <li>ISO 228/1</li> <li>DIN 259</li> <li>BS 2779</li> <li>JIS B0202</li> </ul>
R $\frac{1}{4}$ R $\frac{1}{8}$	<ul style="list-style-type: none"> <li>ISO 7/1</li> <li>DIN 2999</li> <li>BS 21</li> <li>JIS B0203</li> </ul>

### Wire gauge conversion

Wire Gauge Number AWG	Cross Sectional Area mm <sup>2</sup>		Resistance $\Omega$ /ft. at 25°C
	Stranded	Solid	
30	0.057	0.051	0.1058
28	0.089	0.080	0.0666
26	0.141	0.128	0.0418
24	0.227	0.205	0.0262
22	0.355	0.324	0.0165
20	0.563	0.519	0.0103
18	0.897	0.823	0.0065

### Ingress Protection (IP) Codes

	First Number Protection against solid bodies	Second Number Protection against liquid
0	No protection	No protection
1	Objects > 50 mm	Vertically dripping water
2	Objects > 12 mm	75° to 90° dripping water
3	Objects > 2.5 mm	Sprayed water
4	Objects > 1 mm	Splashed water
5	Dust-protected	Water jets
6	Dust-tight	Heavy seas
7		Effects of immersion
8		Indefinite immersion

### Approximate US Enclosure Type Equivalent to IPXX

Type	IP	Type	IP	Type	IP
1	10	3S	54	6 & 6P	67
2	11	4 & 4X	55	12 & 12K	52
3	54	5	52	13	54
3R	14				



# Material Selection Guide

This guide lists the least expensive materials compatible with various corrosive media. The user should also consider unusual temperatures or levels of concentration. Contact Minco Sales and Customer Service for assistance.

Medium	°F (°C)	Material
Acetic acid	212 (100)	Monel
Acetic anhydride	300 (149)	Nickel
Acetone	212 (100)	304 SS
Acetylene	400 (204)	304 SS
Alcohols	212 (100)	304 SS
Alum. (Potassium or sodium)	300 (149)	Hastelloy C
Aluminum chloride	212 (100)	Hastelloy B
Aluminum sulfate	212 (100)	316 SS
Ammonia, dry	212 (100)	316 SS
Ammonium hydroxide	212 (100)	316 SS
Ammonium chloride 50%	300 (149)	Monel
Ammonium nitrate	300 (149)	304 SS
Ammonium sulfate	212 (100)	316 SS
Amyl acetate	300 (149)	304 SS
Aniline	25 (-4)	Monel
Asphalt	250 (121)	304 SS
Atmosphere (industrial and marine)		304 SS
Barium compounds	See calcium	
Beer	70 (21)	304 SS
Benzene	212 (100)	Steel
Benzoic acid	212 (100)	316 SS
Bleaching powder 15%	70 (21)	Monel
Borax	212 (100)	Brass
Bordeaux mixture	200 (93)	304 SS
Boric acid	400 (204)	316 SS
Bromine, dry	125 (52)	Monel
Butane	400 (204)	Steel
Butyric acid	212 (100)	Hastelloy C
Calcium bisulphite	75 (24)	Hastelloy C
Calcium chloride	212 (100)	Hastelloy C
Calcium hydroxide 20%	300 (149)	Hastelloy C
Calcium hypochlorite	See bleaching powder	
Carbolic acid	See phenol	
Carbon dioxide, dry	800	Brass
Carbonated water	212 (100)	304 SS
Carbonated beverages	212 (100)	304 SS
Carbon disulfide	200 (93)	304 SS
Carbon tetrachloride	125 (52)	Monel
Chlorine, dry	100 (38)	Monel
Chlorine, moist	100 (38)	Monel
Chloroacetic acid	212 (100)	Monel
Chloroform, dry	212 (100)	Monel
Chromic acid	300 (149)	Hastelloy C
Cider	300 (149)	304 SS
Citric acid	212 (100)	Hastelloy C
Copper (10) chloride	212 (100)	Hastelloy C
Copper (10) nitrate	300 (149)	316 SS
Copper (10) sulfate	300 (149)	316 SS
Copper plating solution (cyanide)	180 (82)	304 SS
Copper plating solution (acid)	75 (24)	304 SS
Corn oil	200 (93)	304 SS
Creosote	200 (93)	304 SS
Crude oil	300 (149)	Monel
Ethyl acetate	See lacquer thinner	
Ethyl chloride, dry	500 (260)	Steel
Ethylene glycol (uninhibited)	212 (100)	304 SS
Ethylene oxide	75 (24)	Steel
Fatty acids	500 (260)	316 SS
Ferric chloride	75 (24)	Hastelloy C
Ferric sulphate	300 (149)	304 SS
Formaldehyde 40%	212 (100)	316 SS
Formic acid	300 (149)	316 SS
Freon	300 (149)	Steel
Fluorine, anhydrous	100 (38)	304 SS
Furfural	450 (232)	316 SS
Gasoline	300 (149)	Steel
Glucose	300 (149)	304 SS
Glue, pH 6-8	300 (149)	304 SS
Glycerine	212 (100)	Brass
Hydrobromic acid	212 (100)	Hastelloy C
Hydrochloric acid 37-38%	225 (107)	Hastelloy B
Hydrogen chloride, dry	500 (260)	304 SS
Hydrocyanic acid	212 (100)	304 SS

Medium	°F (°C)	Material
Hydrofluoric acid 60%	212 (100)	Monel
Hydrogen fluoride, dry	175 (79)	Steel
Hydrofluogilic acid 40%	212 (100)	Monel
Hydrogen peroxide 10-100%	125 (52)	304 SS
Kerosene	300 (149)	Steel
Lacquers & thinners	300 (149)	304 SS
Lactic acid	300 (149)	316 SS
Lime	212 (100)	316 SS
Linseed oil	75 (24)	Steel
Magnesium chloride 50%	212 (100)	Nickel
Magnesium hydroxide (or oxide)	75 (24)	304 SS
Magnesium sulphate 40%	212 (100)	304 SS
Mercuric chloride 10%	75 (24)	Hastelloy C
Mercury 100%	700 (371)	Steel
Methylene chloride	212 (100)	304 SS
Methyl chloride, dry	75 (24)	Steel
Milk, fresh or sour	180 (82)	304 SS
Molasses	See glucose	
Natural gas	70 (21)	304 SS
Nitric acid	75 (24)	304 SS
Nitric acid	300 (149)	316 SS
Oxygen	75 (24)	Steel
Oleic acid	See fatty acids	
Oxalic acid	212 (100)	Monel
Photographic bleaching	100 (38)	304 SS
Palmitic acid	See fatty acids	
Phosphoric acid	212 (100)	316 SS
Phenol	212 (100)	316 SS
Potassium compounds	See sodium compounds	
Propane	300 (149)	Steel
Rosin 100%	700 (371)	316 SS
Sea water	75 (24)	Monel
Soap & detergents	212 (100)	304 SS
Sodium bicarbonate 20%	212 (100)	316 SS
Sodium bisulphite 20%	212 (100)	304 SS
Sodium bisulphate 20%	212 (100)	304 SS
Sodium carbinatate 40%	212 (100)	316 SS
Sodium chloride 30%	300 (149)	Monel
Sodium chromate	212 (100)	316 SS
Salt or brine	See sodium chloride	
Sodium cyanide	212 (100)	304 SS
Sodium hydroxide 30%	212 (100)	316 SS
Sodium hypochlorite 10%	75 (24)	Hastelloy C
Sodium nitrate 40%	212 (100)	304 SS
Sodium nitrite 20%	75 (24)	316 SS
Sodium phosphate 10%	212 (100)	Steel
Sodium silicate 10%	212 (100)	Steel
Sodium sulfide 30%	212 (100)	316 SS
Sodium sulfite 10%	212 (100)	316 SS
Sodium sulfate 30%	212 (100)	304 SS
Sodium thiosulfate	212 (100)	304 SS
Steam		304 SS
Stearic acid	See fatty acids	
Sugar solution	See glucose	
Sulfur	500 (260)	304 SS
Sulfur chloride, dry	75 (24)	316 SS
Sulfur dioxide, dry	500 (260)	316 SS
Sulfur trioxide, dry	500 (260)	316 SS
Sulfuric acid 10%	212 (100)	316 SS
Sulfuric acid 10-90%	212 (100)	Hastelloy B
Sulfuric acid 90-100%	212 (100)	316 SS
Sulfuric acid, fuming	175 (79)	Hastelloy C
Sulfurous acid 20%	75 (24)	316 SS
Titanium tetrachloride	75 (24)	316 SS
Tannic acid 40%	75 (24)	Hastelloy B
Toluene	75 (24)	Steel
Trichloroacetic acid	75 (24)	Hastelloy B
Trichloroethylene, dry	300 (149)	Monel
Turpentine	75 (24)	316 SS
Varnish	150 (66)	Steel
Zinc chloride	212 (100)	Hastelloy B
Zinc sulfate	212 (100)	316 SS





# ▶ SECTION 12: REFERENCE

Part number index.....12-2 to 12-3  
 Industry specifications.....12-4  
 Global Resources.....12-5



# Part Number Index

<b>Accessories</b>	AC101656 .....5-4	AS801.....1-16	CH302.....3-2	FG213.....3-4	<b>RTDs</b>	S306.....6-2
#6 RTV adhesive.....8-7, 9-7	AC101657 .....5-4	AS802.....1-16, 1-20	CH328.....3-3	FG214.....3-4	S3...replace with S18	S307.....6-2
#8 high temperature cement .....10-3	AC101750.....3-6, 3-7	AS803.....1-16	CH330.....3-3	FG215.....3-4	S4...replace with S15	S308.....6-2
#20 stretch tape .....8-7, 9-7	AC101828.....10-3	AS804.....1-16, 1-20	CH335.....3-2	FG216.....3-4	S11.....replace with S13	S309.....6-2
#21 Polyimide tape .....9-7	AC101926.....3-3	AS806.....1-18	CH339.....3-2	FG310.....3-4	S13.....7-4	S324.....6-2
AC171 .....6-12	AC102026.....8-15	AS807.....1-18	CH342.....3-3	FG313.....3-4	S15.....7-4	S325.....6-2
AC172 .....6-12	AC102074.....8-15	AS808.....1-18	CH343.....3-3	FG314.....3-4	S18.....7-4	S326.....6-2
AC190 .....6-12	AC102551.....8-15	AS809.....1-18	CH356.....3-3	FG537.....3-9	S23.....replace with S7401	S330.....6-2
AC191 .....6-12	AC102647.....8-15	AS810.....1-16, 1-20	CH357.....3-3	FG556.....3-9	S24.....replace with S7401	S331.....6-2
AC192 .....6-12	AC102732.....8-15	AS811.....1-16	CH358.....3-3	FG563.....3-9	S25.....9-2	S332.....6-2
AC195 .....6-12	AC102734.....4-26	AS812.....1-16, 1-20	CH359.....3-2	FG579.....3-9	S32.....9-4	<b>RTDs cont.</b>
AC196 .....6-12	AC102765.4-23, 8-11	AS813.....1-16	CH360.....3-2	FG602.....3-9	S34.....9-5	S340.....6-2
AC197 .....6-12	AC103133.....3-3, 4-22	AS814.....1-16, 1-20	CH366.....3-2	FG709.....3-9	S35.....9-5	S341.....6-2
AC551 .....8-6	AC103168.....8-11	AS815.....1-16	CH405.....3-3	FG714.....3-9	S38.....9-2	S342.....6-2
AC692 .....8-6	AC103253.....8-11	AS816.....1-18	CH407.....3-3	FG801.....3-4	S44.....2-6	S385.....9-4
AC717 .....3-11	AC103316.....8-15	AS817.....1-18	CH102777.....8-15	FG802.....3-4	S51.....2-2	S386.....9-5
AC718 .....3-11	AC103512.....8-11	AS818.....1-18	<b>Controllers</b>	FG810.....3-4	S52.....2-8	S400.....8-18
AC743 .....4-37	AC103513.....8-11	AS819.....1-18	CT15.....4-35, 7-8	FG854.....3-9	S53.....2-2	S401.....8-18
AC744 .....4-37	AC103528.....3-3, 4-22	AS5000.....5-3	CT16A.....4-37	FG911.....3-4	S54.....2-2	S402.....8-18
AC745 .....4-37	AC203350.....2-14, 2-15, 2-16	AS5002.....5-3	CT224.....4-25, 7-8	FG912.....3-4	S56.....2-2	S403.....8-6
AC746 .....4-37	<b>Assemblies</b>	AS5004.....1-2	CT325.....4-29	FG914.....3-4	S57.....2-2	S404.....8-6
AC766 .....8-7	AS700.....1-10, 1-14	AS5005.....1-2	CT335.....4-31	FG1015.....3-12	S59.....2-2	S405.....8-6
AC805 .....4-22	AS701.....1-10	AS5010.....5-3	CT424.....4-27	FG3015.....3-12	S71.....2-10	S406.....8-5
AC807 .....4-22	AS702.....1-10, 1-14	AS5012.....5-3	CT425.....4-40	FG101072.....3-4	S72.....2-10	S407.....8-5
AC887 .....10-3	AS703.....1-10	AS5140.....1-6	CT435.....4-33	FG101078.....3-4	S73.....2-10	S408.....8-5
AC888 .....10-3	AS704.....1-10, 1-14	AS5141.....1-6	<b>Fittings</b>	FG101080.....3-4	S74.....2-10	S409.....8-18
AC889 .....10-3	AS706.....1-12	AS5145.....1-7	FG110-1.....3-4	MFG811.....3-10	S80.....2-10	S410.....8-18
AC915 .....6-12	AS707.....1-12	AS5146.....1-7	FG111.....3-4	MFG812.....3-10	S81.....2-10	S411.....8-18
AC958 .....3-11	AS708.....1-12	AS5160.....1-8	FG112.....3-4	MFG816.....3-10	S151.....2-2	S412.....8-5
AC961 .....3-11	AS709.....1-12	AS5165.....1-9	FG113-1.....3-4	MFG817.....3-10	S153.....2-2	S413.....8-5
AC996 .....4-37	AS720.....1-10, 1-14	AS5191.....1-3	FG114-1.....3-4	MTW1208.....3-10	S154.....2-2	S414.....8-5
AC1001.....4-37	AS721.....1-10	AS5192.....1-3	FG116.....3-4	<b>Humidity</b>	S155.....2-2	S421.....8-4
AC1009.....4-37	AS722.....1-10, 1-14	AS5200.....1-4	FG117.....3-4	AH429.....8-8	S156.....2-2	S422.....8-4
AC1015.....3-12	AS723.....1-10	AS5201.....1-4	FG120.....3-5	AH439.....8-8	S157.....2-2	S423.....8-4
AC1039.....3-3	AS724.....1-10, 1-14	AS5205.....1-5	FG122.....3-5	AH71.....8-10	S159.....2-2	S445.....8-4
AC3015.....3-12	AS725.....1-10	AS5206.....1-5	FG126.....3-5	AH72.....8-10	S200.....10-2	S446.....8-4
AC100324.....3-14	AS726.....1-12	AS5240.....1-22	FG130.....3-5	AH73.....8-10	S201.....10-2	S447.....8-4
AC100375.....2-18	AS727.....1-12	AS5245.....1-22	FG132.....3-5	AH74.....8-12	S202.....10-2	S448.....8-6
AC100427.....3-3	AS728.....1-12	AS5246.....1-22	FG140.....3-5	AH75.....8-12	S203.....10-2	S449.....8-6
AC101122.....3-3	AS729.....1-12	AS100279.....8-16	FG141.....3-5	<b>Indicators</b>	S204.....10-2	S450.....8-5
AC101377.....3-3	AS760.....1-10, 1-14	AS103282.....8-14	FG142.....3-5	TI196.....4-23	S212.....10-2	S451.....8-5
AC100427.....3-3	AS761.....1-10	AS103759.....8-2	FG143.....3-5	TI350.....4-23, 8-15	S214.....10-2	S454.....8-5
AC101248.....2-18	AS762.....1-10, 1-14	<b>Connection Heads</b>	FG144.....3-9	<b>Level</b>	S245.....10-2	S455.....8-5
AC101377.....3-3	AS763.....1-10	CH103.....3-2	FG145.....3-5	LT364.....2-16	S247.....10-2	S456.....8-4
AC101394.....8-15	AS766.....1-12	CH104.....3-2	FG151.....3-5		S249.....10-2	S457.....8-4
AC101540.....8-15	AS767.....1-12	CH106.....3-2	FG180.....3-9		S251.....10-2	S458.....8-18
	AS800.....1-16, 1-20	CH301.....3-2	FG210.....3-4		S304.....6-2	S459.....8-18
					S305.....6-2	S460.....8-18
						S461.....8-18

S462.....8-7	S857.....2-2	S8025.....7-7	S101733.....6-10	TS667.....9-6	TW248.....3-7	WS326S.....3-15
S463.....8-7	S859.....2-2	S9030.....7-6	S101734.....6-10	TS100149.....8-6	TW252.....3-7	WS426S.....3-15
S464.....8-7	S874.....2-6	S9050.....7-6	S101797.....6-10	TS100150.....8-6	TW447.....3-7	WS522T.....3-15
S467.....8-7	S881.....2-2	S9078.....7-6	S101907.....6-2	TS101769.....8-6	TW477.....3-7	WT120G.....3-15
S468.....8-7	S882.....2-8	S9125.....7-6	S101908.....6-2		TW488.....3-6, 8-17	WT120S.....3-15
S470.....8-6	S883.....2-2	S11016.....7-4	S101909.....6-2	<b>Thermocouples</b>	TW1204.....3-7	WT120T.....3-15
S471.....8-6	S884.....2-2	S11636.....6-2	S101910.....6-2	TC40.....9-6	TW1218.....3-7	WT124G.....3-15
S472.....8-6	S886.....2-2	S12414.....6-2	S101911.....6-2	TC171.....2-11	TW1219.....3-8	WT124S.....3-15
S473.....8-6	S887.....2-2	S13282.....6-2	S101912.....6-2	TC173.....2-11	TW1220.....3-8	WT124T.....3-15
S474.....8-6	S889.....2-2	S14320.....6-2	S101913.....6-2	TC311.....6-3	TW1231.....3-7	
S475.....8-4	S912.....2-12	S14405.....6-2	S102404.....6-11	TC312.....6-3	TW1237.....3-7	
S476.....8-17	S913.....2-12	S14455.....6-2	S102405.....6-11	TC333.....6-3		
S477.....8-17	S914.....2-12	S14456.....6-2	S102406.....6-11	TC344.....6-3	<b>Transmitters</b>	
S478.....8-17	S932.....2-13	S15215.....8-4	S102407.....6-11	TC354.....2-2	TT111.....4-2, 8-19	
S479.....8-17	S933.....2-13	S17422.....9-4	S102408.....6-11	TC355.....2-2	TT115.....8-6, 8-19	
S480.....8-17	S942.....2-13	S17624.....9-2	S102409.....6-11	TC356.....2-2	TT176.....	
S482.....8-18	S943.....2-13	S19827.....10-2	S102410.....6-11	TC357.....2-2	....replace with TT518	
S483.....8-6	S944.....2-13	S20080.....8-4	S102617.....6-6	TC358.....2-2	TT190.....	
S484.....8-5	S953.....2-13	S100001.....8-7	S102618.....6-6	TC359.....2-2	....replace with TT519	
S485.....8-18	S1120.....	S1000050.....7-2	S102619.....6-6	TC360.....2-7	TT205.....4-6	
S486.....8-5	....replace with S1220	S1000051.....7-2	S102662.....6-6	TC361.....2-7	TT220.....	
S488.....8-4	S1140.....	S1000052.....7-2	S102737.....6-11	TC2084.....6-3	....replace with TT520	
S489.....8-6	....replace with S1240	S1000053.....7-2	S200050.....7-2	TC2096.....6-3	TT221.....	
S490.....8-17	S1220.....7-4	S1000054.....7-2	S200051.....7-2	TC2162.....6-3	....replace with TT520	
S492.....8-4	S1240.....7-4	S1000057.....8-18	S200052.....7-2	TC2198.....2-9	TT211.....4-2	
S493.....8-4	S1320.....	S1000060.....8-5	S200053.....7-2	TC2303.....6-3	TT246.....4-4	
S551.....2-2	....replace with S1420	S1000061.....8-17	S200054.....7-2	TC2303.....6-3	TT273.....4-12	
S553.....2-2	S1420.....7-4	S1000062.....8-5	S205459.....2-14	TC2520.....6-3	TT274.....4-14	
S554.....2-2	S3238.....8-7, 9-5	S1000063.....8-6	S207595.....6-8	TC2623.....6-3	TT363.....2-15	
S557.....2-2	S4026.....6-2	S1000064.....8-6	S207596.....6-8	TC2698.....6-3	TT508.....4-8	
S559.....2-2	S5020.....5-2	S1000066.....8-6	S207597.....6-8	TC2741.....6-3	TT509.....4-10	
S601.....2-4	S5022.....5-2	S100144.....10-2	S207598.....6-8	TC2837.....6-3	TT511.....4-18	
S602.....2-4	S7304.....6-2	S100147.....8-6		TC102620.....6-6	TT518.....4-8	
S603.....2-4	S7401.....7-4	S100148.....8-6		TC102621.....6-6	TT519.....4-10	
S604.....2-4	S7682.....	S100305.....7-4	<b>Thermistors</b>	TC102622.....6-6	TT520.....4-16	
S614.....2-4	....replace with S7401	S100415.....7-4	TS424.....8-6	TC102663.....6-6	TT521.....4-18	
S623.....2-5	S7746.....6-2	S100721.....9-2	TS425.....8-6	TC207600.....6-8	TT530.....4-16	
S628.....2-5	S7792.....6-2	S100723.....9-2	TS426.....8-6	TC207601.....6-8	TT531.....4-18	
S634.....2-5	S7908.....6-2	S100724.....9-2	TS427.....8-6	TC207602.....6-8		
S639.....2-5	S8009.....	S100725.....9-2	TS428.....8-5	TC207603.....6-8		
S651.....9-2	....replace with S8010	S100820.....9-2	TS429.....8-5		<b>Wire/Cable</b>	
S665.....9-2	S8010.....7-4	S100837.....8-18	TS430.....8-5		WS122B.....3-15	
S667.....9-2	S8011.....	S101162.....10-2	TS431.....8-5	<b>Thermowells</b>	WS122R.....3-15	
S844.....2-6	....replace with S11016	S101163.....10-2	TS436.....8-7	TW201.....3-6	WS122W.....3-15	
S851.....2-2	S8012.....7-4	S101456.....8-6	TS437.....8-7	TW203.....3-6	WS122Y.....3-15	
S852.....2-8	S8013.....	S101503.....10-2	TS438.....8-18	TW204.....3-6	WS126B.....3-15	
S853.....2-2	....replace with S8014	S101608.....8-6	TS439.....8-18	TW222.....3-7	WS126R.....3-15	
S854.....2-2	S8014.....7-4	S101730.....6-10	TS440.....8-18	TW228.....3-7	WS126W.....3-15	
S856.....2-2	S8015.....	S101731.....6-10	TS441.....8-18	TW234.....3-7	WS126Y.....3-15	
	....replace with S8016	S101732.....6-10	TS665.....9-6	TW238.....3-7	WS222R.....3-15	
	S8016.....7-4			TW239.....3-7	WS222W.....3-15	
					WS322S.....3-15	

# Industry Specifications for Sensors

---

## **ISO 9001: 2000 / AS/EN/SJAC9100 (Registrar: TÜV)**

Minco's Quality Assurance system has been audited and certified to this internationally recognized standard.

## **ATEX DIRECTIVE 94/9/EC**

Issued by: European Commission  
Minco has qualified specific models of sensors and accessories used in potentially hazardous areas to these international requirements.

\* Temperature range of individual models may vary.

## **CENELEC**

Issued by: European Committee for Electrotechnical Standardization  
Minco has qualified specific models of sensors and accessories used in potentially hazardous areas to these international requirements.

## **CSA**

Issued by: Canadian Standards Assn.  
CSA Standards are met through recognized testing labs, such as Underwriters Labs, whose testing covers both the U.S. and Canada (see UL).

## **DIN 43760**

Issued by: Deutsches Institut für Normung (Germany)  
Specifies resistance curves and tolerance for nickel RTDs. Platinum curves are now covered under IEC EN60751.

## **FM**

Issued by: Factory Mutual  
Selected temperature sensors and Temptran™ transmitter models are certified compliant to FM specifications and requirements for use in hazardous areas, for the purposes of safety and property loss prevention.

## **IEC EN60751 (IEC 751)**

Issued by: International Electrotechnical Commission  
IEC 751 has the widest international scope of any RTD standard. It calls for platinum RTDs, 100  $\Omega$  at 0°C, TCR 0.00385  $\Omega/\Omega/^\circ\text{C}$ , in one of two tolerance classes:

Class A:  $\pm 0.06\%$  at 0°C.

Class B:  $\pm 0.12\%$  at 0°C.

All Minco RTDs with PD element code meet Class B. Selected models have Class A as an option.

## **JIS C 1604-1989**

Issued by: Japanese Standards Assn.  
Specifies 100  $\Omega$  0.00385 platinum thermometers in accordance with EN60751, but also makes provision for 0.003916 TCR. Minco can supply RTDs to either curve.

## **MIL-T-24388C(SH)**

Issued by: U.S. Naval Sea Systems Command  
RTDs and thermocouples for shipboard use. Included are platinum RTDs with 0.00392 TCR and nickel models with 0.00672 TCR. See Section 7 for bearing embedment RTDs qualified to this specification. Minco does not currently offer probe or thermowell models to MIL-T-24388.

## **NBS (NIST) Monograph 175, based on ITS-90**

Issued by: National Institute of Standards and Technology  
Sets general standards for thermocouples, including millivolt tables, limits of error, and wire color codes. All Minco thermocouples confirm to this specification.

## **SAMA RC21-4-1966**

Issued by: Scientific Apparatus Makers Association  
Specifies various curves for platinum, nickel, and copper RTDs. The platinum curve, available from Minco, has a resistance of 98.129  $\Omega$  at 0°C and TCR of 0.003923. Placing a fixed resistor of 1.871  $\Omega$  in series with this element makes it fit the EN60751 curve.

## **UL**

Issued by: Underwriters Laboratories  
Selected Minco temperature controllers and temperature transmitters are UL-Listed, and/or UL Recognized Components (see product listings for details).

## **Additional Quality system standards**

Minco also has the capability of meeting MIL-Q-9858, MIL-I-45208, FDA-GMP, and 10CFR50 and -21.

# Global Resources

---

Minco has an established infrastructure around the world to support the growing needs of our global customer base. Each Minco regional center provides sales, customer service, engineering and technical expertise to help you specify and manufacture a reliable temperature sensing solution. Our key regional centers include:

## Minco Global Headquarters

7300 Commerce Lane Northeast  
Minneapolis, MN 55432  
Tel 763.571.3121 | Fax 763.571.0927  
Email [custserv@minco.com](mailto:custserv@minco.com)

## Minco Europe

Zone Industrielle  
09310 Aston, France  
Tel (33) 5 61 03 24 01 | Fax (33) 5 61 03 24 09  
Email [custserv.europe@minco.com](mailto:custserv.europe@minco.com)

## Minco Asia Pacific

1 Maritime Square, #12-05B  
HarbourFront Centre, Singapore 099253  
Tel (65) 6635 6738 | Fax (65) 6635 6724  
Email [custserv.ap@minco.com](mailto:custserv.ap@minco.com)

## Minco China

Unit A3, Floor 15, Tower A, Xihuan Plaza  
No.1 Xizhimenwai Street  
Xicheng Dist., Beijing 100044  
People's Republic of China (PRC)  
Tel (86) 10 5830 1506 ext. 852 and 853 | Fax (86) 10 5830 1500  
Email [custserv.china@minco.com](mailto:custserv.china@minco.com)

## Minco Japan

*East Office*  
KSP West Tower 610  
3-2-1 Sakado, Takatsu-ku, Kawasaki-shi  
Kanagawa 213-0012, JAPAN  
Tel (81) 44 712 5061 | Fax (81) 44 712 5062

### *West Office*

Hiranomachi Century Building 4F  
2-5-8 Hiranomachi, Chuo-ku, Osaka-shi,  
Osaka 541-0046, JAPAN  
Tel (81) 6-6121-2462 | Fax: (81) 6-6121-2463  
Email [custserv.japan@minco.com](mailto:custserv.japan@minco.com)

For more information visit: [www.minco.com](http://www.minco.com).





**MINCO**

© Minco 2015 | [minco.com](http://minco.com)